

Operation Manual

3C Series – Rev 2.8 P/N 160929-10

3C Series Programmable AC & DC load



ADAPTIVE Power Systems

Worldwide Supplier of Power Equipment

Copyright © 2018, Adaptive Power Systems, Inc. (APS) • All Rights Reserved • No reproduction without written authorization from APS.

PAGE LEFT INTENTIONALLY LEFT BLANK FOR HARDCOPY VERSIONS OF THIS DOCUMENT



Table of Contents

1	Contact Information.....	8
2	Warranty, Service & Safety.....	9
2.1	Limited Warranty.....	9
2.2	Service and Spare Parts Limited Warranty.....	9
2.3	Safety Information.....	9
2.4	Safety Notices.....	11
3	Product Overview.....	13
3.1	General Description.....	13
3.2	Operating Modes.....	13
3.2.1	Constant Current Mode.....	13
3.2.2	Linear Constant Current Mode (LIN).....	14
3.2.3	Constant Resistance Mode (CR).....	14
3.2.4	Constant Voltage Mode.....	14
3.2.5	Constant Power Mode.....	15
3.3	Load Applications & Test Modes.....	15
3.3.1	CC Mode Applications.....	16
3.3.2	CR Mode Applications.....	17
3.3.3	CV Mode Applications.....	17
3.3.4	Constant Power Mode Battery Evaluation.....	19
3.4	Built in Test Functions.....	20
3.4.1	Short Circuit Testing.....	21
3.4.2	Power Supply OPP Mode Testing.....	22
3.4.3	Power Supply OCP Mode Testing.....	24
3.4.4	Non-Linear Rectifier Modes.....	26
3.4.5	Fuse Test Mode.....	28
3.4.6	Battery Test Functions.....	32
3.4.7	UPS Transfer Time Test.....	40
3.4.8	Inrush Current Mode.....	41
3.4.9	Current SurgeTest.....	43
3.5	Current Read-back.....	46
3.6	External Sync Mode.....	46
3.7	Product Features.....	46
3.8	Accessories Included.....	47
3.8.1	Terminal RVL1-4 Specs.....	47
3.8.2	Terminal RNYBS8-4 Specs.....	48
3.8.3	Terminal PTV1-12 Specs.....	48
4	Technical Specifications.....	49
4.1	Operating Ranges.....	49
4.2	Operating Modes.....	49
4.3	Test Modes.....	51
4.4	Protection Modes.....	53
4.5	Power Factor & Crest Factor Range.....	54
4.6	Metering.....	54
4.7	Other Specifications.....	55
4.8	AC Input, Cooling, Dimensions, Weights.....	56
4.9	Control Interfaces.....	57
4.10	Voltage versus Current Operating Envelope Charts.....	57
4.10.1	Model 3C018-18 V-I Curve.....	57
4.10.2	Model 3C028-18-EV V-I Curve.....	58
4.10.3	Model 3C028-28 V-I Curve.....	59
4.10.4	Model 3C038-28-EV V-I Curve.....	60
4.10.5	Model 3C038-38 V-I Curve.....	61
4.10.6	Model 3C056-56 V-I Curve.....	62
4.10.7	Model 3C075-75 V-I Curve.....	63
4.10.8	Model 3C112-112 V-I Curve.....	64
4.10.9	Model 3C150-112 V-I Curve.....	65
4.10.10	Model 3C188-112 V-I Curve.....	66
4.10.11	Model 3C225-112 V-I Curve.....	67
5	Unpacking and Installation.....	68
5.1	Inspection.....	68
5.2	Ship Kit.....	68

5.3	Check Line Voltage	68
5.4	Input Fuse	69
5.4.1	Fuse Replacement Procedure	69
5.5	Grounding Requirements	70
5.6	Chassis Position	70
5.7	Rack Mounting	70
5.8	Cleaning	70
5.9	Powering Up	70
5.10	In Case of Malfunction	71
5.11	Load Connection	72
5.12	Remote Control Interfaces	73
5.12.1	GPIB Interface	73
5.12.2	USB, LAN or RS232 Interfaces	73
5.13	Analog I/O Connections	74
5.13.1	Analog Terminal Block	74
5.13.2	Load Wire Inductance Considerations	74
6	Front Panel Operation	77
6.1	Introduction	77
6.2	Front Panel Controls Layout	78
6.3	High Brightness LCD Display	79
6.1	Function Keypad Description	82
6.2	WAVE Keypad Description	85
6.3	Test Function Keypad Description	86
6.4	Rotary Knob and ENTRY Keypad Description	87
6.4.1	Synchronization Source Setting	87
6.5	Operating Modes	89
6.6	Test Modes	90
6.7	Measurement Functions	91
6.8	STORE / RECALL Settings	92
6.8.1	Storing Settings	92
6.8.2	Recalling Settings	92
6.9	Sequence Testing	93
6.9.1	Sequence EDIT mode	93
6.9.2	Sequence EDIT Mode Flow Chart	94
6.9.3	Sequence TEST Mode	95
6.9.4	Sequence TEST Mode Flow Chart	96
6.10	Initial Power-on Settings	97
6.10.1	Last Setting Recall	97
6.10.2	Factory Default Initial Settings	97
6.11	Protection Features	103
6.11.1	Over Voltage Protection	103
6.11.2	Over Current Protection	104
6.11.3	Over Power Protection	104
6.11.4	Over Temperature Protection	104
7	Real Panel Connections	105
7.1	Rear Panel Layout	105
7.2	INPUT Terminals	105
7.3	Wire Size	106
7.4	Connecting a UUT	106
7.5	Voltage Sense Input Terminals	107
7.6	Current Output Monitor (I-Monitor)	107
7.6.1	Isolated Output	108
8	Remote Control Programming	109
8.1	Overview	109
8.2	RS232 Set-up	110
8.3	Programming Syntax	111
8.3.1	Parenthesis	111
8.3.2	Terminators	111
8.4	Command Syntax Tables – Short Form	112
8.4.1	Setting Commands	112
8.4.1	Query Commands	113
8.4.2	Limit Command Syntax	114
8.4.3	Stage Commands	114
8.4.4	System Commands	116

8.4.5	Measure Commands	116
8.4.6	Auto Sequence Commands.....	117
8.5	Command Syntax Tables – Complex Form	118
8.5.1	Setting Commands.....	118
8.5.2	Query Commands.....	119
8.5.3	Limit Command Syntax.....	120
8.5.4	State Commands.....	120
8.5.5	System Commands	121
8.5.6	Measure Commands	121
8.6	Remote Control Command Descriptions	123
8.6.1	Setting Command Descriptions.....	124
8.6.2	Limit Command Descriptions	129
8.6.3	State Command Descriptions.....	130
8.6.4	System Command Descriptions	133
8.6.5	Measurement Command Descriptions	134
8.7	Test Mode Commands.....	135
8.7.1	OCP Test Mode Commands	135
8.7.2	OPP Test Mode Commands	135
8.7.3	Short Circuit Test Mode Commands.....	136
8.8	IEEE488.2 Common Commands.....	136
8.8.1	*ESE	136
8.8.2	*ESR?	137
8.8.3	*IDN?	137
8.8.4	*OPC	137
8.8.5	*RST	138
8.8.6	*SRE	138
8.8.7	*STB?	139
9	Master / Slave Mode Configuration	140
9.1	Overview	140
9.2	Parallel (Boost) Mode.....	140
9.3	Multi-Phase Mode.....	140
9.3.1	Wiring diagrams for Three Phase AC Load Configurations	141
9.3.2	Input Configuration Mode Switch Options (Discontinued)	142
9.4	System Bus Connections	143
9.4.1	Connections.....	144
9.4.2	Suggested system bus cables are:.....	144
9.5	Configuring Master / Slave Mode.....	144
9.5.1	Parallel or Boost Mode	144
9.5.2	Three-Phase Modes	145
9.6	Example of Setups for Parallel or Boost mode.....	146
9.7	Example of setups for 3-Phase system.....	147
9.8	Power ON and OFF Sequence.....	148
9.9	Functions not available in M/S Modes	148
10	USB Driver Installation	149
10.1	Overview	149
10.2	Download USB Driver Archive File.....	149
10.3	USB Driver Installation.....	150
11	LAN Driver Installation	152
11.1	Overview	152
11.2	Factory Default IP Address Setting	152
11.3	Download IP Scanner Utility Program File.....	153
11.4	LAN Setup.....	154
11.5	Setting up a NI-VISA Resource Connection	158
12	Calibration	162
12.1	Overview	162
12.2	Calibration Interval	162
12.3	Calibration Coefficients	162
12.4	Calibration Procedures.....	162
13	CE MARK Declaration of Conformity.....	163
14	RoHS Material Content Declaration	164
INDEX		165

Table of Tables

<i>Table 3-1: Included Accessories</i>	47
<i>Table 5-1: 3C Series AC+DC Load Ship Kit Content</i>	68
<i>Table 6-1: Description of Display Readouts</i>	82
<i>Table 6-2: Function Keypad Description</i>	84
<i>Table 6-3: WAVE Keypad Description</i>	85
<i>Table 6-4: Test Function Keypad Description</i>	86
<i>Table 6-5: Internal or External Sync Circuits</i>	88
<i>Table 6-6: Model 3C018-18 Factory Settings</i>	97
<i>Table 6-7: Model 3C028-18-EV Factory Settings</i>	98
<i>Table 6-8: Model 3C028-28 Factory Settings</i>	98
<i>Table 6-9: Model 3C038-28-EV Factory Settings</i>	99
<i>Table 6-10: Model 3C038-38 Factory Settings</i>	99
<i>Table 6-11: Model 3C038-38 Factory Settings</i>	100
<i>Table 6-12: Model 3C075-75 Factory Settings</i>	100
<i>Table 6-13: Model 3C112-112 Factory Settings</i>	101
<i>Table 6-14: Model 3C150-112 Factory Settings</i>	101
<i>Table 6-15: Model 3C188-112 Factory Settings</i>	102
<i>Table 6-16: Model 3C225-112 Factory Settings</i>	102
<i>Table 8-1: RS232 DB9 Pin Assignments</i>	110
<i>Table 8-2: Supported Command Terminators</i>	111
<i>Table 8-3: Remote Control Setting Command Syntax - Short Form</i>	113
<i>Table 8-4: Remote Control Query Command Syntax - Short Form</i>	114
<i>Table 8-5: Remote Control Limit Command Syntax</i>	114
<i>Table 8-6: Stage Command Syntax</i>	115
<i>Table 8-7: System Commands Syntax</i>	116
<i>Table 8-8: Measure Command Syntax</i>	116
<i>Table 8-9: Auto Sequence Command Syntax</i>	117
<i>Table 8-10: Remote Control Setting Command Syntax - Complex Form</i>	119
<i>Table 8-11: Remote Control Query Command Syntax - Complex Form</i>	120
<i>Table 8-12: Remote Control Limit Command Syntax - Complex Form</i>	120
<i>Table 8-13: Stage Command Syntax - Complex Form</i>	121
<i>Table 8-14: System Commands Syntax - Complex Form</i>	121
<i>Table 8-15: Measure Command Syntax - Complex Form</i>	121
<i>Table 8-16: Event Status Enable Register</i>	136
<i>Table 8-17: Status Byte Register</i>	139

Table of Figures

<i>Figure 3-1: 3C Series Available Test Modes Diagram</i>	15
<i>Figure 3-2: CC Mode Applications</i>	16
<i>Figure 3-3: CC LIN Mode Applications</i>	16
<i>Figure 3-4: CR Mode Applications</i>	17
<i>Figure 3-5: CV Mode Applications</i>	18
<i>Figure 3-6: CP Mode Battery Evaluation Applications</i>	19
<i>Figure 3-11: AC Rectifier Test Mode</i>	26
<i>Figure 3-8: Current Protection Device Categories</i>	28
<i>Figure 3-9: : Fuse Test Trip Mode - Normal and Turbo Mode</i>	29
<i>Figure 3-10: Fuse Test Non-trip Mode - Normal and Turbo Mode</i>	30
<i>Figure 3-7: Battery Test Modes 1 ~ 3</i>	32

Figure 4-1: Model 3C018-18 V-I Curve	57
Figure 4-2: Model 3C028-18-EV V-I Curve	58
Figure 4-3: Model 3C028-28 V-I Curve	59
Figure 4-4: Model 3C038-28-EV V-I Curve	60
Figure 4-5: Model 3C038-38 V-I Curve	61
Figure 4-6: Model 3C056-56 V-I Curve	62
Figure 4-7: Model 3C075-75 V-I Curve	63
Figure 4-8: Model 3C112-112 V-I Curve	64
Figure 4-9: Model 3C150-112 V-I Curve	65
Figure 4-10: Model 3C188-112 V-I Curve	66
Figure 4-11: Model 3C225-112 V-I Curve	67
Figure 5-1: AC Input Voltage Label	68
Figure 5-2: AC Line Fuse Holder Location	69
Figure 5-3: 3C Series Chassis Rear Panel – GPIB Option Location	73
Figure 5-4: Analog I/O Connector	74
Figure 5-5: Cable induced input voltage drop	75
Figure 5-6: Unstable condition waveform capture example	76
Figure 5-7: Load Cable Length and Twisted Pairs	76
Figure 6-1: 3C Series Load Front Panel	77
Figure 6-2: Front Panel Display and Controls Call-outs	78
Figure 6-3: Diagram of available Operating Modes	89
Figure 6-4: Diagram of available Test Modes	90
Figure 6-5: Sequence EDIT Mode Operation Flow Chart	94
Figure 6-6: Sequence TEST Mode Operation Flow Chart	96
Figure 7-1: Rear Panel Connector Locations	105
Figure 7-2: Internal and External Voltage Sense Connections	107
Figure 8-1: RS232 Connection to PC and DB9 Pin out	110
Figure 9-1: Parallel Load Connection	140
Figure 9-2: Three Phase Wye Connection	141
Figure 9-3: Three Phase Delta Connection	141
Figure 9-4: Three Phase AC Load Cabinet with MODE4 Switch Option	142
Figure 9-5: Three Phase AC Load Cabinet Rear View	143
Figure 9-6: Parallel / Boost CC Mode Setup	146
Figure 9-7: Parallel / Boost LIN Mode Setup	146
Figure 9-8: 3-PHS CC Settings	147
Figure 9-9: 3-PHS LIN Settings	147
Figure 9-10: 3-PHS CR Settings	147
Figure 9-11: 3-PHS CP Settings	148
Figure 9-12: 3-PHS CV Settings	148
Figure 10-1: USB Device Driver Download	149
Figure 11-1: LAN IP Scanner Utility Program Download	153

1 Contact Information

AMERICA / CANADA

Adaptive Power Systems, Inc.
Irvine, USA
Phone: +1(949) 752-8400
Fax: +1 (949) 756-0838
Email: support@adaptivepower.com

EUROPE

Caltest Instruments GmbH.
Kappelrodeck, Germany
Phone: +49(0)7842-99722-00
Fax: +49(0)7842-99722-29
Email: support@adaptivepower.com

CHINA

PPST Shanghai Co. Ltd.
Shanghai, China
Phone: +86-21-6763-9223
Fax: +86-21-5763-8240
Email: support@adaptivepower.com

Web: <http://www.adaptivepower.com>

2 Warranty, Service & Safety

2.1 Limited Warranty

Adaptive Power Systems, Inc. (APS) warrants each unit to be free from defects in material and workmanship. For the period of one (1) year from the date of shipment to the purchaser, APS will either repair or replace, at its sole discretion, any unit returned to the APS factory in Irvine, California or one of its designated service facilities. It does not cover damage arising from misuse of the unit or attempted field modifications or repairs. This warranty specifically excludes damage to other equipment connected to this unit.

Upon notice from the purchaser within (30) days of shipment of units found to be defective in material or workmanship, APS will pay all shipping charges for the repair or replacement. If notice is received more than thirty (30) days from shipment, all shipping charges shall be paid by the purchaser. Units returned on debit memos will not be accepted and will be returned without repair.

This warranty is exclusive of all other warranties, expressed or implied.

2.2 Service and Spare Parts Limited Warranty

APS warrants repair work to be free from defects in material and workmanship for the period of ninety (90) days from the invoice date. This Service and Spare Parts Limited Warranty applies to replacement parts or to subassemblies only. All shipping and packaging charges are the sole responsibility of the buyer. APS will not accept debit memos for returned power sources or for subassemblies. Debit memos will cause return of power sources or assemblies without repair.

This warranty is exclusive of all other warranties, expressed or implied.

2.3 Safety Information

This chapter contains important information you should read BEFORE attempting to install and power-up APS Equipment. The information in this chapter is provided for use by experienced operators. Experienced operators understand the necessity of becoming familiar with, and then observing, life-critical safety and installation issues. Topics in this chapter include:

- Safety Notices
- Warnings
- Cautions
- Preparation for Installation
- Installation Instructions



Make sure to familiarize yourself with the **SAFETY SYMBOLS** shown on the next page. These symbols are used throughout this manual and relate to important safety information and issues affecting the end user or operator.

SAFETY SYMBOLS



Direct current (DC)



Alternating current (AC)



Both direct and alternating current



Three-phase alternating current



Protective Earth (ground) terminal



On (Supply)



Off (Supply)

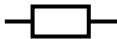

Fuse



Caution: Refer to this manual before this Product.



Caution, risk of electric shock

2.4 Safety Notices

SAFETY SUMMARY

The following general safety precautions must be observed during all phases of operation, service, and repair of this instrument. Failure to comply with these precautions or with specific warnings elsewhere in this manual violates safety standards of design, manufacture, and intended use of the instrument. Adaptive Power Systems assumes no liability for the customer's failure to comply with these requirements.

GENERAL

This product is a Safety Class 1 instrument (provided with a protective earth terminal). The protective features of this product may be impaired if it is used in a manner not specified in the operation instructions.

ENVIRONMENTAL CONDITIONS

This instrument is intended for indoor use in an installation category I, pollution degree 2 environments. It is designed to operate at a maximum relative humidity of 80% and at altitudes of up to 2000 meters. Refer to the specifications tables for the ac mains voltage requirements and ambient operating temperature range.

BEFORE APPLYING POWER

Verify that the product is set to match the available line voltage and the correct fuse is installed.

GROUND THE INSTRUMENT

This product is a Safety Class 1 instrument (provided with a protective earth terminal). To minimize shock hazard, the instrument chassis and cabinet must be connected to an electrical ground. The instrument must be connected to the AC power supply mains through a properly rated three-conductor power cable, with the third wire firmly connected to an electrical ground (safety ground) at the power outlet. Any interruption of the protective (grounding) conductor or disconnection of the protective earth terminal will cause a potential shock hazard that could result in personal injury.

FUSES

Only fuses with the required rated current, voltage, and specified type (normal blow, time delay, etc.) should be used. Do not use repaired Fuses or short circuit the fuse holder. To do so could cause a shock or fire hazard.

DO NOT OPERATE IN AN EXPLOSIVE ATMOSPHERE.

Do not operate the instrument in the presence of flammable gases or fumes.

KEEP AWAY FROM LIVE CIRCUITS.

Operating personnel must not remove instrument covers. Component replacement and internal adjustments must be made by qualified service personnel. Do not replace components with power cable connected. Under certain conditions, dangerous voltages may exist even with the power cable removed. To avoid injuries, always disconnect power, discharge circuits and remove external voltage sources before touching components.

DO NOT SERVICE OR ADJUST ALONE.

Do not attempt internal service or adjustment unless another person, capable of rendering first aid and resuscitation, is present.

DO NOT EXCEED INPUT RATINGS.

This instrument may be equipped with a line filter to reduce electromagnetic interference and must be connected to a properly grounded receptacle to minimize electric shock hazard. Operation at line voltages or frequencies in excess of those stated on the data plate may cause leakage currents in excess of 5.0 mA peak.

DO NOT EXCEED LOAD INPUT VOLTAGE RATING.

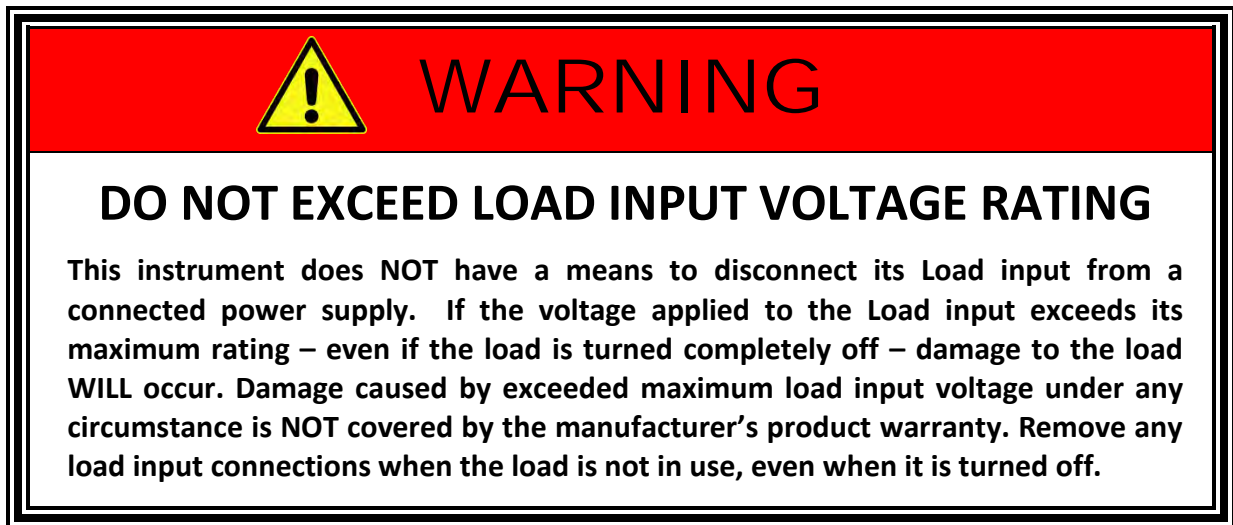

DO NOT SUBSTITUTE PARTS OR MODIFY INSTRUMENT.

Because of the danger of introducing additional hazards, do not install substitute parts or perform any unauthorized modification to the instrument. Return the instrument to an Adaptive Power Systems Sales and Service Office for service and repair to ensure that safety features are maintained.

Instruments that appear damaged or defective should be made inoperative and secured against unintended operation until they can be repaired by qualified service personnel.

3 Product Overview

This chapter provides an overview of the APS 3C Series programmable AC & DC loads. It introduces the reader to general operating characteristics of these loads.

3.1 General Description

The APS 3C Series electronic load is designed to test, evaluation and burn-in of AC or DC power supplies and batteries. The APS 3C Series electronic load can be operated from the front panel (manual mode) or using remote control via one of its optional digital interfaces.

The VI curve constant power contours of the various 3C Series models are shown in the Technical Specification Section. Maximum current and power capability depends on the specific model.

3.2 Operating Modes

Available operating modes for all models are:

- Constant Current (CC) mode
- Linear Constant Current (LIN) mode
- Constant Resistance (CR) mode
- Constant Voltage mode
- Constant Power mode
- UPS Efficiency mode
- PV System Efficiency mode
- UPS Backup Test mode
- Fuse Test mode

A more detailed explanation of each mode and under what condition each mode is most appropriate to use follows.

3.2.1 Constant Current Mode

This is the most commonly used mode of operating when testing a voltage source such as an AC power source, DC supply or battery. In this mode of operation, the load will sink a constant level of current as set by the user, regardless of any voltage variations. A real time feedback loop ensures a stable current under any voltage variation of the AC source, DC supply or battery.

This mode is recommended for load regulation testing, loop stability testing, battery discharge testing and any other form of voltage regulation loop testing.

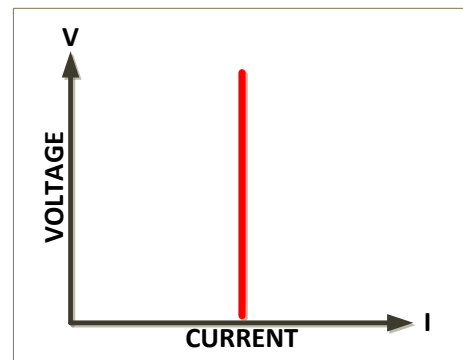

3.2.2 Linear Constant Current Mode (LIN)

When operating in linear constant current mode, the load current input into the 3C Series load depends on the current setting regardless of the input voltage, e.g., the current rms level remains unchanged. The load current will follow the input voltage waveform in real-time.

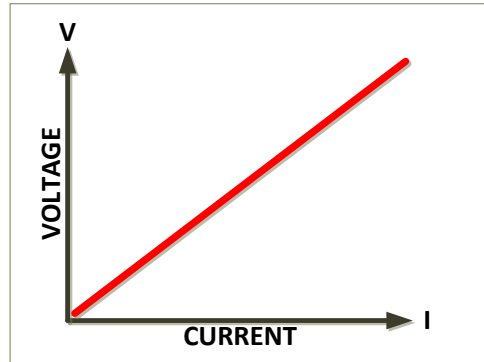

The LIN mode is implemented through a high-bandwidth auto gain control circuit (ACG) and the ACG output current control signal will track the input voltage. The ACG circuit produces a constant amplitude output signal so long as the amplitude of the input signal exceeds an adjustable reference voltage applied to the peak detector. The reference voltage may be changed to change the range of input voltage resulting in a constant-amplitude output.

The ACG circuit responds almost instantly to adjust for a sudden increase in input voltage. This fast voltage transient response makes the LIN mode especially suitable for non-sinusoidal AC voltage inputs such as step waveform, square waveform and any AC input voltage with a highly distorted waveform.

3.2.3 Constant Resistance Mode (CR)

In Constant Resistance mode, the load will sink current directly proportional to the sensed input voltage. The ratio between voltage and current is linear per ohms law and can be set by the user within the operating range of the AC & DC load. The current is defined by the formula shown here where R is the set value in CR mode and V is the AC or DC input voltage from the unit under test.

$$I = V/R$$

CR mode is useful for battery discharge testing of battery systems used to power constant impedance loads as the voltage will decrease as the battery discharges over time resulting in reduced current sinking.

3.2.4 Constant Voltage Mode

In Constant Voltage mode, the load will attempt to sink as much current as needed to reach the programmed voltage setting. This mode should only be used with current controlled DC power sources.

Note: Most power supplies and sources are voltage controlled, i.e. they regulate the output voltage to a predefined voltage level. Such voltage supplies should not be tested using CV mode as the supply voltage regulation loop will conflict with the load control loop.

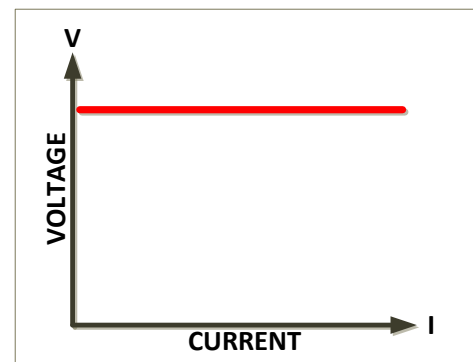

3.2.5 Constant Power Mode

In Constant Power mode, the load will attempt to maintain the programmed Power dissipation by sinking more or less current at the voltage sensed. The current is defined by the formula shown below.

$$I = P/V$$

Constant power mode is useful for battery discharge testing as it simulates constant power drain on the battery, regardless of battery charge state.

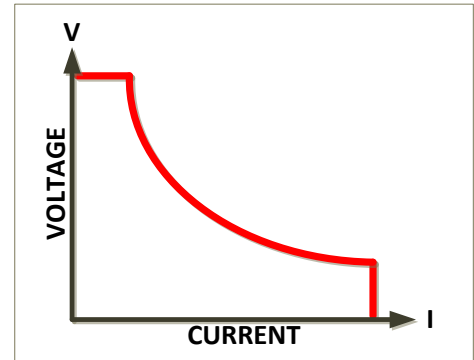

3.3 Load Applications & Test Modes

This section covers various load applications and special test modes that are available on the 3C Series AC+DC Loads. The figure below shows the various test modes for either AC and/or DC applications.

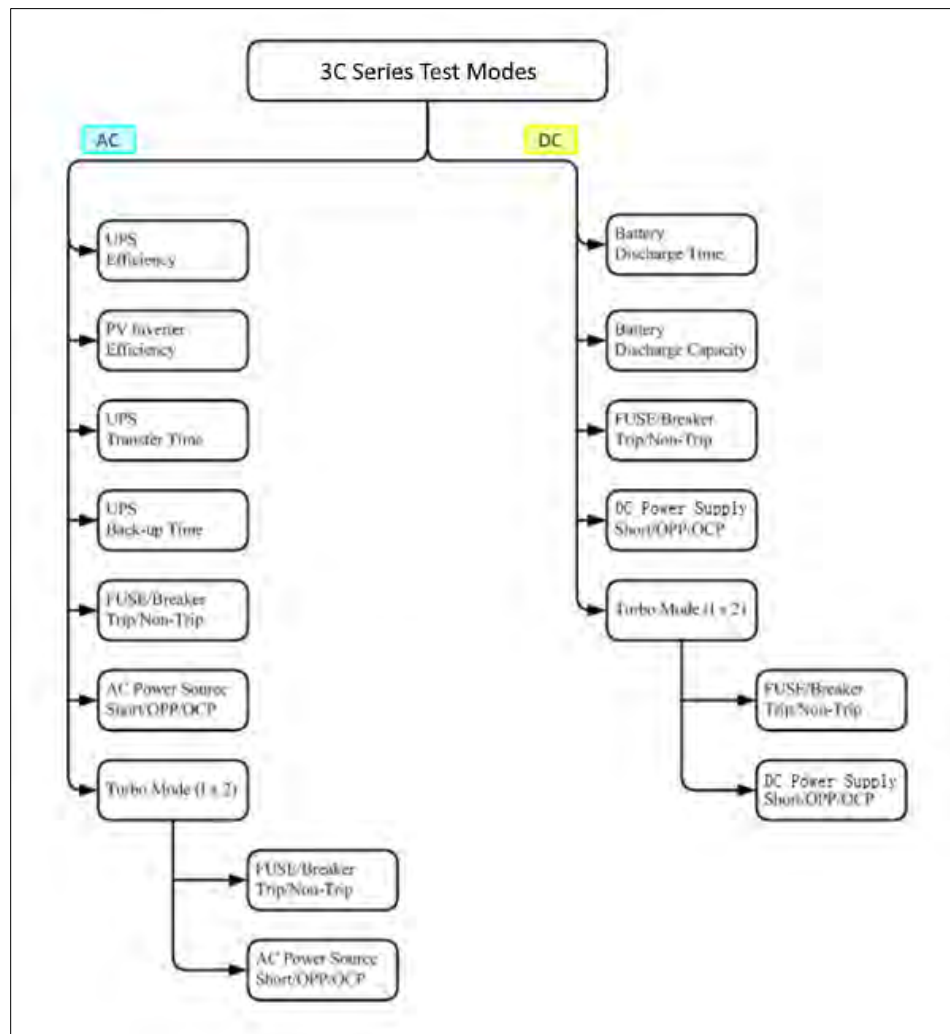

Figure 3-1: 3C Series Available Test Modes Diagram

3.3.1 CC Mode Applications

The Constant Current (CC) mode is ideal for testing the Load Regulation, Cross Regulation, Output Voltage and Dynamic Regulation of a voltage power supply. The CC mode can also be used to test the Discharge Characteristics and the Life Cycle of cells and battery packs. In CC mode, the load can operate as a static load with switchable high and low current levels. It is also possible to operate the load dynamically enabling the user to adjust sink current with time.

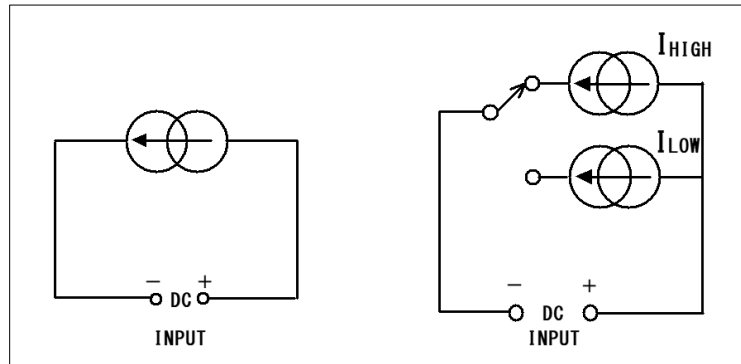

Figure 3-2: CC Mode Applications

Linear CC Mode (LIN)

During Linear C.C. mode, the load current input into the load depends on the current setting regardless of the input voltage, e.g., the current setting remains unchanged. The load input current waveform follows the input voltage waveform.

The LIN mode uses an Automatic Gain Control (AGC) circuit. The circuit will response to the input voltage. The AGC circuit produces a constant amplitude output signal as long as the amplitude of the input voltage exceeds an adjustable reference voltage applied to the peak detector. The reference voltage may be changed to change the range of input voltage resulting in a constant-amplitude output. The AGC circuit responds almost instantly to changes a sudden increase in input voltage.

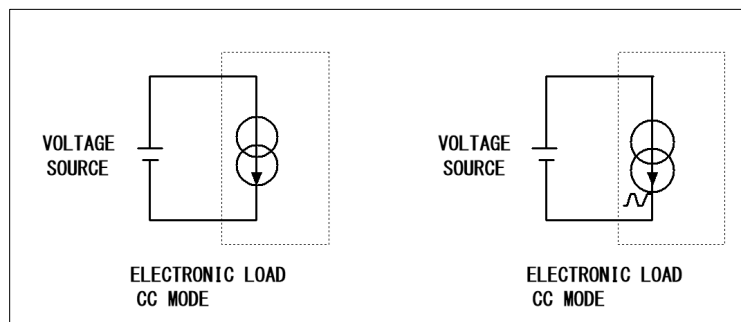

Figure 3-3: CC LIN Mode Applications

The AGC circuit is especially suitable for Step waveform, Square waveform and the AC input voltage sinewaves with high levels of distortion. Examples are DC/AC inverters and UPS's.

3.3.2 CR Mode Applications

Operating in Constant Resistance mode is useful for testing both voltage and current sources. The CR mode is particularly suited for evaluation the ‘soft start’ behavior of power supplies. This is explained in more detail below.

Power Supply Start-up Sequence Tests

With the load set to constant current mode, the current demand at initial ‘Load ON’ of the preset current value is almost instantaneous. This might cause problems for the Device under Test (DUT) if it is unable to satisfy this relatively high current demand at initial switch-on.

For example, a 5V/50A output power supply may not be able to deliver 50A over its entire start-up range of 0-5 volts. In many cases the power supply’s short circuit or over current protection circuit will cause the power supply to shut down under this scenario. This is because the power supply is trying to deliver the 50A at a voltage level that is too low.

The answer to this problem is not to use CC mode but to use CR mode instead. This is because in CR mode the current and voltage ramp up together providing a ‘soft start’ when compared to standard CC mode.

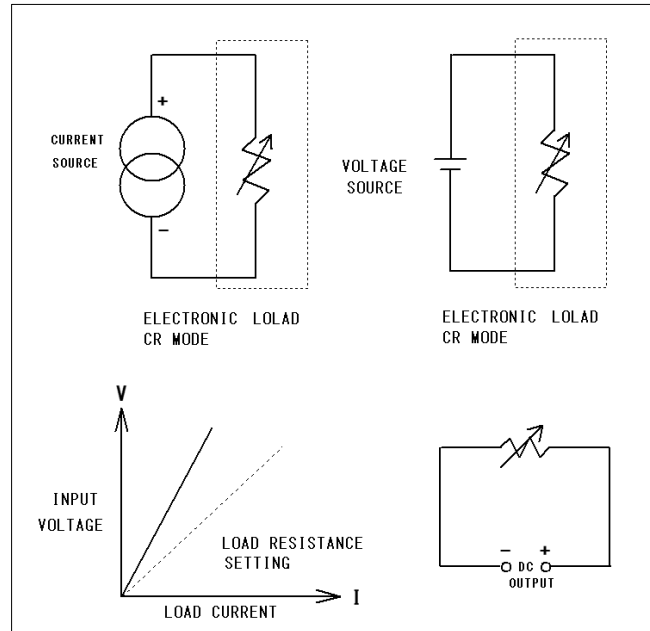

Figure 3-4: CR Mode Applications

Note also that the load allows an adjustable current ramp. This feature is found under dynamic settings as RISE slew rate. Even in static mode the series load will regulate its current demand at ‘Load ON’ in line with the adjusted RISE slew rate. The FALL slew rate also in the dynamic settings allows the current ramp down to be controlled at ‘Load OFF’.

3.3.3 CV Mode Applications

In Constant Voltage (CV) operation, the load will attempt to sink as much current as required in order to reach the set voltage value. CV operation is useful in checking the load regulation of dc current sources. The CV mode is also ideal for characterizing the current limit of dc power supplies.

Current source testing.

A common application for a dc current source is as a battery charger. Most battery chargers are designed to automatically adjust their charging current according to the battery voltage. In CV mode, the electronic load will sink the current that is needed to reach the desired voltage. The CV mode is therefore ideal for checking the charge current at a particular voltage level.

If the battery charger is tested at a number of different voltage levels in CV mode, a current curve can be recorded. Thus, the battery charger’s load regulation can be checked during development and production testing.

Power supply current limit characterization

The current limit function is a necessary feature for all power supplies. A fold back current limit curve is very common for fixed output switching power supplies. A constant current limit curve is more popular for adjustable laboratory power supplies.

It is very difficult or near impossible to find the current limit curve by using CC or CR mode. However, it becomes simple by using CV mode. The user sets the CV voltage and records the output current. Plotting the current measurements against the voltage settings results in the output current limit curve of a power supply.

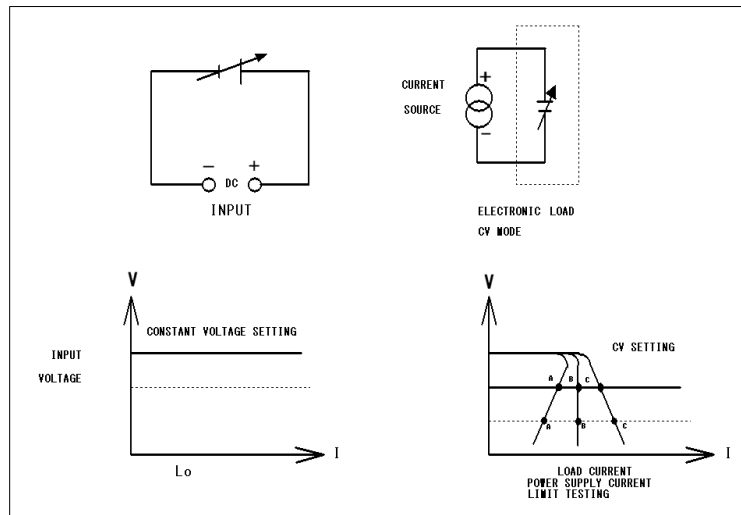

Figure 3-5: CV Mode Applications

3.3.4 Constant Power Mode Battery Evaluation

Primary or secondary batteries are the power source for a wide range of portable electronics products, such as notebook computers, video cameras and mobile phones. To ensure long usage times and customer satisfaction, the battery pack should be able to provide a constant power for the longest time possible.

This can be measured, as the output voltage of a battery will drop over time. The rate of voltage decay depends on a number of factors including duty cycle, chemistry type, battery age and ambient temperature.

So to keep the device powered for the longest possible time the battery must be able to provide a stable power output regardless of output voltage. In order to maintain a constant power the output current will need to increase over time to compensate for the reducing voltage.

Operating the 3C Series electronic load in CP mode is ideal for testing the characteristics of a battery. This is because as the battery voltage drops the load current will automatically increase in order to keep the CP setting. By logging sink values against time the test engineer can also measure the battery's energy capacity at various discharge rates.

The 3C Series load also features an adjustable Load OFF setting. This allows a voltage level to be set so that the electronic load automatically stops sinking power upon reaching this preset voltage. This function can be used to ensure the battery is not subjected to a damaging deep cycle discharge.

Along with static operation, the load can also be operated dynamically in CP mode. The dynamic functions allow the ramp, fall and plateau times to be adjusted between two levels of power. This capability means that 'real world' loads can be more accurately simulated. For example, the dynamic mode could be used to test the performance of a battery that is required to provide power pulses to transmit data from a radio frequency terminal.

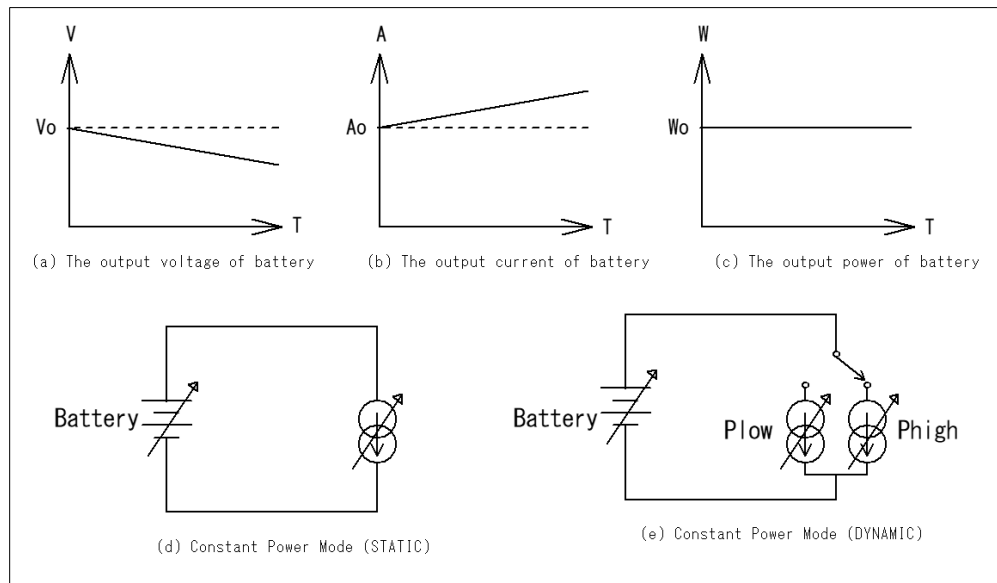
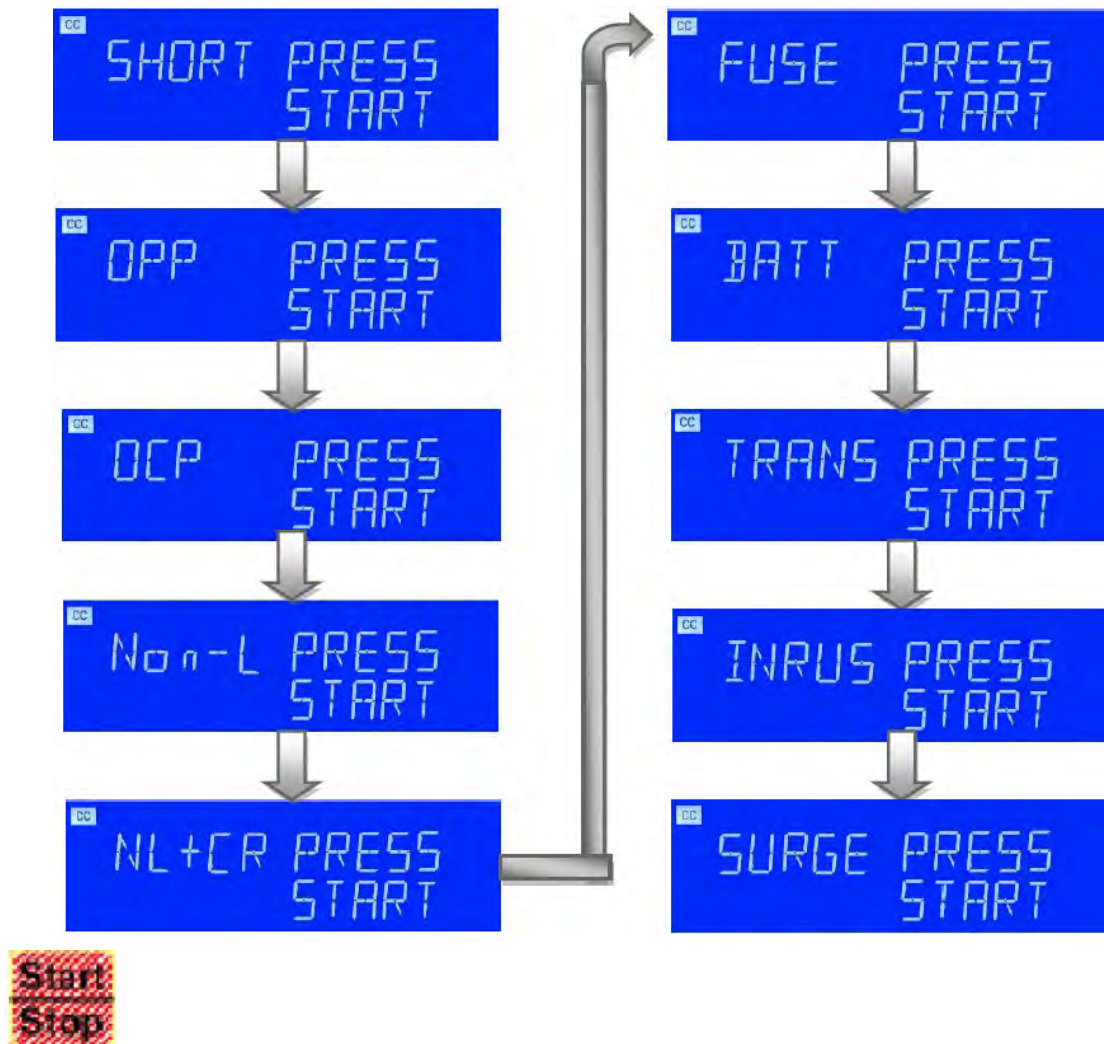

Figure 3-6: CP Mode Battery Evaluation Applications

3.4 Built in Test Functions

Built in test functions can be operated from the front panel. These functions are accessed using the ITEM key. There are eight operating modes, accessible in the following order:

- SHORT
- OPP
- OCP
- Non-L
- NL+CR
- FUSE
- BATT
- TRANS
- INRUSH
- SURGE



The red START/STOP key is used in conjunction with the SHORT, OCP, OPP, Non-L, NL+CR, FUSE, BATT, TRANS test functions. It is used to START a test according to the set parameters or to

STOP a test before PASS or FAIL is signaled. Please refer to the preceding sections for more information on the SHORT, OCP, OPP, Non-L, NL+CR, FUSE, BATT, TRANS INRUS, SURGE tests.

Each test function operation is described in the following sections.

3.4.1 Short Circuit Testing

The Short Circuit test mode tests an EUT for immunity against short circuit conditions that can occur when a circuit powered by a supply experiences a catastrophic failure. The intent is to make sure that the AC or DC power supply shuts down properly without being damaged itself. The 3C Series load does this by applying a preset current level for a programmed period.

The following example shows the Short Circuit test procedure steps. The actual current level and time duration settings will be a function of the ratings of the EUT being tested.

1. Select the Short Circuit test mode by pressing the SHORT key.
2. Press the UP key and set the SHORT TIME to 10,000ms (10 seconds).
3. Press the DOWN key and the V-Hi voltage to 006.00V and press the SHORT key to proceed to the next set point
4. Press the DOWN key and the V-Hi voltage to 000.00V and press the SHORT key to proceed to the next set point
5. When ready to start the test, press the START/STOP key.



If during the Short Circuit test, the UUT's output voltage is between the programmed upper and lower voltage limits, the right upper 5-digit LCD display will show "PASS".



If the power supplies output voltage does not sag between these limits, it will show "FAIL".



3.4.2 Power Supply OPP Mode Testing

OPP test mode is used to test the over power protection (OPP) functions of AC or DC power supplies. OPP functions protect a power supply from damage caused by excessive power load conditions. The 3C Series load allows the power drawn from the power supply under test to be stepped gradually until test units OPP function kicks in.

The following example shows the test procedure steps. The actual power level settings will be a function of the ratings of the EUT being tested, in this case a 5V, 100W supply.

1. Press the **LIMIT** Key function to and set W_Hi to 0030.0W



2. Press the **LIMIT** Key function to and set W_Lo to 0000.0W



3. Select OPP test by pressing the OPP key.



4. Set the start power to 0000.0W and press the OPP key to proceed to the next set point



5. Set the load step power to 0005.0W and press the OPP key to proceed to the next set point



6. Set the stop power to 0100.0W and press the OPP key to proceed to the next set point



7. Set the VTH voltage (Vth setting) to 005.00V and press the OPP key to proceed to the next set point



8. When ready to start the test, press the START/STOP key.

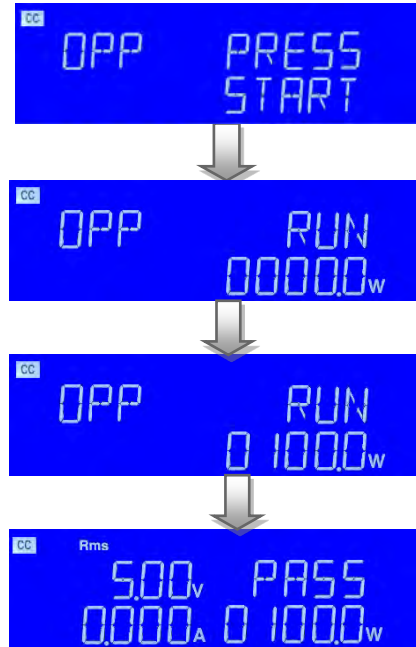

If during the test the UUT's output voltage dropout is lower than the programmed threshold voltage (Vth setting) and the OPP power trip point is between the W_Hi and W_Lo limits, the right upper 5-digit LCD display will show "PASS". If not, it will show "FAIL".



3.4.3 Power Supply OCP Mode Testing

OCP test mode is used to test the over current protection (OCP) functions of AC or DC power supplies. OCP functions protect a power supply from damage caused by excessive current load conditions. The 3C Series load allows the current drawn from the power supply under test to be stepped gradually until test units OCP function kicks in.

The following example shows the test procedure steps. The actual current level settings will be a function of the ratings of the EUT being tested, in this case a 5V, 5A supply.

1. Press the **LIMIT** Key function to and set I_Hi to 08.000A



2. Press the **LIMIT** Key function to and set I_Lo to 00.000A



3. Select OCP test by pressing the OCP key.



4. Set the start current to 00.000A and press the OCP key to proceed to the next set point



5. Set the load step current to 00.100A and press the OCP key to proceed to the next set point



6. Set the stop current to 05.000A and press the OCP key to proceed to the next set point



7. Set the VTH voltage (Vth setting) to 005.00V and press the OCP key to proceed to the next set point



8. When ready to start the test, press the START/STOP key.



If during the test, the UUT's output voltage dropout is lower than the programmed threshold voltage (Vth setting) and the OCP current trip point is between the I_Hi and I_Lo limits, the right upper 5-digit LCD display will show "PASS". If not, it will show "FAIL".



3.4.4 Non-Linear Rectifier Modes

The AC rectified load mode is fully compliant with the IEC 62040-3 test specification requirements for UPS:

- IEC 62040-3 UPS Efficiency Measurement Non-linear
- IEC 61683 Resistive Plus Non-Linear,

The AC rectifier load mode uses CC + CR mode to maintain the current THD at 80%. This simulates an actual device which is connecting the UPS.

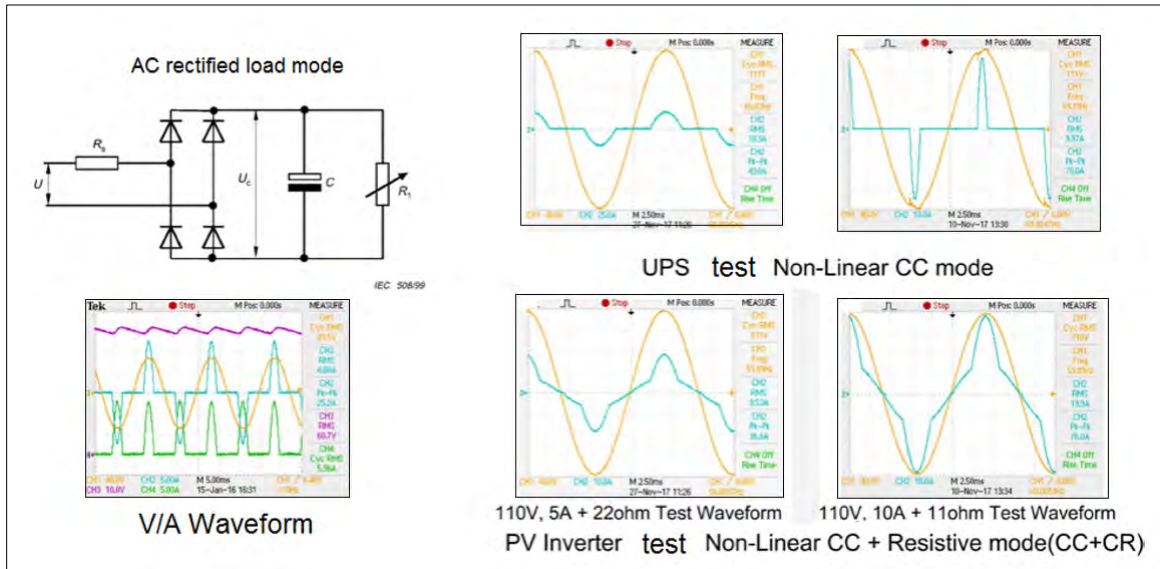

Figure 3-7: AC Rectifier Test Mode

There are two available non-linear test modes:

- Non-L
- NL+CR.

Non-L Nonlinear test key function parameter setting:

Pressing the Item key once will cause the button to illuminate. The message “Non-L PRESS START” will be shown across the displays.

Each press of the setting button moves the menu on one step. The Left and right LCDs show the currently selected test parameter as text. The value is adjusted by the rotary knob and can be read from the Right display during Setting.

The setting sequence is shown below:

- Non-L PRESS START ->
- Non-L CC ->
- Non-L PF ->

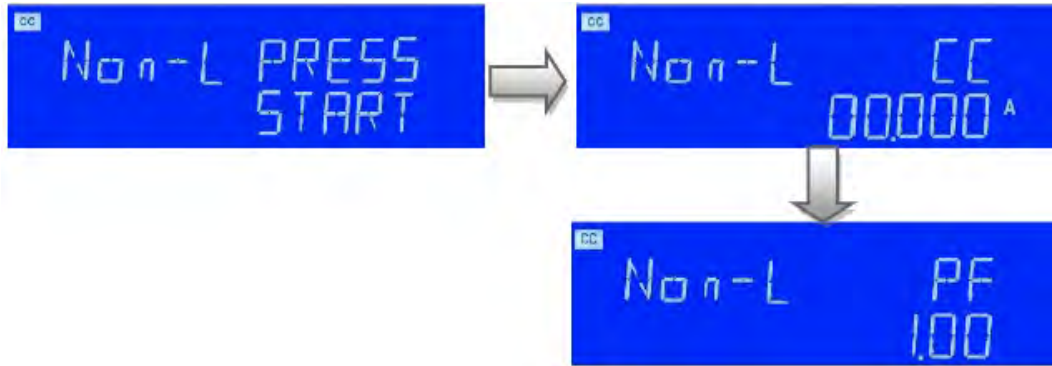

Non-L CC: set the Non-L current point, the Left 5 digit monitor displays “Non-L” ,the right upper 5 digit monitor displays “CC” and the right lower monitor displays the set value in "A". The range is 0.001A to the full scale of the CC mode specification.

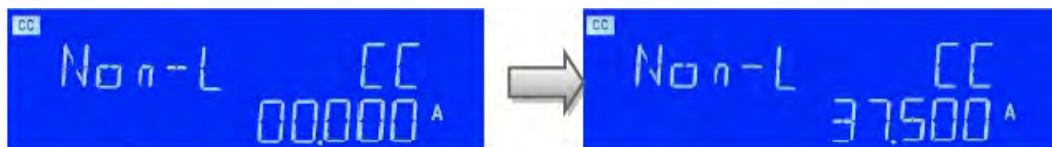

Non-L PF: set the PF, the Left 5 digit monitor displays “Non-L” ,the right upper 5 digit monitor displays “PF” and the right lower monitor displays the set value. The range is 0.01 ~ 1.00.

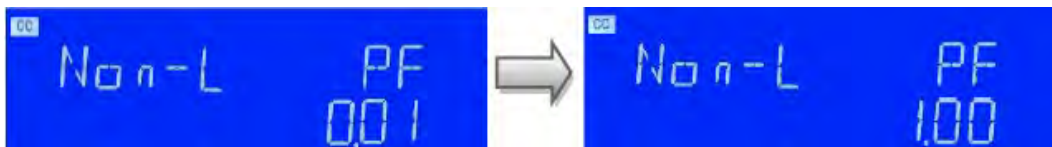

NL+CR Nonlinear plus CR test key function parameter setting:

Pressing the Item key once will cause the button to illuminate. The message “NL+CR PRESS START” will be shown across the displays. Each press of the setting button moves the menu on one step. The Left and right LCDs show the currently selected test parameter as text. The value is adjusted by The rotary knob and can be read from the Right display during Setting.

The setting sequence is shown below:

- NL+CR PRESS START ->
- NL+CR CC ->
- NL+CR CR ->



NL+CR CC: set the NL+CR CC current point. The Left 5 digit monitor displays “NL+CR”, the right upper 5 digit monitor displays “CC” and the right lower monitor displays the set value in “A”. Use the knob and button to set the Nonlinear CC current value, the range is from 0.000A to full scale current of the CC mode specification.



NL+CR CR: setting the NL+CR CR resistance point, the Left 5 digit monitor display the “NL+CR”, the right upper 5 digit monitor display the “CR” and the right lower monitor displays the set value in “Ω”. Use the knob and button to set the CR value from 1.6000Ω to the full scale of the CR mode specification.

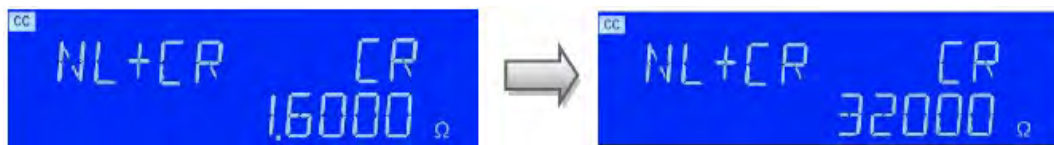

3.4.5 Fuse Test Mode

Current protection components include Fuses, Circuit breakers and PTC Resettable Fuses etc. Their purpose is to open the circuit when the current through the device exceeds the rated design value. If the load current exceeds the design’s current capacity, the circuit will be open and break the current. The purpose is to avoid overheating, damage or worst case a fire.

If an abnormal situation occurs, the protective device must be able to provide circuit break protection capability. As long as the current is within the normal current range, it must continue to support the current.

Examples of types of Current Protection devices are shown in the figure below.



Figure 3-8: Current Protection Device Categories

The current protection component usually has a product relationship of current and time, that is, the greater the current through the current protection component, the shorter the reaction time to protect the circuit.

The 3C Series AC & DC electronic load provides a special Fuse Test function for the verification of current protection components. The Fuse Test function can test and verify protection devices using the rated current and power of the device under test.

The Fuse test has mode provides setting for:

Trip Mode either Trip (fuse) and Non-Trip (no fuse), Test Current I (IStart), Test Time (Time), Test Repeat Number and Repeat Time.

To properly test protection devices, the test current must be higher than the rated current of the device. The TURBO mode can be used to test at higher current levels than would normally be supported by the load. This would otherwise require an electronic load rated twice as high.

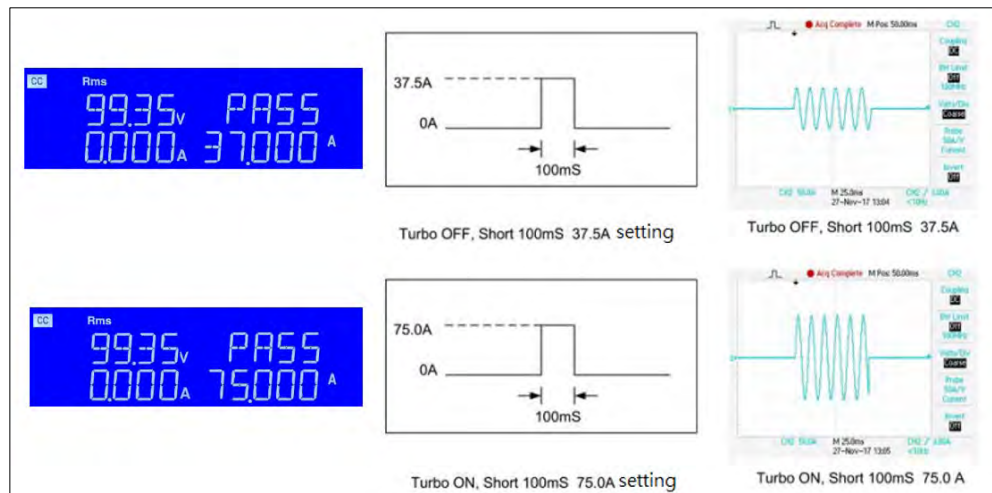

Figure 3-9: : Fuse Test Trip Mode - Normal and Turbo Mode

In the Trip test mode of the 3C Series load, the LCD shows the Repeat times and the trip time of the current protection component after the tested fuse blows.

In the Non-Trip test mode, the current protection component is required to achieve non-blow action, so the test current needs to be lower than the fuse current rating that is used to verify the fuse and it should not blow during normal current range. In this mode, the LCD display shows the Repeat number information after the tested fuse does not blow.

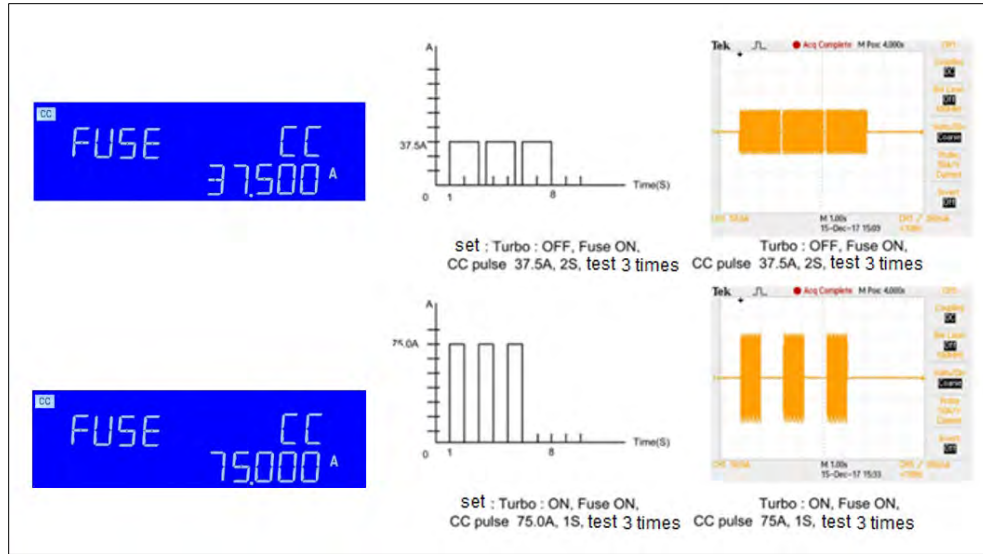

Figure 3-10: Fuse Test Non-trip Mode - Normal and Turbo Mode

The FUSE parameters setting:

Pressing the Item key once will cause the button to illuminate. The message “FUUSE PRESS START” will be shown across the displays.

Each press of the setting button moves the menu one step. The Left and right LCDs show the currently selected test parameter as text. The value can be adjusted by the rotary knob and can be read from the Right display during Setting.

The setting sequence is shown below:

- FUUSE PRESS START->
- FUUSE TURBO OFF ->
- FUUSE CC ->
- FUUSE TIME ->
- FUUSE REP. ->
- FUUSE TYPE TRIP ->

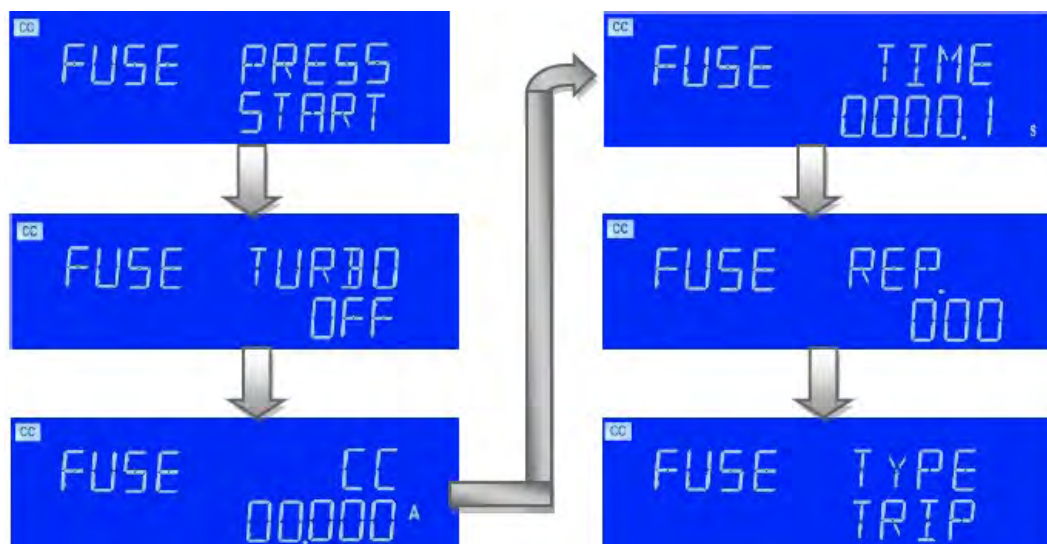

FUSE TURBO: set the fuse TURBO mode. The Left 5 digit monitor displays “FUSE”, the Right Upper 5 Digit monitor displays “TURBO” and right lower monitor will display OFF. Use the knob and the key to toggle ON or OFF.

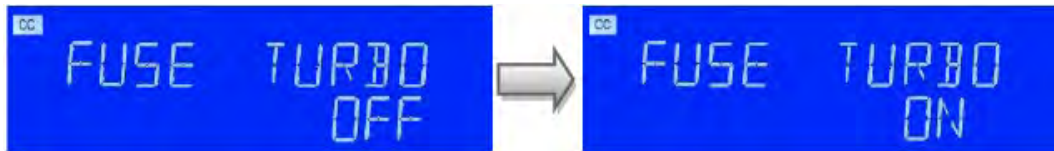

FUSE CC: set the fuse current rating value, the Left 5 digit monitor displays “FUSE”, the right upper 5 digit monitor displays “CC”, and the right lower monitor displays the set value in "A". Use the knob and button to set the FUSE CC current value the range from 0.000A to full scale current of the CC mode specification.

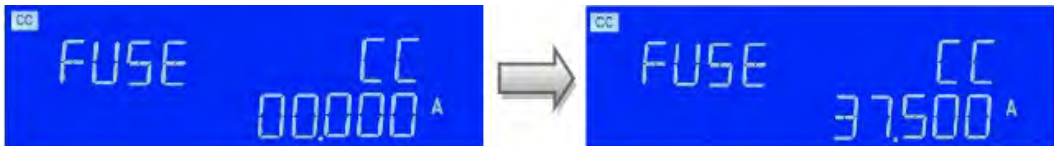

FUSE TIME: set the fuse test time, the Left 5 digit monitor displays “FUSE”, the right upper 5 digit monitor displays “TIME” and the right lower monitor displays the set value in seconds "S". Use the knob and button to set the range from 0.1 S ~ 9999.9 S.

Note: If the TURBO is ON, the maximum settable time is one second.

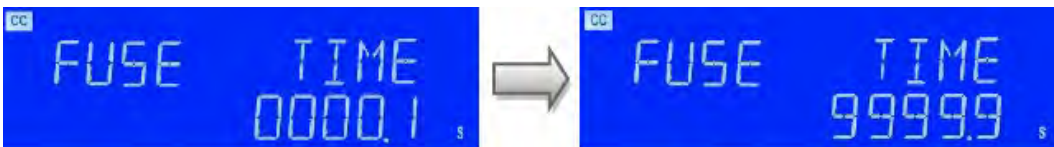

FUSE REP: set the fuse test time, the Left 5 digit monitor displays “FUSE”, the right upper 5 digit monitor displays “REP.” and the right lower monitor displays the set value. Use the knob and button to set the range from 0 to 255.

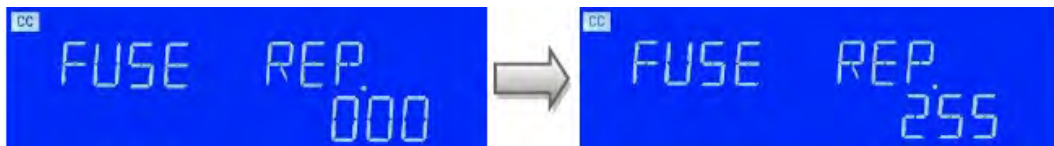

The right upper 5 digit monitor displays TYPE and the right lower monitor displays “TRIP”. Use the knob and the key to select TRIP or NTRIP.



3.4.6 Battery Test Functions

The 3C Series AC & DC electronic load has three dedicated battery test modes called TYPE1, TYPE2 and TYPE3. All are different forms of discharge tests. The user can select the desired battery test mode as needed. Test results are displayed on the LCD display and include battery AH capacity, remaining battery voltage after discharge and the cumulative discharge time data.

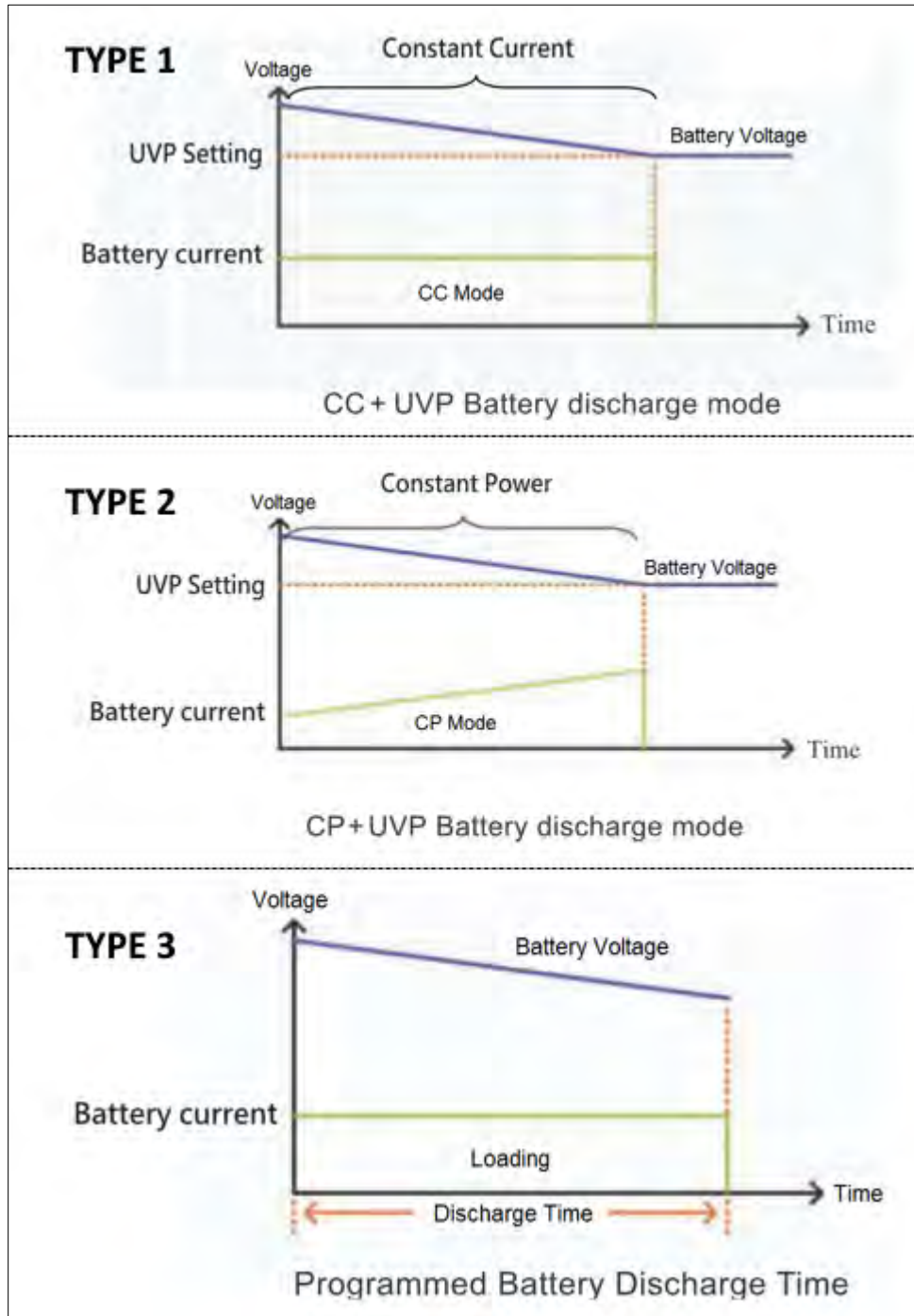

Figure 3-11: Battery Test Modes 1 ~ 3

The BATT parameters setting:

Pressing the Item key once will cause the button to illuminate. The message “BATT PRESS START” will be shown across the displays. Each press of the setting button moves the menu on one step. The Left and right LCDs show the currently selected test parameter as text. The value is adjusted using the rotary knob and can be read from the Right display during Setting.

The setting sequence is shown below:

- BATT PRESS START ->
- BATT MODE CC ->
- BATT CC ->
- BATT CF ->
- BATT PF LEAD ->
- BATT PF ->
- BATT TIME ->
- BATT VTH ->

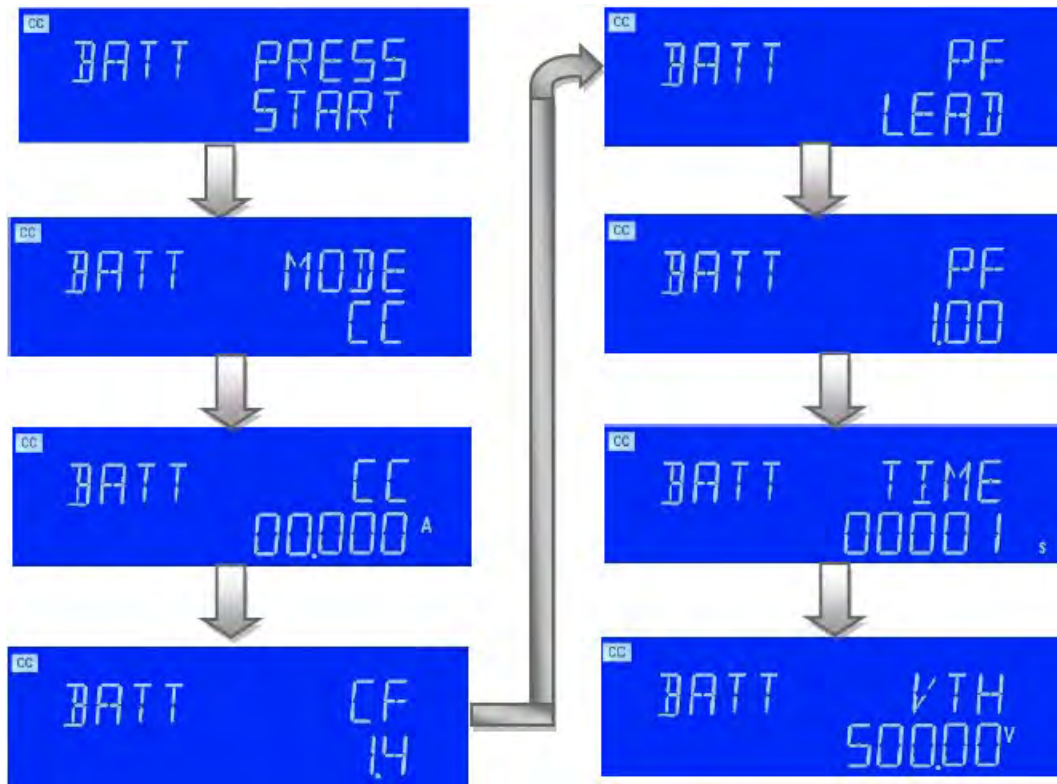

The Left 5 digit monitor displays “BATT”, the right upper 5 digit monitor displays “MODE” and right lower monitor display “CC”. Use the knob and the key to switch between CC, LIN, CR or CP.

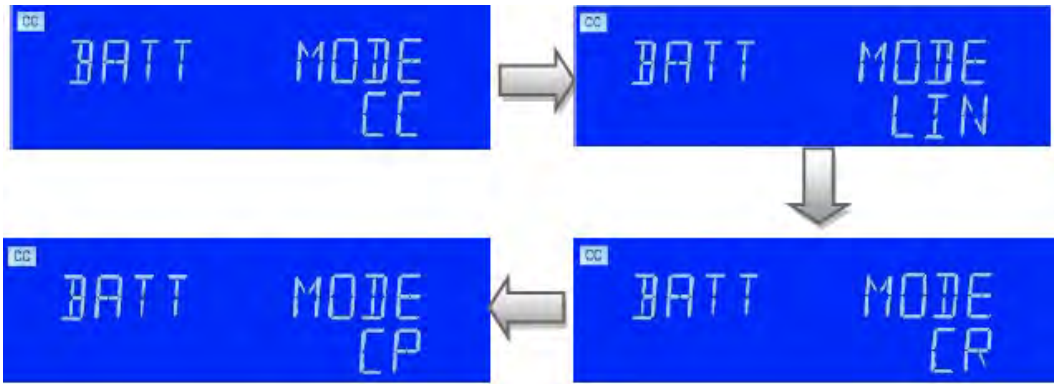

BATT CC: set the Battery current point, the Left 5 digit monitor display the “BATT”, the right upper 5 digit monitor display the “CC”, and the right lower monitor displays the set value in "A". The range is 0.001A to the full scale of the CC mode specification.

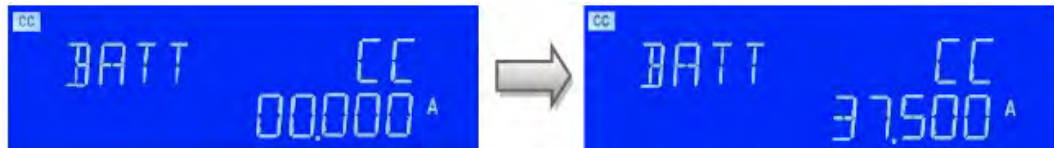

BATT CF: set the CF, the Left 5 digit monitor displays “BATT”, the right upper 5 digit monitor display “CF” and right lower monitor displays the set value.

The range is 1.0, 1.1, 1.2 1.3 1.4 ~ 5.0 and the setting sequence is shown below:

BATT CF 1.4 ~5.0 ->

(1.3) BATT CF TRAIL: Trailing edge ->

(1.2) BATT CF LEAD: Leading edge ->

(1.1) BATT CF LDNEG: negative half-cycle loading ->

(1.0) BATT CF LDPOS: positive half-cycle loading ->

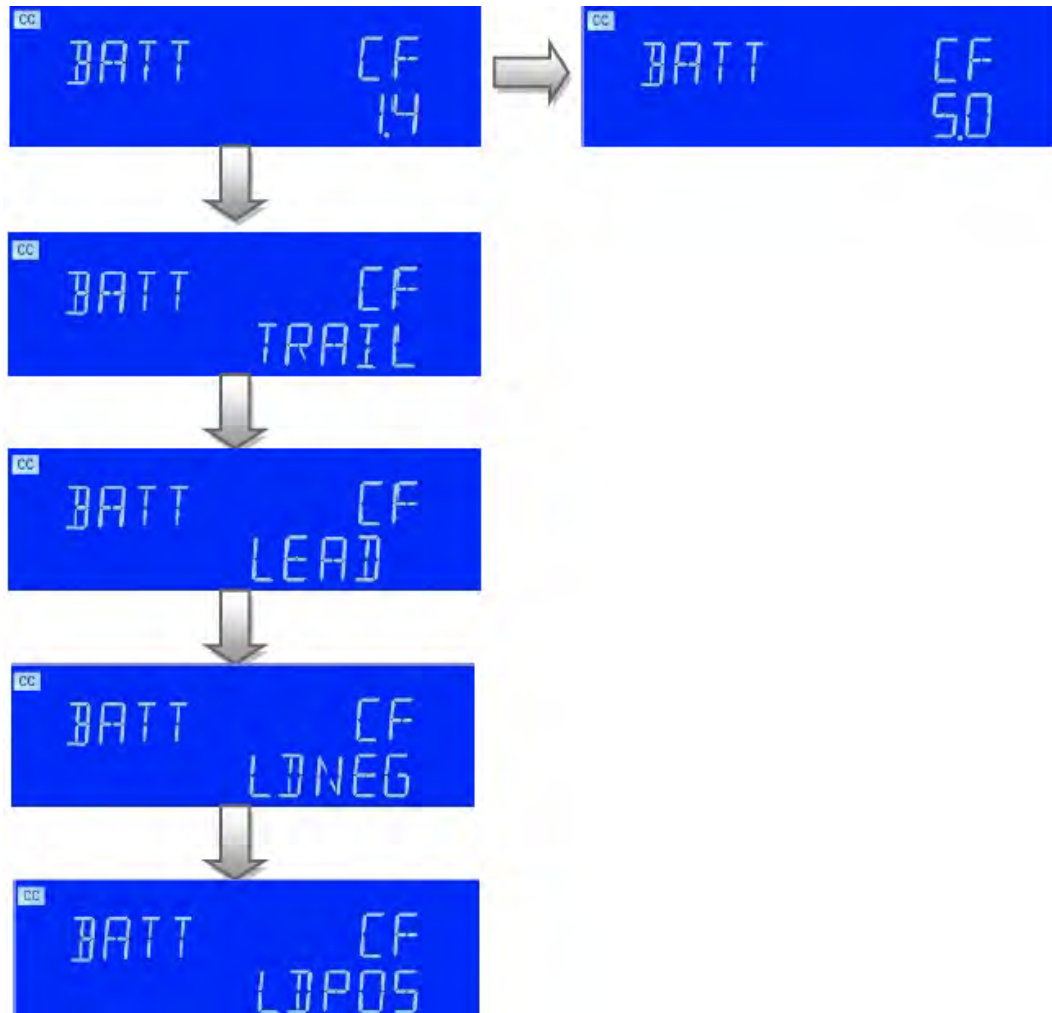

The Left 5 digit monitor displays “BATT”, the right upper 5 digit monitor displays “PF” and the right lower monitor displays “LEAD”. Use the knob and the key to select LEAD or LAG.



BATT CF: setting the PF, the Left 5 digit monitor displays “BATT”, the right upper 5 digit monitor displays “PF” and the right lower monitor displays the set value. The range is 0.01 ~ 1.00.

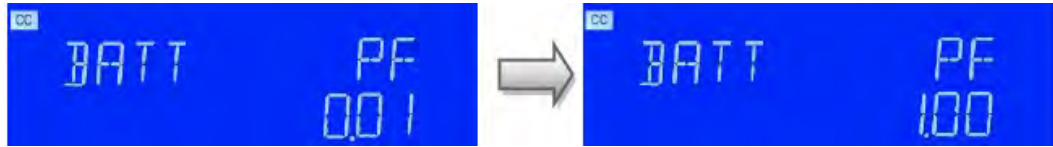

BATT TIME: set the Battery test time, the Left 5 digit monitor displays “BATT”, the right upper 5 digit monitor displays “TIME” and the right lower monitor displays the set value in seconds “S”. The range is 1S ~ 99999S.

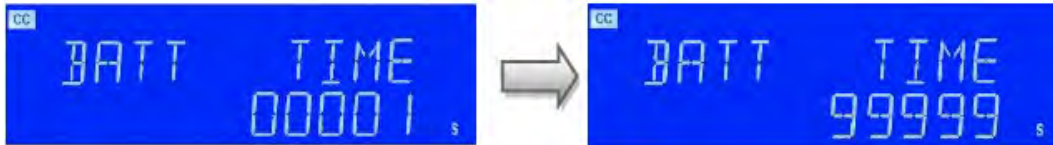

BATT VTH: the Left 5 digit monitor displays “BATT”, the right upper 5 digit monitor displays “VTH” and the right lower monitor displays the set value in “V”. The range is 0.01V to the full scale of the Voltage specification.

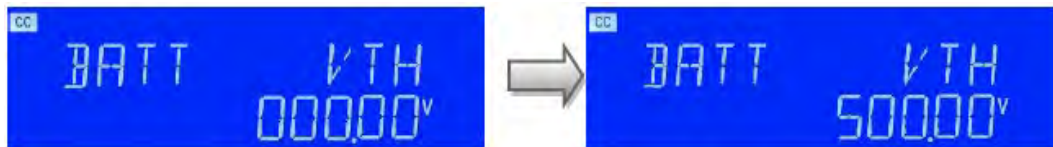

Press the Item key to enter the Item setting mode BATT PRESS START, the LED indicator is ON, and then press the setting key. The LED indicator is ON. To exit the setting, press the EXIT key and select LIN MODE. The setting sequence is as follows:

- BATT PRESS START ->
- BATT MODE LIN ->
- BATT LIN ->
- BATT TIME ->
- BATT VTH ->

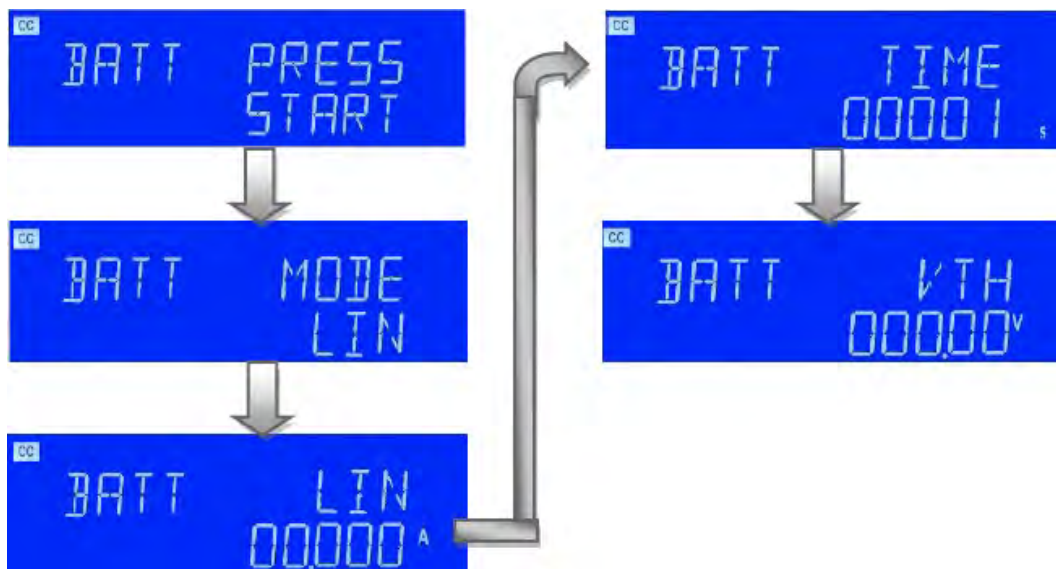

BATT LIN : setting the BATT LIN, the Left 5 digit monitor displays “BATT”, the right upper 5 digit monitor displays “LIN”, and the right lower monitor displays the set value in "A". The range is 0.001A to the full scale of the CC mode specification.



BATT TIME: setting the BATT TIME, the Left 5 digit monitor displays “BATT”, the right upper 5 digit monitor displays “TIME” and the right lower monitor displays the set value in seconds "S". The range is 1 s to the 99999 s.

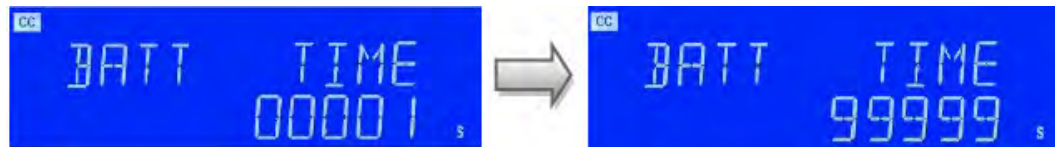

BATT Vth: Set BATT threshold voltage; the Left 5 digit monitor displays “BATT”, the right upper 5 digit monitor displays “VTH” and the right lower monitor displays the set value in "V". The range is 0.01V to the full scale of the Voltage specification.

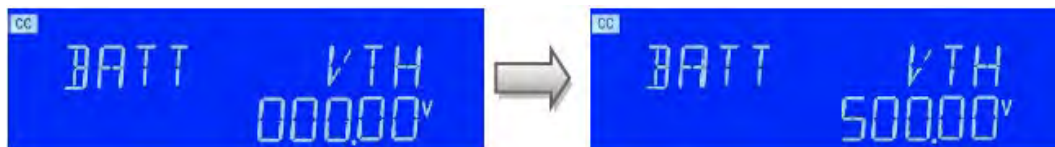

Press the Item key to enter the Item setting mode BATT PRESS START, the LED

Indicators is ON, and then press the setting key. The LED indicator is ON. To exit the setting, press the EXIT key and select CR MODE. The setting sequence is as follows:

- BATT PRESS START ->
- BATT MODE CR ->
- BATT LIN ->
- BATT TIME ->
- BATT VTH ->

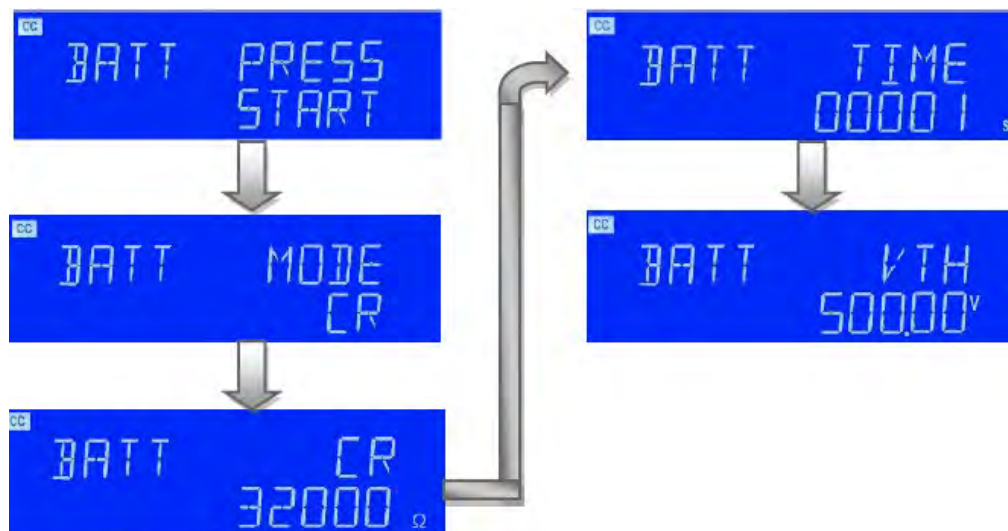

BATT CR: set the BATT CR, the Left 5 digit monitor displays the BATT", the right upper 5 digit monitor displays "CR", and the right lower monitor displays the set value in "Ω". The range is 1.6Ω to the full scale of the CR mode specification.

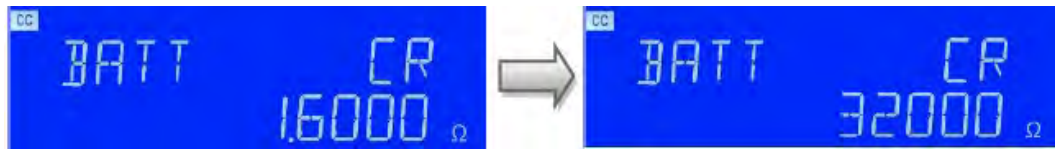

BATT TIME: set the BATT TIME, the Left 5 digit monitor displays "BATT", the right upper 5 digit monitor displays "TIME" and the right lower monitor displays the set value in seconds "S". The range is 1s to the 99999s.

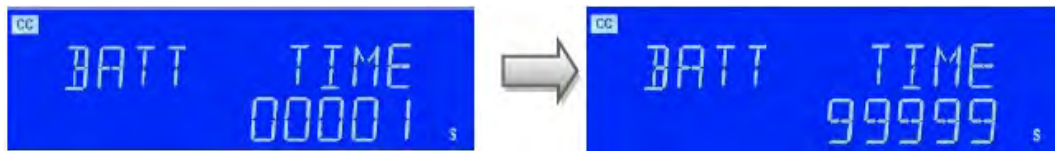

Press the Item key to enter the Item setting mode BATT PRESS START, the LED Indicator is ON, and then press the setting key. The LED indicator is ON. To exit the setting, press the EXIT key and select CP MODE. The setting sequence is as follows:

- BATT PRESS START ->
- BATT MODE CP ->
- BATT CP ->
- BATT CF ->
- BATT PF LEAD ->
- BATT PF ->
- BATT TIME ->
- BATT VTH ->

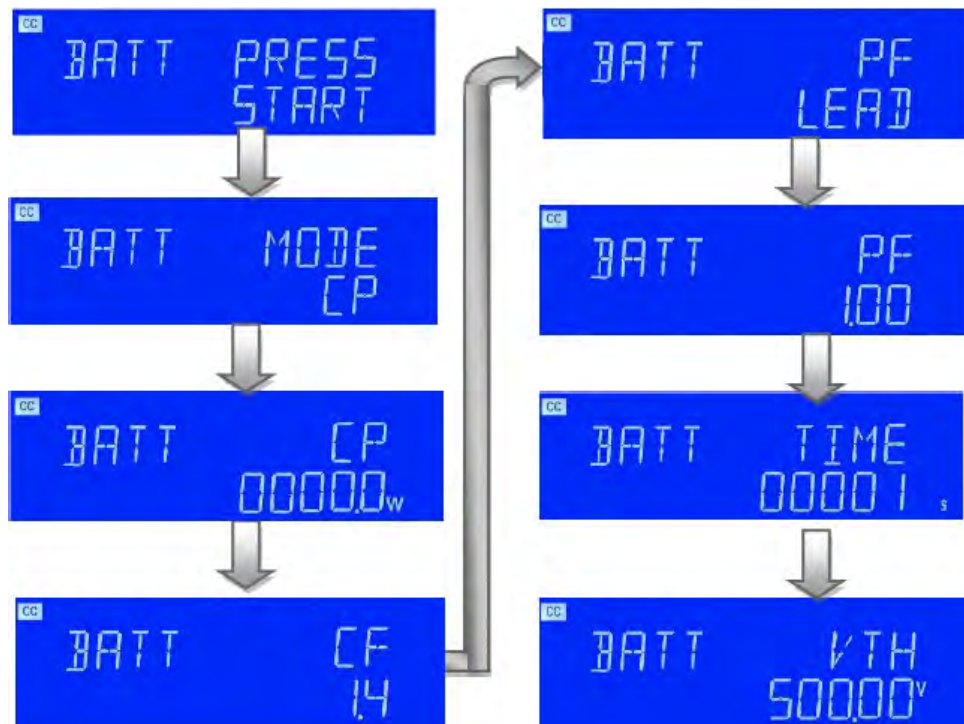

BATT CP: set the BATT CP, the Left 5 digit monitor displays “BATT”, the right upper 5 digit monitor displays “CP” and the right lower monitor displays the set value in "W". The range is 0.1W to the full scale of the CP mode specification.

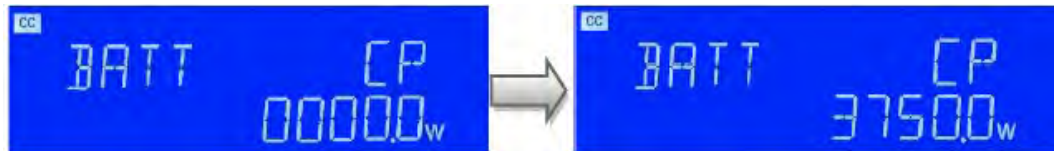

BATT CF: set the CF, the Left 5 digit monitor displays “BATT”, the right upper 5 digit monitor displays “CF” and the right lower monitor displays the set value. The range is 1.0, 1.1, 1.2, 1.3, 1.4 ~ 5.0. The setting sequence is shown below:

BATT CF 1.4 ~5.0 ->

- (1.3) BATT CF TRAIL: Trailing edge ->
- (1.2) BATT CF LEAD: Leading edge ->
- (1.1) BATT CF LDNEG: negative half-cycle loading ->
- (1.0) BATT CF LDPOS: positive half-cycle loading ->

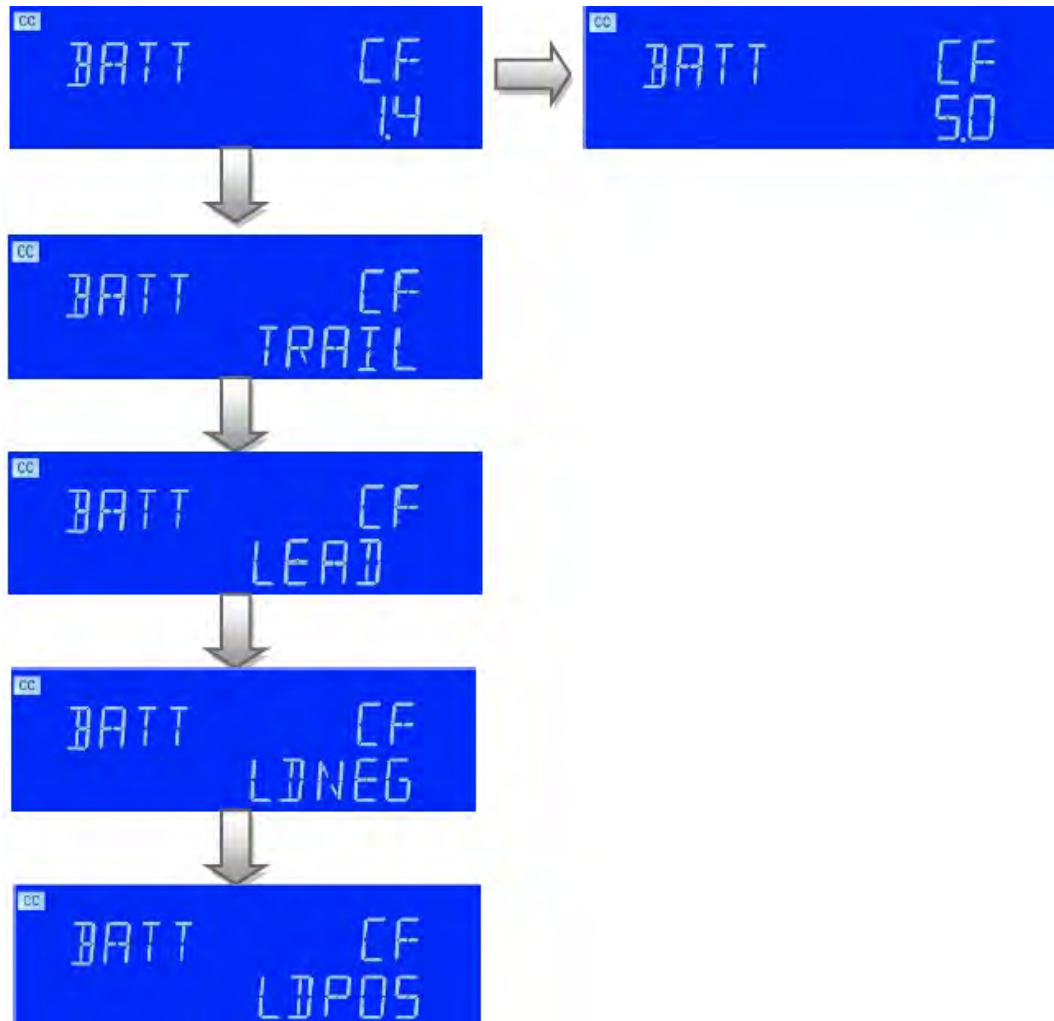

BATT CF: set the PF, the Left 5 digit monitor displays “BATT”, the right upper 5 digit monitor displays “PF” and the right lower monitor displays the setting value. The range is 0.01 ~ 1.00.

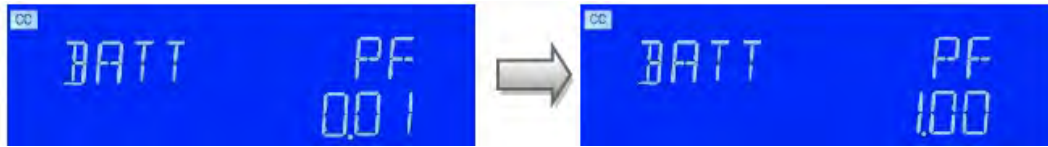

BATT TIME: set the Battery test time, the Left 5 digit monitor displays “BATT”, the right upper 5 digit monitor displays “TIME” and the right lower monitor displays the set value in seconds “S”. The range is 1 s ~ 99999 s.

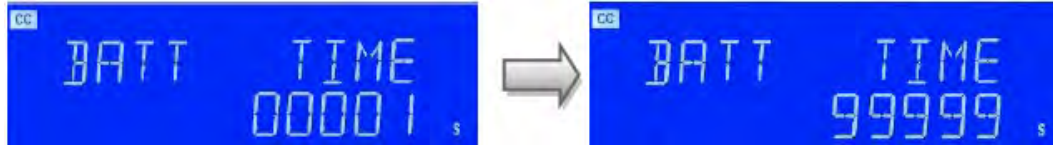

BATT VTH: set the high voltage, the Left 5 digit monitor displays “BATT”, the right upper 5 digit monitor displays “VTH”, and the right lower monitor displays the set value in “V”. The range is 0.01V to the full scale of the Voltage specification.

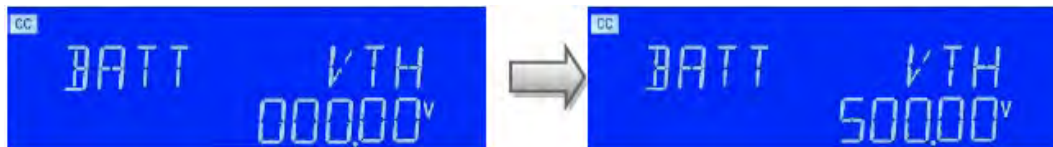

3.4.7 UPS Transfer Time Test

The TRANS parameters setting:

Pressing the Item key once will cause the button to illuminate. The message “TRANS PRESS START” will be shown across the displays.

Each press of the setting button moves the menu one step. The Left and right LCDs shows the currently selected test parameter as text. The value is adjusted by the rotary knob and can be read from the Right display during Setting.

The setting sequence is shown below:

TRANS PRESS START ->

TRANS CC ->

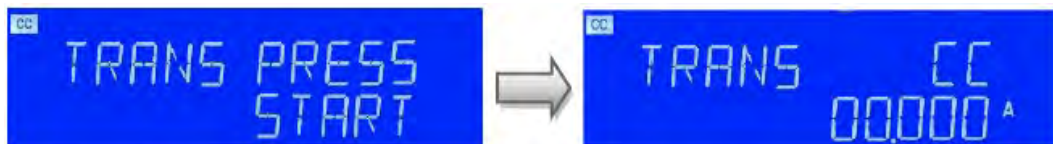

TRANS CC : set the Battery current point, the Left 5 digit monitor displays “TRANS”, the right upper 5 digit monitor displays “CC” and the right lower monitor displays the set value in “A”. The range is 0.001A to the full scale of the CC mode specification.



3.4.8 Inrush Current Mode

The Inrush current mode is shown on the display somewhat abbreviated as “INRUS”. In this mode of operation, the user can set the current limit to increase from a higher start value to a lower end value over a period of time in a defined number of steps. The combination of steps and time along with start and end current level will determine the rate of change of the current the AC load will sink.

This mode is intended to simulate the typical decaying inrush current when applying AC power to a rectifier capacitor input circuit of a load.



Available parameters for Inrush Mode are:

- ISTAR Initial Current level in A
- ISTEP Current Step Size in A
- ISTOP End Current Level – Load will maintain this level after inrush period
- ITIME Time delay between each current step in msec

The user selects INRUS mode and sets frequency, start current, current step size, end current and time duration. With inrush mode set and armed, the AC load waits for the AC voltage to be turned on and immediately executes the programmed inrush current profile. An example is shown below. In this example ISTAR = 20A, ISTEP = 1A, ISTOP = 10A and ITIME = 16.667



What makes the INRUSH mode unique is the fact that the 3C Load does not need to sync up to the AC input voltage first before applying the programmed initial current level so there is no single or multi period delay before current starts to sink.

The INRUS parameters setting:

Pressing the Item key once will cause the button to illuminate. The message “INRUS PRESS START” will be shown across the displays. Each press of the setting button moves the menu on one step. The Left and right LCDs show the currently selected test parameter as text. The value is adjusted by The rotary knob and can be read from the Right display during Setting.

The setting sequence is shown below:

- INRUS PRESS START ->
- INRUS FREQ ->
- INRUS ISTAR ->
- INRUS ISTEP ->
- INRUS TIME ->
- INRUS ISTOP ->



INRUS FREQ: set the INRUS FREQ, the Left 5 digit monitor displays “INRUS”, the right upper 5 digit monitor displays “FREQ” and the right lower monitor displays the set value in "Hz". Use the knob and button to set in the range from DC and 40~ 440Hz.

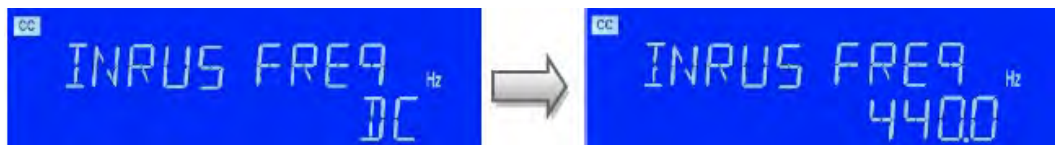

INRUS ISTAR: set the INRUS ISTAR, the Left 5 digit monitor displays “INRUS”, the right upper 5 digit monitor displays “ISTAR” and the right lower monitor displays the set value in "A". Use the knob and button to set the starting current value, the setting range from 0.000 A to 75.000A.

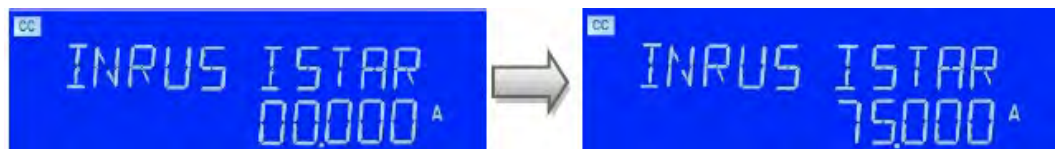

INRUS ISTEP: set the INRUS ISTEP, the Left 5 digit monitor displays “INRUS”, the right upper 5 digit monitor displays “ISTEP” and the right lower monitor displays the set value in "A". Use the knob and button to set the ISTEP current value, the setting range from 0.000 A to 75.000A.

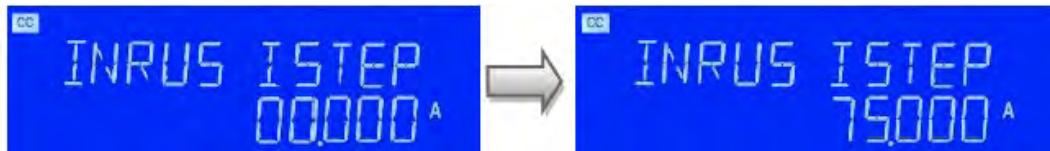

INRUS TIME: set the INRUS TIME, the Left 5 digit monitor displays “INRUS”, the right upper 5 digit monitor displays “TIME” and the right lower monitor displays the set value in "ms". Use the knob and button to set the time, the setting range from 0.1ms to the 100.0ms.

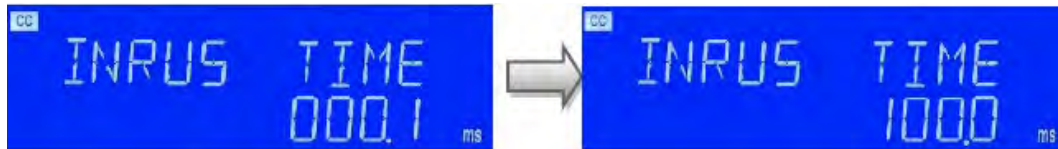

INRUS ISTOP: set the INRUS ISTOP, the Left 5 digit monitor displays “INRUS”, the right upper 5 digit monitor displays “ISTOP” and the right lower monitor displays the set value in "A". Use the knob and button to set the ISTOP current value, the setting range from 0.000 A to 37.500A.

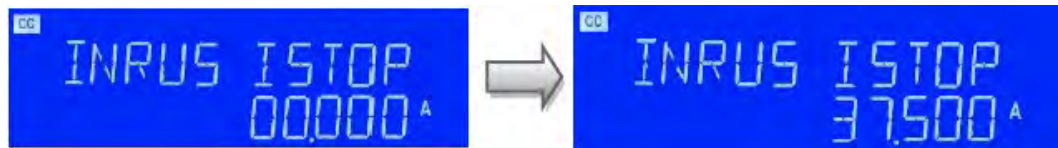

3.4.9 Current SurgeTest

The SURGE parameters setting:

Pressing the Item key once will cause the button to illuminate. The message “SURGE PRESS START” will be shown across the displays.

Each press of the setting button moves the menu one step. The Left and right LCDs show the currently selected test parameter as text. The value is adjusted using the rotary knob and can be read from the right display during Setting.

The setting sequence is shown below:

- SURGE PRESS START ->
- SURGE FREQ ->
- SURGE S1 ->
- SURGE T1 ->
- SURGE S2 ->
- SURGE T2 ->
- SURGE S3 ->
- SURGE T3 ->

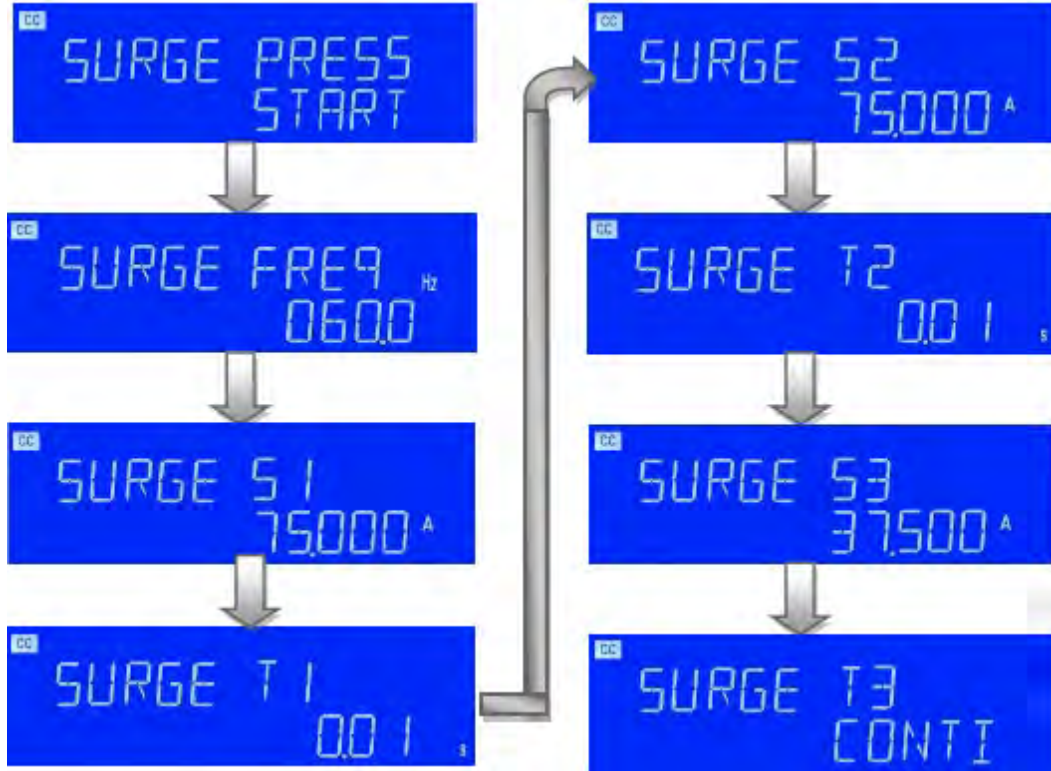

SURGE FREQ: setting the SURGE FREQ, the Left 5 digit monitor display the “SURGE”, the right upper 5 digit monitor display the “FREQ”, and the right lower monitor displays the set value in "Hz", use the knob and button to set the Frequency value, the setting range from DC and 40~440Hz.

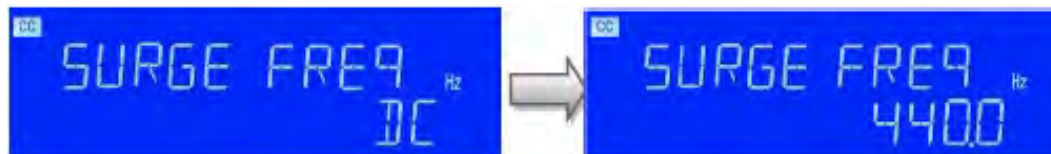

SURGE S1 :setting the SURGE S1, the Left 5 digit monitor display the “SURGE” ,the right upper 5 digit monitor display the “S1”, and the right lower monitor display the set value in "A". Use the knob and button to set the first surge current value, the setting range from 0.000A to the 75.000A.



SURGE T1: setting the SURGE T1, the Left 5 digit monitor display the "SURGE", the right upper 5 digit monitor display the "T1", and the right lower monitor displays the set value in "S", use the knob and button to set the first surge current time value, the setting range from 0.01s to the 0.50s.

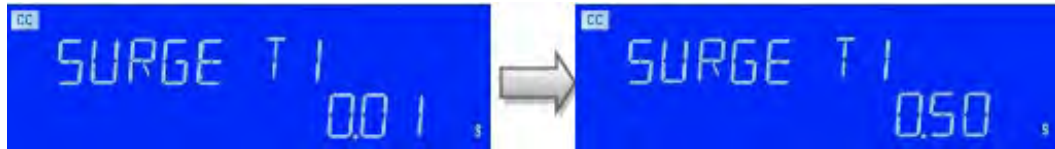

SURGE S2 : setting the SURGE S2, the Left 5 digit monitor display the "SURGE", the right upper 5 digit monitor display the "S2", and the right lower monitor displays the set value in "A", use the knob and button to set the second surge current value, the setting range from 0.000A to the 75.000A.

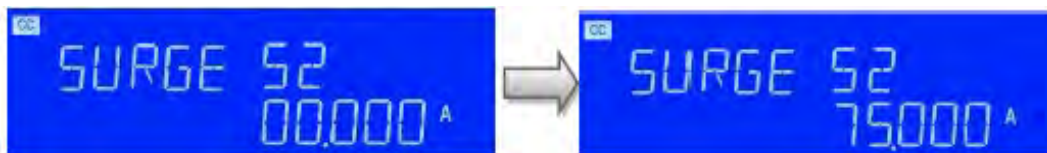

SURGE T2 : setting the SURGE T2, the Left 5 digit monitor display the "SURGE", the right upper 5 digit monitor display the "T2", and the right lower monitor display the set value in "S", use the knob and button to set the second surge current time value, the setting range from 0.01s to the 0.50s.

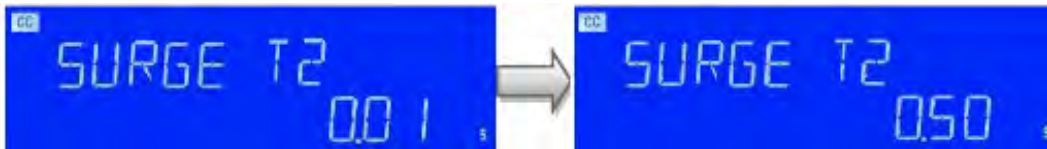

SURGE S3 : setting the SURGE S3, the Left 5 digit monitor display the "SURGE", the right upper 5 digit monitor display the "S3", and the right lower monitor displays the set value in "A". Use the knob and button to set the Third surge current value, the setting range from 0.000A to the 37.500A.



SURGE T3 : setting the SURGE T3, the Left 5 digit monitor display the "SURGE", the right upper 5 digit monitor display the "T3", and the right lower monitor displays the set value in seconds "S". Use the knob and button to set the third surge current time value, the setting range from CONTI to the 9.99s

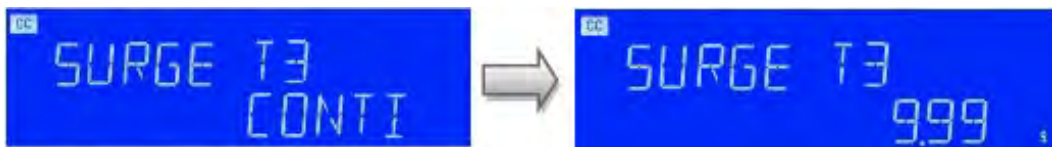

3.5 Current Read-back

The current levels and load status for each load can be set from the front panel or over the remote control interface. During testing, load input voltage and load current can be read back but the current read back will typically display the average current level unless the dynamic current frequency setting is low enough. An analog current monitor output is provided to allow capturing of dynamic current on a digital storage scope or data recorder.

3.6 External Sync Mode

An external Sync input BNC connector is provided at the rear panel of the load chassis. This input allows for synchronization of the AC current with an external reference. Without an external sync signal, the AC source will sink to the sensed AC voltage using its internal zero crossing detection circuit.

Note: This mode is supported in Constant Current (CC) and Linear Current (LIN) modes only.

3.7 Product Features

The following key characteristics apply to all 3C Series models.

- Fully programmable electronic AC & DC load with flexible configuration and dual range capabilities.
- Fully remote control of all load settings and metering read back.
- High accuracy and high-resolution voltage, current and power meters.
- DC or 0.1 Hz to 800 Hz frequency range support (CC, CC LIN and CR modes).
- DC, 40Hz to 440Hz for all other modes.
- Power factor (PF) and crest factor (CF) control (CC mode).
- Load ON/OFF switch change and power supply turn ON.
- Internal or external voltage sensing.
- Automatic Go/NoGo testing.
- Full protection from over power, over temperature, over voltage, and reverse polarity.
- Analog current monitor output (I-Monitor).
- External sync input.
- Variable speed fan control for quiet operation.

3.8 Accessories Included

The following accessories are included in the ship kit for each 3C Series AC & DC load. If one or more of these is missing upon incoming inspection of the product, please contact Adaptive Power Systems customer service.

Item	Quantity
Operation Manual in hardcopy or PDF Format (Download at https://tr.adaptivepower.com/ User login required.)	1
AC Line Cord	1
Rack Handles (detachable)	2
Round Terminal RVL1-4 (Insulated Ring Terminal)	2
Round Terminal RNYBS8-4 (Nylon Ring Lug, 8 AWG, #8 Stud)	2
Terminal PTV1-12 (For use with Analog I/O Connector)	6
HD DSUB 15 pin Male to Male, 150 cm / 59"	1
Certificate of Conformance	1

Table 3-1: Included Accessories

3.8.1 Terminal RVL1-4 Specs

<p>Notes:</p> <ol style="list-style-type: none"> Maximum Electric Current: $\frac{\text{AWG}}{\text{AMP}} \begin{matrix} 22 & 20 & 18 & 16 \\ 9 & 12 & 17 & 18 \end{matrix}$ Maximum Electric Rating: 105°C 600 Volts Max Insulation Material: Vinyl Insulation Color: Red Terminal Material: Copper Wire Range: 22-16 AWG (0.5-1.5mm²) Terminal Surface Treatment: Tin Plated Terminal Thickness: 0.75mm 							
<p>Standard (Metric)</p> <p>0.82" (20.8mm) 0.28" (7mm) 0.39" (10mm) 0.31" (8mm) 0.17" (4.3mm) 0.07" (1.7mm) 0.16" (4mm)</p>		<p>Tolerances (Unless Otherwise Specified)</p>					
CATEGORY	Vinyl Insulated Ring Terminals	SCALE	4/1				
PART #	RVL1-4						
MATERIAL	Tin-Plated Copper						

3.8.2 Terminal RNYBS8-4 Specs

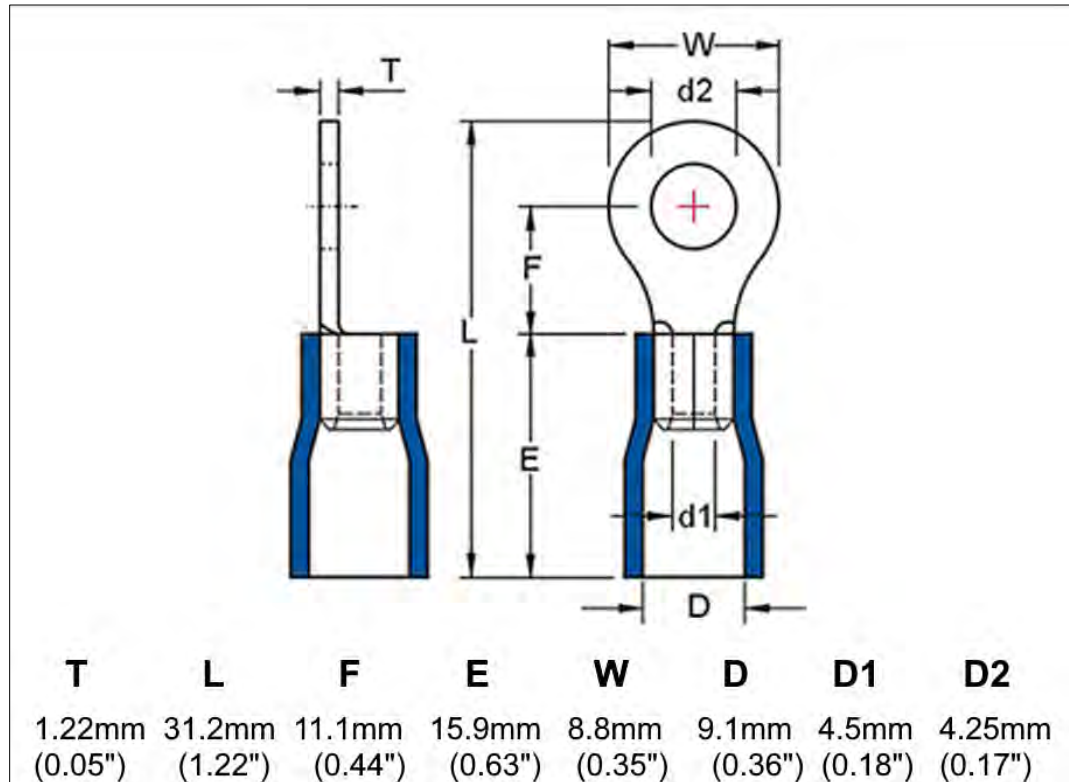

3.8.3 Terminal PTV1-12 Specs

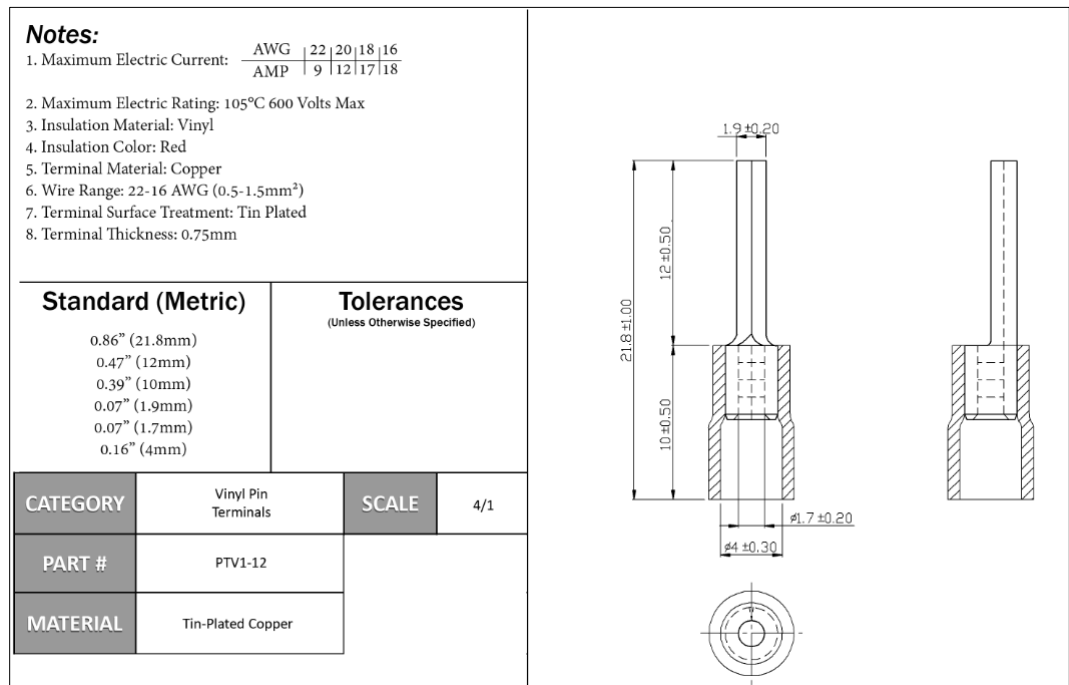

4 Technical Specifications

Technical specifications shown here apply at an ambient temperature of 25° C ± 5°. Refer to V-I curve and Very Low Voltage V-I Curve charts by models for operating envelope.

4.1 Operating Ranges

MODEL	3C018-18	3C028-18-EV	3C028-28	3C038-28-EV	3C038-38	
OPERATING RANGES						
Power Ranges	0 - 1875 VA / W		0 - 2800 VA / W		0 - 3750 VA / W	
Current (Arms Apk)	0-18.75	56.25	0-18.75	56.25	0-28.0	84.0
Voltage Ranges ¹	50 - 350 Vrms/ 500 Vdc		50 - 480 Vrms/ 700 Vdc		50 - 350 Vrms/ 500 Vdc	
Frequency	DC, 40-440 Hz in CC & CP Modes, DC-440 Hz in LIN, CR & CV Modes, Up to 800Hz in CC, LIN & CR Modes					
AC Waveforms	Sine, Square, Step, DC					

MODEL	3C056-56	3C075-75	3C112-112
OPERATING RANGES			
Power Ranges	0 - 5600 VA / W		0 - 11250 VA / W
Current (Arms Apk)	0-56.0	168.0	0-112.5
Voltage Range	50 - 350 Vrms/ 500.0 Vdc		
Frequency	DC, 40-440 Hz in CC & CP Modes, DC-440 Hz in LIN, CR & CV Modes, Up to 800Hz in CC, LIN & CR Modes		
AC Waveforms	Sine, Square, Step, DC		

MODEL	3C150-112	3C188-112	3C225-112
OPERATING RANGES			
Power Ranges	0 - 15000 VA / W		0 - 22500 VA / W
Current (Arms Apk)	0-56.0	168.0	0-112.5
Voltage Range	50 - 350 Vrms/ 500.0 Vdc		
Frequency	DC, 40-440 Hz in CC & CP Modes, DC-440 Hz in LIN, CR & CV Modes, Up to 800Hz in CC, LIN & CR Modes s		
AC Waveforms	Sine, Square, Step, DC		

4.2 Operating Modes

MODEL	3C018-18	3C028-18-EV	3C028-28	3C038-28-EV	3C038-38
OPERATING MODES					
Constant Current Mode - Sinewave					
Range	0 - 18.75 A	0 - 18.75 A	0 - 28.0 A	0 - 28.0 A	0 - 37.5 A
Resolution	0.3125 mA / 16 bits	0.3125 mA / 16 bits	0.467 mA / 16 bits	0.467 mA / 16 bits	0.625 mA / 16 bits
Accuracy	50Hz & 60Hz: ± (0.1% SETTING + 0.2% RANGE) / > 60 Hz: ± (0.5% SETTING + 0.5% RANGE)				
Linear Constant Current Mode - Sinewave, Square Wave, Quasi-Square Wave. PWM Wave					
Range	0 - 18.75 A	0 - 18.75 A	0 - 28.0 A	0 - 28.0 A	0 - 37.5 A
Resolution	0.3125 mA / 16 bits	0.3125 mA / 16 bits	0.467 mA / 16 bits	0.467 mA / 16 bits	0.625 mA / 16 bits
Accuracy	50Hz & 60Hz: ± (0.1% SETTING + 0.2% RANGE) / > 60 Hz: ± (0.5% SETTING + 0.5 % RANGE)				

¹ 350Vac/500Vdc Models may be ordered with optional Extended Voltage Range (-EV Option) to 425Vac/600Vdc

MODEL	3C018-18	3C028-18-EV	3C028-28	3C038-28-EV	3C038-38
Constant Resistance Mode					
Range	3.2 Ohm - 64 KOhm	3.2 Ohm - 64 KOhm	2.133 Ohm - 42.66 KOhm	2.133 Ohm - 42.66 KOhm	1.6 ohm - 32 KOhm
Resolution	0.010416 mS / 16 bits	0.010416 mS / 16 bits	0.0078137 mS / 16 bits	0.0078137 mS / 16 bits	0.0052083 mS / 16 bits
Accuracy	50Hz & 60Hz: $\pm (0.2\% \text{ SETTING} + 0.2\% \text{ RANGE})$ / > 60 Hz: $\pm (0.5\% \text{ SETTING} + 2\% \text{ RANGE})$				
Constant Voltage Mode					
Range	50 - 350 Vrms/ 500 Vdc	50 - 480 Vrms/ 700 Vdc	50 - 350 Vrms/ 500 Vdc	50 - 480 Vrms/ 700 Vdc	50 - 350 Vrms/ 500 Vdc
Resolution ⁽¹⁾	0.1 V				
Accuracy	$\pm (0.1\% \text{ SETTING} + 0.1\% \text{ RANGE})$				
Constant Power Mode					
Range	1875 VA / W	2800 VA / W	2800 VA / W	3750 VA / W	3750 VA / W
Resolution	0.1 VA / W	0.1 VA / W	0.1 VA / W	0.1 VA / W	0.1 VA / W
Accuracy	$\pm (0.1\% \text{ SETTING} + 0.1\% \text{ RANGE})$				

MODEL	3C056-56	3C075-75	3C112-112
OPERATING MODES			
Constant Current Mode - Sinewave			
Range	0 – 56.0 A	0 – 75.0 A	0 – 112.5 A
Resolution	1.0 mA / 16 bits	1.25 mA / 16 bits	1.875 mA / 16 bits
Accuracy	50Hz & 60Hz: $\pm (0.1\% \text{ SETTING} + 0.2\% \text{ RANGE})$ / > 60 Hz: $\pm (0.5\% \text{ SETTING} + 0.5\% \text{ RANGE})$		
Linear Constant Current Mode - Sinewave, Square Wave, Quasi-Square Wave. PWM Wave			
Range	0 – 56.0 A	0 – 75.0 A	0 – 112.5 A
Resolution	1.00 mA / 16 bits	1.25 mA / 16 bits	1.875 mA / 16 bits
Accuracy	50Hz & 60Hz: $\pm (0.1\% \text{ SETTING} + 0.2\% \text{ RANGE})$ / > 60 Hz: $\pm (0.5\% \text{ SETTING} + 0.5\% \text{ RANGE})$		
Constant Resistance Mode			
Range	1.67 ohm - 16 KOhm	0.8 ohm - 16 KOhm	0.533 ohm – 10.666 KOhm
Resolution	0.015324 mS / 16 bits	0.020832 mS / 16 bits	0.031248 mS / 16 bits
Accuracy	50Hz & 60Hz: $\pm (0.2\% \text{ SETTING} + 0.2\% \text{ RANGE})$ / > 60 Hz: $\pm (0.5\% \text{ SETTING} + 2\% \text{ RANGE})$		
Constant Voltage Mode			
Range	50 - 350 Vrms/ 500.0 Vdc		
Resolution ⁽¹⁾	0.1 V		
Accuracy	$\pm (0.1\% \text{ SETTING} + 0.1\% \text{ RANGE})$		
Constant Power Mode			
Range	0 - 7500 VA / W	0 - 7500 VA / W	0 - 11250 VA / W
Resolution	0.1 VA / W	0.1 VA / W	1.0 VA / W
Accuracy	$\pm (0.1\% \text{ SETTING} + 0.1\% \text{ RANGE})$		

MODEL	3C150-112	3C188-112	3C225-112
OPERATING MODES			
Constant Current Mode - Sinewave			
Range	0 – 112.5 A		
Resolution	1.875 mA / 16 bits		
Accuracy	50Hz & 60Hz: $\pm (0.1\% \text{ SETTING} + 0.2\% \text{ RANGE})$ / > 60 Hz: $\pm (0.5\% \text{ SETTING} + 0.5\% \text{ RANGE})$		
Linear Constant Current Mode - Sinewave, Square Wave, Quasi-Square Wave. PWM Wave			
Range	0 – 112.5 A		
Resolution	1.875 mA / 16 bits		
Accuracy	50Hz & 60Hz: $\pm (0.1\% \text{ SETTING} + 0.2\% \text{ RANGE})$ / > 60 Hz: $\pm (0.5\% \text{ SETTING} + 0.5\% \text{ RANGE})$		
Constant Resistance Mode			

MODEL	3C150-112	3C188-112	3C225-112
Range	0.533 ohm – 10.666 KOhm		
Resolution	0.031248 mS / 16 bits		
Accuracy	50Hz & 60Hz: ± (0.2% SETTING + 0.2% RANGE) / > 60 Hz: ± (0.5% SETTING + 2% RANGE)		
Constant Voltage Mode			
Range	50 - 350 Vrms/ 500.0 Vdc		
Resolution ⁽¹⁾	0.1 V		
Accuracy	± (0.1% SETTING + 0.1% RANGE)		
Constant Power Mode			
Range	0 - 15000 VA / W	0 - 18750 VA / W	0 - 22500 VA / W
Resolution	1.0 VA / W	2.0 VA / W	2.0 VA / W
Accuracy	± (0.1% SETTING + 0.1% RANGE)		

4.3 Test Modes

MODEL	3C018-18	3C028-18-EV	3C028-28	3C038-28-EV	3C038-38
TEST MODES					
UPS Efficiency Measurement (Non-linear Mode)					
Operating Frequency	Auto / 40 - 440 Hz				
Current Range	0 - 18.75 A	0 - 18.75 A	0 - 28.0 A	0 - 28.0 A	0 - 37.5 A
P.F. Range	0.00 ~ 1.00				
Measuring Efficiency for PV Systems and Power Conditioners for THD 80% Resistive + Non Linear CC Mode					
Operating Frequency	Auto / 40 - 440 Hz				
Current Range	0 - 18.75 A	0 - 18.75 A	0 - 28.0 A	0 - 28.0 A	0 - 37.5 A
Resistive Range	3.2 Ohm-64 KOhm	3.2 Ohm-64 KOhm	2.133 Ohm - 42.66 KOhm	2.133 Ohm - 42.66 KOhm	1.6 Ohm - 32 KOhm
UPS Back-up Function (CC, LIN, CR, CP Modes)					
UVP (VTH)	50 - 350 Vrms / 500 Vdc				
UPS Back-up Time	1 - 99,999 Sec. (> 27 Hours)				
Battery Discharge Function (CC, LIN, CR, CP Modes)					
UVP (VTH)	50 - 350 Vrms / 500 Vdc	50 - 480 Vrms / 700 Vdc	50 - 350 Vrms / 500 Vdc	50 - 480 Vrms / 700 Vdc	50 - 350 Vrms / 500 Vdc
Battery Discharge Time	1 - 99,999 Sec. (> 27 Hours)				
UPS Transfer Time					
Current Range	0 - 18.75 A	0 - 28.0 A	0 - 37.5 A		
UVP (VTH)	2.5 V				
Time Range	0.15 mSec - 999.99 mSec				
Fuse Test Mode					
Max. Current	18.75A / 37.5A w Turbo mode ON	18.75A / 37.5A w Turbo mode ON	0 - 28.0A / 56.0A w Turbo mode ON	0 - 28.0A / 56.0A w Turbo mode ON	0 - 37.5A / 75A w Turbo mode ON
Trip Time	0.1 – 9999.9 sec w Turbo mode OFF / 0.1 - 1.0 sec w Turbo mode ON				
Accuracy / Repeat Cycles	± 0.003 sec / 0 - 255				
Trip & Non-Trip Times	0.1 - 9999.9 Sec w Turbo mode OFF / 0.1 - 1.0 Sec w Turbo mode ON				
Measurement Accuracy	± 0.003 Sec				
Repeat Count	0 - 255				
Short / OPP / OCP Test Function - Turbo Mode Available					
Short Time	0.1-10 Sec / Cont. w Turbo mode OFF / 0.1 - 1.0 Sec w Turbo mode ON				
OPP / OCP Step Time	100 ms w Turbo mode OFF / 100 ms up to 10 steps w Turbo mode ON				

MODEL	3C056-56	3C075-75	3C112-112
TEST MODES			
UPS Efficiency Measurement (Non-linear Mode)			
Operating Frequency	Auto / 40 - 440 Hz		
Current Range	0 – 56.0 A	0 – 75.0 A	0 - 112.5 A
P.F. Range	0.00 ~ 1.00		
Measuring Efficiency for PV Systems and Power Conditioners for THD 80% Resistive + Non Linear CC Mode			
Operating Frequency	Auto / 40 - 440 Hz		
Current Range	0 – 56.0 A	0 – 75.0 A	0 - 112.5 A
Resistive Range	1.00 mA / 16 bits	1.25 mA / 16 bits	0.533 Ohm – 10.666 KOhm
UPS Back-up Function (CC, LIN, CR, CP Modes)			
UVP (VTH)	50 - 350 Vrms / 500 Vdc		
UPS Back-up Time	1 - 99,999 Sec. (> 27 Hours)		
Battery Discharge Function (CC, LIN, CR, CP Modes)			
UVP (VTH)	50 - 350 Vrms / 500 Vdc		
Battery Discharge Time	1 - 99,999 Sec. (> 27 Hours)		
UPS Transfer Time			
Current Range	0 – 56.0 A	0 – 75.0 A	0 - 112.5 A
UVP (VTH)	2.5 V		
Time Range	0.15 mSec - 999.99 mSec		
Fuse Test Mode			
Max. Current	0 - 56A / 112.5A w Turbo mode ON	0 - 75A / 150A w Turbo mode ON	0 - 112.5A / 225A w Turbo mode ON
Trip Time	0.1 – 9999.9 sec w Turbo mode OFF / 0.1 - 1.0 sec w Turbo mode ON		
Accuracy / Repeat Cycles	± 0.003 sec / 0 - 255		
Trip & Non-Trip Times	0.1 - 9999.9 Sec w Turbo mode OFF / 0.1 - 1.0 Sec w Turbo mode ON		
Measurement Accuracy	± 0.003 Sec		
Repeat Count	0 - 255		
Short / OPP / OCP Test Function - Turbo Mode Available			
Short Time	0.1-10 Sec / Cont. w Turbo mode OFF / 0.1 - 1.0 Sec w Turbo mode ON		
OPP / OCP Step Time	100 ms w Turbo mode OFF / 100 ms up to 10 steps w Turbo mode ON		

MODEL	3C150-112	3C188-112	3C225-112
TEST MODES			
UPS Efficiency Measurement (Non-linear Mode)			
Operating Frequency	Auto / 40 - 440 Hz		
Current Range	0 - 112.5 A		
P.F. Range	0.00 ~ 1.00		
Measuring Efficiency for PV Systems and Power Conditioners for THD 80% Resistive + Non Linear CC Mode			
Operating Frequency	Auto / 40 - 440 Hz		
Current Range	0 - 112.5 A		
Resistive Range	0.533 Ohm – 10.666 KOhm		
UPS Back-up Function (CC, LIN, CR, CP Modes)			
UVP (VTH)	50 - 350 Vrms / 500 Vdc		
UPS Back-up Time	1 - 99,999 Sec. (> 27 Hours)		
Battery Discharge Function (CC, LIN, CR, CP Modes)			
UVP (VTH)	50 - 350 Vrms / 500 Vdc		
Battery Discharge Time	1 - 99,999 Sec. (> 27 Hours)		

MODEL	3C150-112	3C188-112	3C225-112
UPS Transfer Time			
Current Range	0 - 112.5 A		
UVP (VTH)	2.5 V		
Time Range	0.15 mSec - 999.99 mSec		
Fuse Test Mode			
Max. Current	0 - 112.5A / 225A w Turbo mode ON		
Trip Time	0.1 – 9999.9 sec w Turbo mode OFF / 0.1 - 1.0 sec w Turbo mode ON		
Accuracy / Repeat Cycles	± 0.003 sec / 0 - 255		
Trip & Non-Trip Times	0.1 - 9999.9 Sec w Turbo mode OFF / 0.1 - 1.0 Sec w Turbo mode ON		
Measurement Accuracy	± 0.003 Sec		
Repeat Count	0 - 255		
Short / OPP / OCP Test Function - Turbo Mode Available			
Short Time	0.1-10 Sec / Cont. w Turbo mode OFF / 0.1 - 1.0 Sec w Turbo mode ON		
OPP / OCP Step Time	100 ms w Turbo mode OFF / 100 ms up to 10 steps w Turbo mode ON		

4.4 Protection Modes

MODEL	3C018-18	3C028-18-EV	3C028-28	3C038-28-EV	3C038-38
PROTECTION					
Over Power (OP)	1968.75 VA / W programmable	2940 VA / W programmable	3937.5 VA / W programmable	7875 VA / W programmable	11812.5 VA/W programmable
Over Current (OC)	19.687 Arms programmable	29.4 Arms programmable	39.375 Arms programmable	78.75 Arms programmable	118.25 Arms programmable
Over Voltage (OV)	367.5 Vrms / 525 Vdc	504 Vrms / 735 Vdc	367.5 Vrms / 525 Vdc	504 Vrms / 735 Vdc	367.5 Vrms / 525 Vdc
	367.5 Vrms / 525 Vdc				
Over Temperature (OT)	Yes				

MODEL	3C056-56	3C075-75	3C112-112
PROTECTION			
Over Power (OP)	5880 VA / W programmable	7875 VA / W programmable	11812.5 VA/W programmable
Over Current (OC)	58.8 Arms programmable	78.75 Arms programmable	118.25 Arms programmable
Over Voltage (OV)	367.5 Vrms / 525 Vdc		
Over Temperature (OT)	Yes		

MODEL	3C150-112	3C188-112	3C225-112
PROTECTION			
Over Power (OP)	15750 VA / W programmable	19688 VA / W programmable	23625.5 VA/W programmable
Over Current (OC)	118.25 Arms programmable	118.25 Arms programmable	118.25 Arms programmable
Over Voltage (OV)	367.5 Vrms / 525 Vdc		
Over Temperature (OT)	Yes		

4.5 Power Factor & Crest Factor Range

MODEL	All Models
CREST / POWER FACTOR RANGE	
Range	CF: √2 to 5.0 / PF: 0.00 to 1.00 Leading or Lagging
Resolution	CF: 0.1 / PF: 0.01
Accuracy	CF: (0.5% / Irms) + 1.0% F.S. / PF: 1.0% F.S.

4.6 Metering

MODEL	3C018-18	3C028-18-EV	3C028-28	3C038-28-EV	3C038-38
METERING					
Voltage Range	0 - 500 V	0 - 700 V	0 - 500 V	0 - 700 V	0 - 500 V
Resolution	0.01 V				
Accuracy	± (0.05% SETTING + 0.05% RANGE)				
Parameters	Vrms, V Max, V Min, ± Vpeak				
Current Ranges (A)	0-9.375	0-18.75	0-9.375	0-18.75	0-37.5
Resolution (mA)	0.2	0.4	0.2	0.4	0.8
Accuracy	50Hz & 60Hz: ± (0.05% READING + 0.05% RANGE) > 60 Hz: ± (0.2% READING + 0.2% RANGE)				
Parameters	Irms, I Max, I Min, ± Ipeak				
Power Range	0 - 1875 W	0 - 2800 W	0 - 2800 W	0 - 3750 W	0 - 3750 W
Resolution	0.03125 W	0.0467 W	0.0467 W	0.0625 W	0.0625 W
Accuracy	± (0.1% OF READING + 0.1% RANGE)				
Apparent Power VA	Vrms x Irms				
Power Factor Range	± 0.000 - 1.000				
Accuracy	± (0.002 + (0.001/PF) * F)				
Frequency Range	DC, 40 - 8 Hz				
Accuracy	± 0.1 %				
Other Measurements	VA, VAR, CF_I, Ipeak, Imax, Imin, Vmax, Vmin, IHD, VHD, ITHD, VTHD				

MODEL	3C056-56	3C075-75	3C112-112
METERING			
Voltage Range	0 - 500 V		
Resolution	0.01 V		
Accuracy	± (0.05% SETTING + 0.05% RANGE)		
Parameters	Vrms, V Max, V Min, ± Vpeak		
Current Ranges	0-28.0 A	0-56.0 A	0-112.5 A
Resolution	0.6 mA	1.0 mA	2.4 mA
Accuracy	50Hz & 60Hz: ± (0.05% READING + 0.05% RANGE) > 60 Hz: ± (0.2% READING + 0.2% RANGE)		
Parameters	Irms, I Max, I Min, ± Ipeak		
Power Range	0 - 5600 W	0 - 7500 W	0 - 11250 W
Resolution	0.1 W	0.125 W	0.1875 W
Accuracy	± (0.1% OF READING + 0.1% RANGE)		
Apparent Power VA	Vrms x Irms		
Power Factor Range	± 0.000 - 1.000		
Accuracy	± (0.002 + (0.001/PF) * F)		
Frequency Range	DC, 40 - 440 Hz, 440 - 800 Hz		
Accuracy	< 440 Hz ± 0.1 % / > 440 HZ ± 0.2%		
Other Measurements	VA, VAR, CF_I, Ipeak, Imax, Imin, Vmax, Vmin, IHD, VHD, ITHD, VTHD		

MODEL	3C150-112	3C188-112	3C225-112
METERING			
Voltage Range	0 - 500 V		
Resolution	0.01 V		
Accuracy	± (0.05% SETTING + 0.05% RANGE)		
Parameters	Vrms, V Max, V Min, ± Vpeak		
Current Ranges	0-56.25 A /0-112.5 A		
Resolution	1.2 mA / 2.4 mA		
Accuracy	50Hz & 60Hz: ± (0.05% READING + 0.05% RANGE) > 60 Hz: ± (0.2% READING + 0.2% RANGE)		
Parameters	Irms, I Max, I Min, ± Ipeak		
Power Range	0 - 15000 W	0 - 18750 W	0 - 22500 W
Resolution	0.25 W	0.3125 W	0.3750 W
Accuracy	± (0.1% OF READING + 0.1% RANGE)		
Apparent Power VA	Vrms x Irms		
Power Factor Range	± 0.000 - 1.000		
Accuracy	± (0.002 + (0.001/PF) * F)		
Frequency Range	DC, 40 - 440 Hz, 440 - 800 Hz		
Accuracy	< 440 Hz ± 0.1 % / > 440 HZ ±0.2%		
Other Measurements	VA, VAR, CF_I, Ipeak, Imax, Imin, Vmax, Vmin, IHD, VHD, ITHD, VTHD		

4.7 Other Specifications

MODEL	3C018-18	3C028-18-EV	3C028-28	3C038-28-EV	3C038-38
OTHER SPECIFICATIONS					
MASTER / SLAVE 3 PHASE	Yes				
External Programming Input	0 - 10 Vdc for Full Scale, Resolution 0.1V				
External Sync Input	TTL				
V Monitor Out (Isolated)	± 500V / ± 10V, Latency = 30 ~ 50 µsec				
I Monitor Out (Isolated) Latency = 30 ~ 50 µsec	± 56.25 Apeak ± 10 Vpeak	± 56.25 Apeak ± 10 Vpeak	± 84 Apeak ± 10 Vpeak	± 84 Apeak ± 10 Vpeak	± 112.5 Apeak ± 10 Vpeak
Interface Options	LAN, USB, RS232, GPIB (select one)				

MODEL	3C056-56	3C075-75	3C0112-112
OTHER SPECIFICATIONS			
MASTER / SLAVE 3 PHASE	Yes		
External Programming Input	0 - 10 Vdc for Full Scale, Resolution 0.1V		
External Sync Input	TTL		
V Monitor Out (Isolated)	± 500V / ± 10V		
I Monitor Out (Isolated)	± 168 Apeak ± 10 Vpeak	± 225 Apeak ± 10 Vpeak	± 337.5 Apeak ± 10 Vpeak
Interface Options	LAN, USB, RS232, GPIB (select one)		

MODEL	3C150-112	3C188-112	3C225-112
OTHER SPECIFICATIONS			
MASTER / SLAVE 3 PHASE	Yes		
External Programming Input	0 - 10 Vdc for Full Scale, Resolution 0.1V		
External Sync Input	TTL		
V Monitor Out (Isolated)	± 500V / ± 10V		

MODEL	3C150-112	3C188-112	3C225-112
I Monitor Out (Isolated)		± 337.5 Apeak ± 10 Vpeak	
Interface Options	LAN, USB, RS232, GPIB (select one)		

4.8 AC Input, Cooling, Dimensions, Weights

MODEL	3C018-18	3C028-18-EV	3C028-28	3C038-28-EV	3C038-38
GENERAL					
AC Input	100 - 230 Vac ±10%, 50/60 Hz ± 3 Hz				
Max Power Consumption	150 VA				
Protection Fuse	T2A / 250V (5 * 20 mm)				
Cooling	Variable speed fan, front air intake, rear exhaust				
Dimensions (H x D x W)	177 x 440 x 513 mm / 7" x 17.32" x 20.2"				
Weight (Net)	21.5 kg / 47.4 lbs	21.5 kg / 47.4 lbs	27.5 kg / 60.6 lbs	27.5 kg / 60.6 lbs	33.5 kg / 73.9 lbs
Operating Temperature	0 - 40° C / 32 - 104° F				
Relative Humidity	80% Max., non-condensing				
Environment	Indoor Use Only. Pollution Degree 2				
Altitude	2000 meters/ 6550 feet				
EMC & Safety	CE Mark				

MODEL	3C056-56	3C075-75	3C0112-112
GENERAL			
AC Input	100 - 230 Vac ±10%, 50/60 Hz		
Max Power Consumption	150 VA		
Protection Fuse	T2A / 250V (5 * 20 mm)		
Cooling	Variable speed fan, front air intake, rear exhaust		
Dimensions (H x D x W)	458x480x593mm 18"x18.9"x23.4"	458x480x593mm 18"x18.9"x23.4"	636x480x593mm 25"x18.9"x23.4"
Weight (Net)	70 kg / 154.3 lbs	70 kg / 154.3 lbs	105 kg / 231.5 lbs
Operating Temperature	0 - 40° C / 32 - 104° F		
Relative Humidity	80% Max., non-condensing		
Environment	Indoor Use Only. Pollution Degree 2		
Altitude	2000 meters/ 6550 feet		
EMC & Safety	CE Mark		

MODEL	3C150-112	3C188-112	3C225-112
GENERAL			
AC Input	100 - 230 Vac ±10%, 50/60 Hz		
Max Power Consumption	150 VA		
Protection Fuse	T2A / 250V (5 * 20 mm)		
Cooling	Variable speed fan, front air intake, rear exhaust		
Dimensions (H x D x W)	813 x 480 x 593 mm 32.0" x 18.9" x 23.4"	990 x 480 x 593 mm 39.0" x 18.9" x 23.4"	1168 x 480 x 593 mm 46.0" x 18.9" x 23.4"
Weight (Net)	138.5 kg / 305.3 lbs	172 kg / 379.2 lbs	205.5 kg / 453.0 lbs
Operating Temperature	0 - 40° C / 32 - 104° F		
Relative Humidity	80% Max., non-condensing		
Environment	Indoor Use Only. Pollution Degree 2		
Altitude	2000 meters/ 6550 feet		
EMC & Safety	CE Mark		

4.9 Control Interfaces

MODEL	All Models
CONTROL INTERFACE	
Options	USB, LAN, GPIB or RS232
Only one interface can be installed per unit.	

Notes:

1. mS (milliSiemens) is the unit of conductance(G), one Siemens equals $1/\Omega$
2. Operating temperature range is 0~40°C, all specification apply for 25°C±5°C, Except as noted
3. Specifications subject to change without notice.

4.10 Voltage versus Current Operating Envelope Charts

Following charts show constant power operating envelopes for each load model. Operation below the low voltage level is not possible as the load will turn off if insufficient input voltage is sensed.

4.10.1 Model 3C018-18 V-I Curve

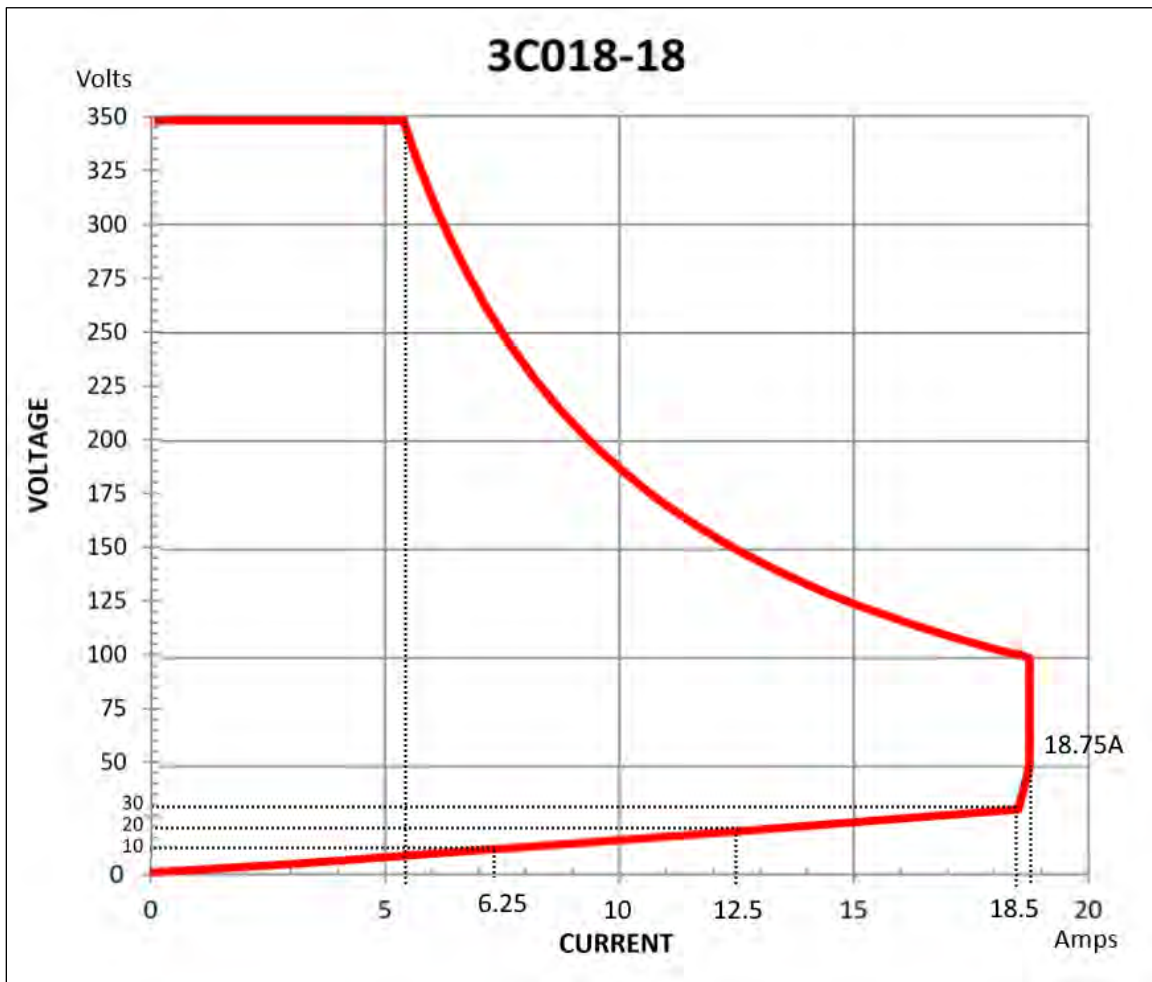

Figure 4-1: Model 3C018-18 V-I Curve

4.10.2 Model 3C028-18-EV V-I Curve

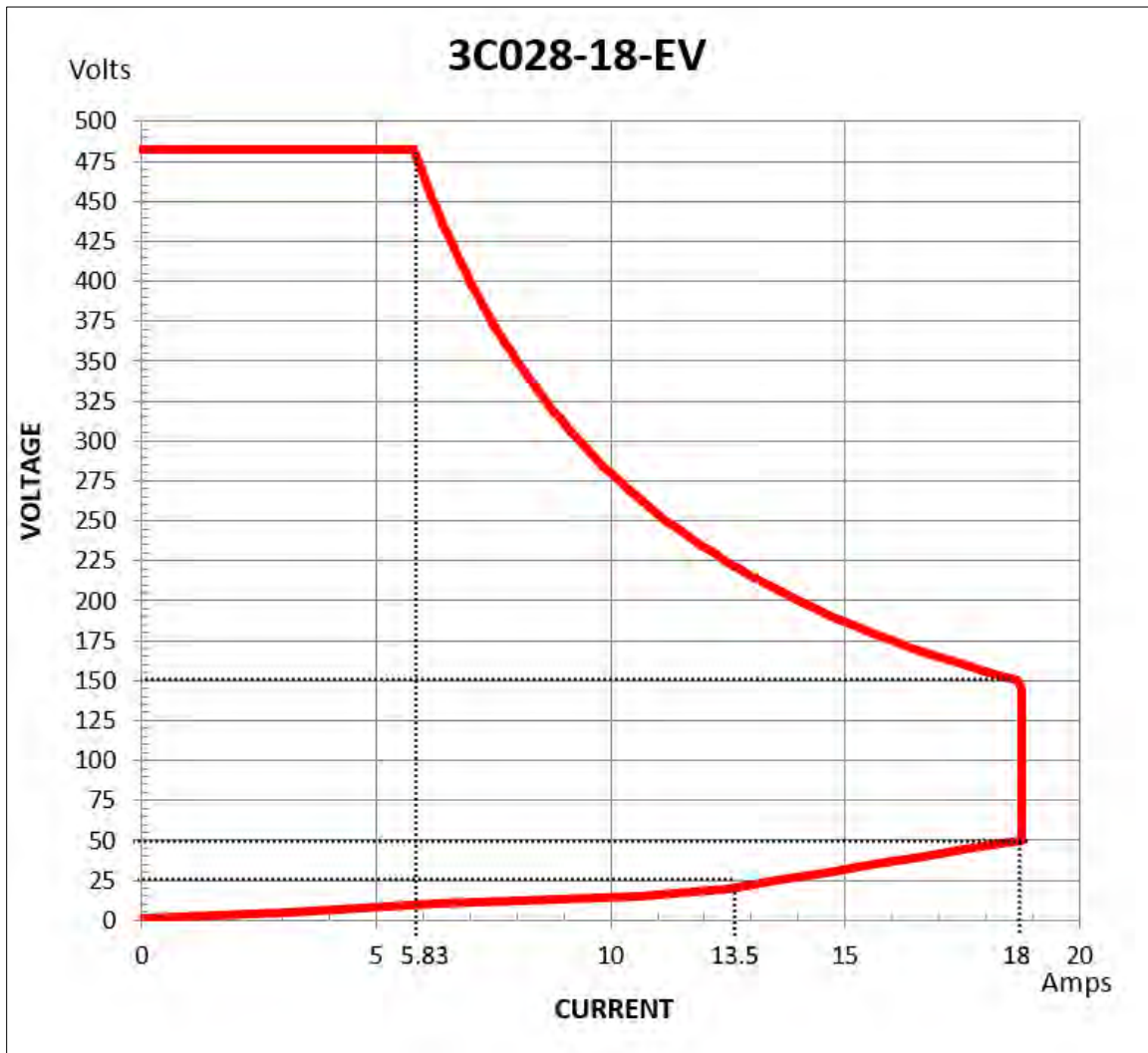

Figure 4-2: Model 3C028-18-EV V-I Curve

4.10.3 Model 3C028-28 V-I Curve

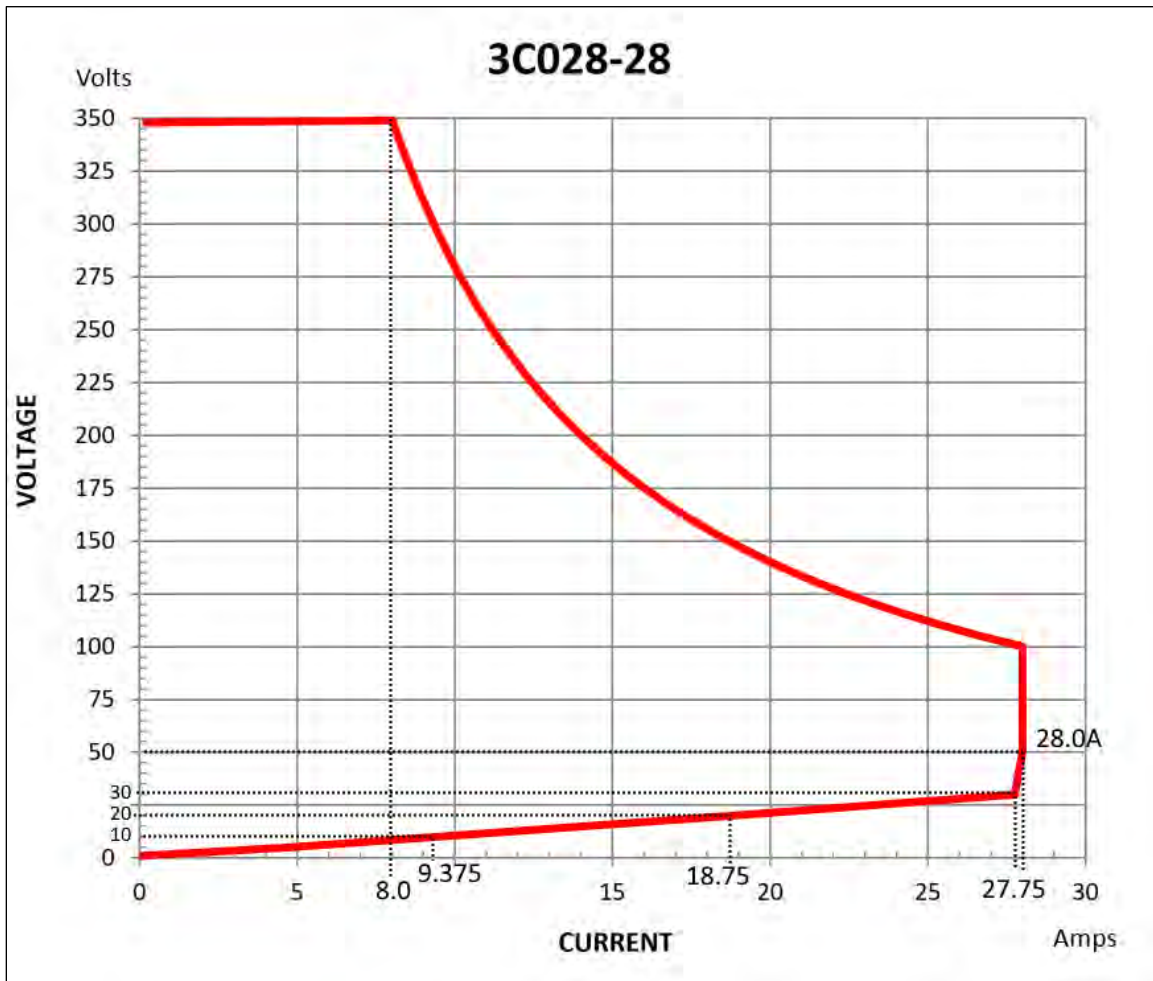

Figure 4-3: Model 3C028-28 V-I Curve

4.10.4 Model 3C038-28-EV V-I Curve

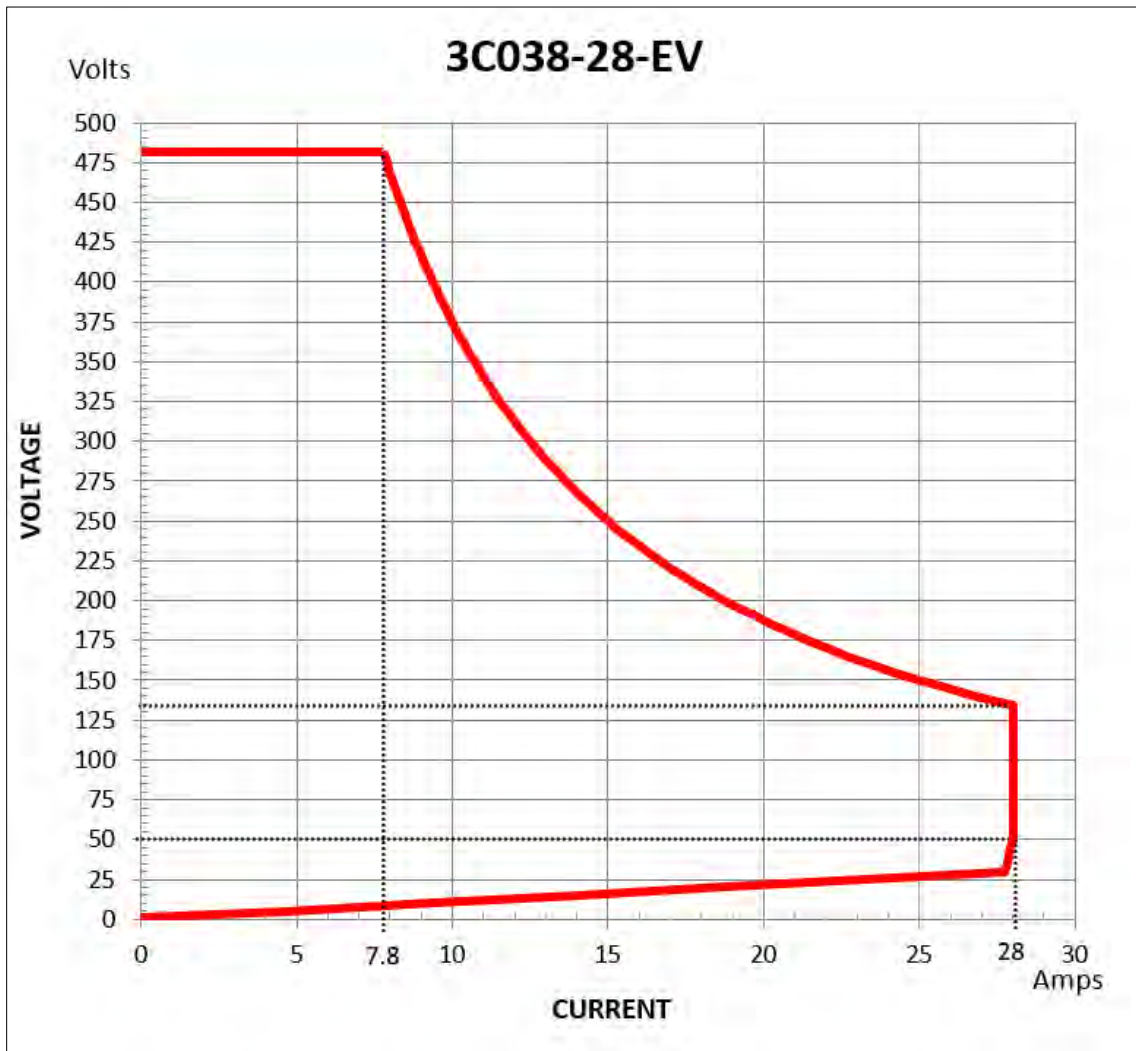

Figure 4-4: Model 3C038-28-EV V-I Curve

4.10.5 Model 3C038-38 V-I Curve

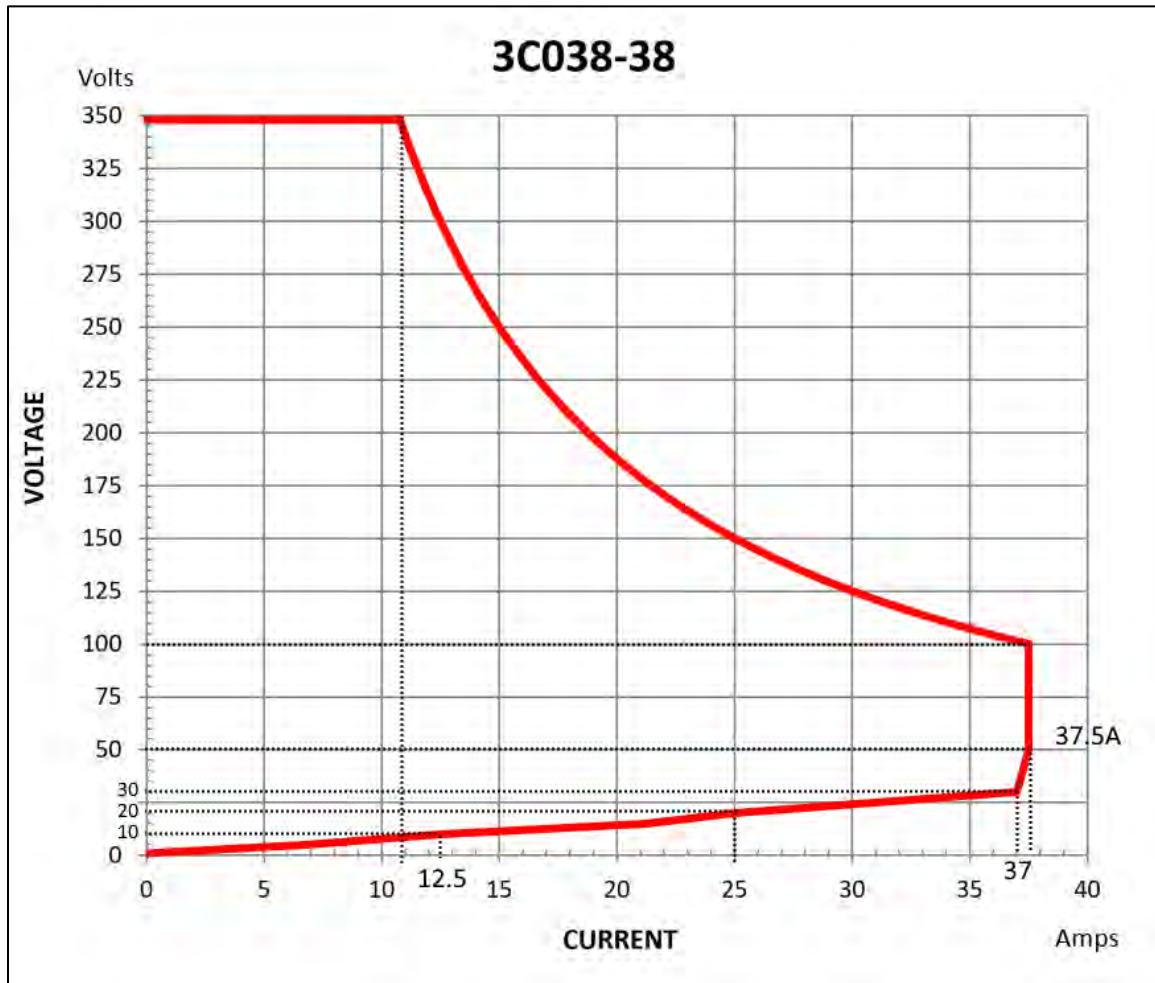

Figure 4-5: Model 3C038-38 V-I Curve

4.10.6 Model 3C056-56 V-I Curve

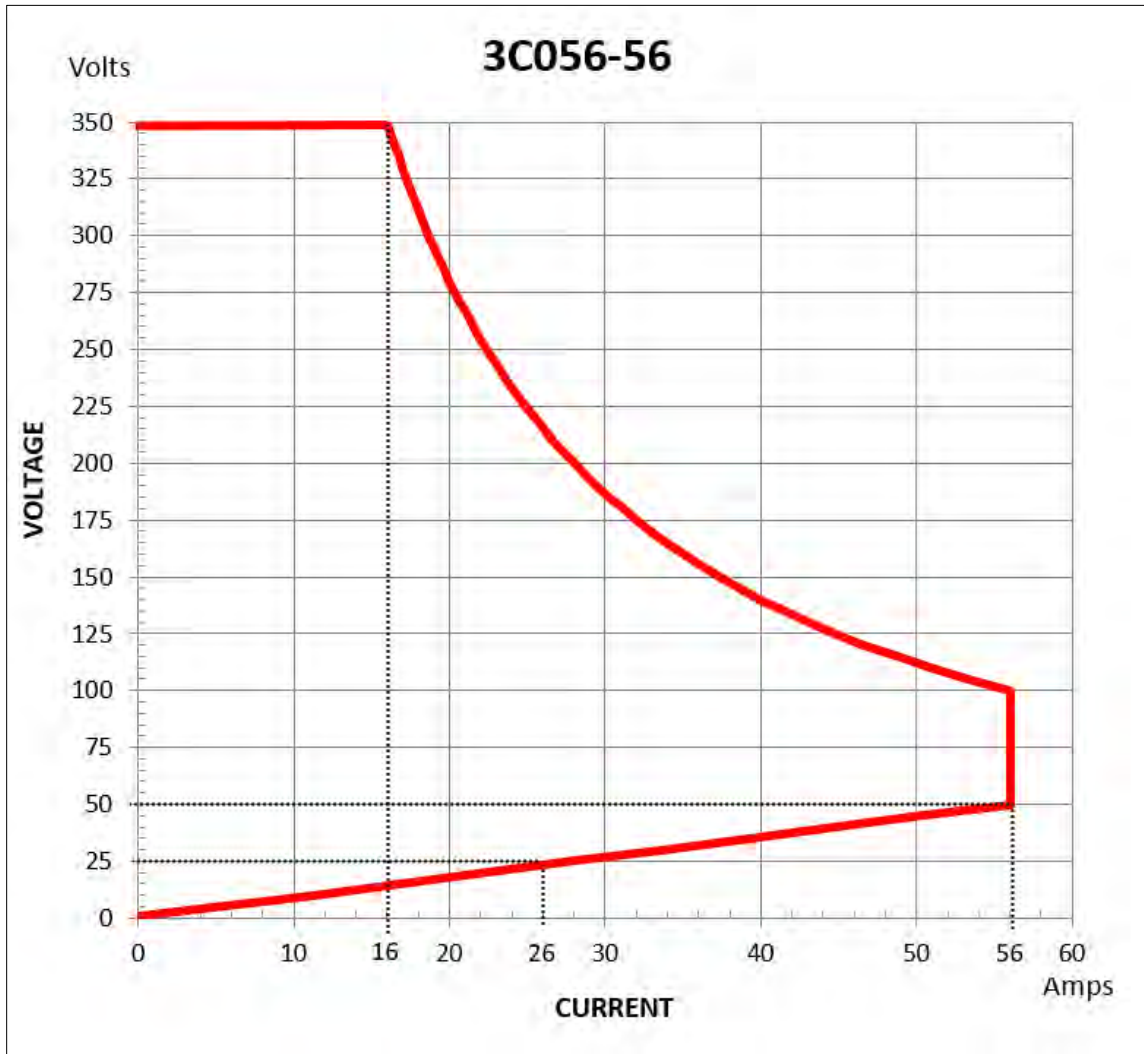

Figure 4-6: Model 3C056-56 V-I Curve

4.10.7 Model 3C075-75 V-I Curve



Figure 4-7: Model 3C075-75 V-I Curve

4.10.8 Model 3C112-112 V-I Curve

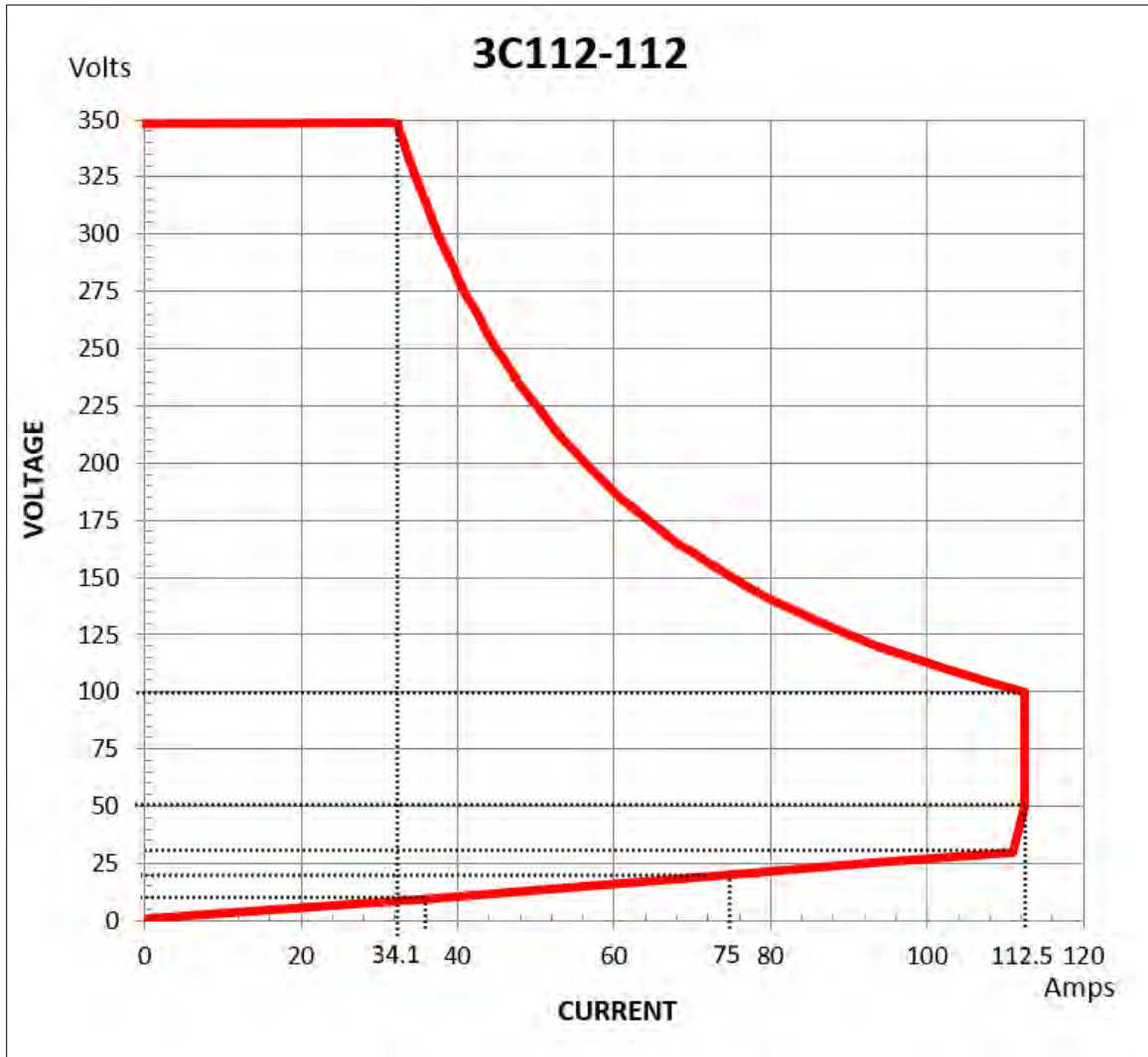

Figure 4-8: Model 3C112-112 V-I Curve

4.10.9 Model 3C150-112 V-I Curve

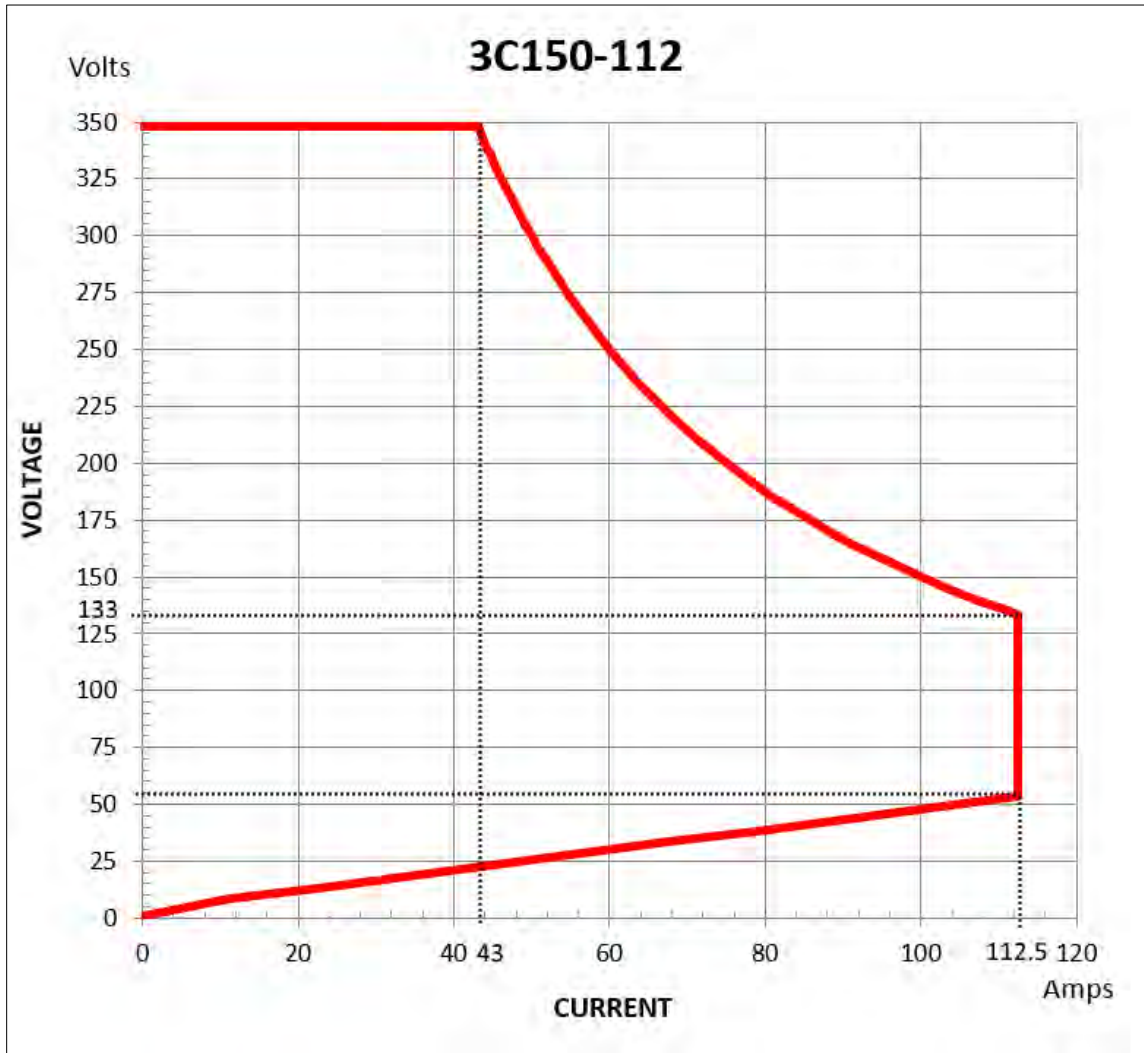

Figure 4-9: Model 3C150-112 V-I Curve

4.10.10 Model 3C188-112 V-I Curve

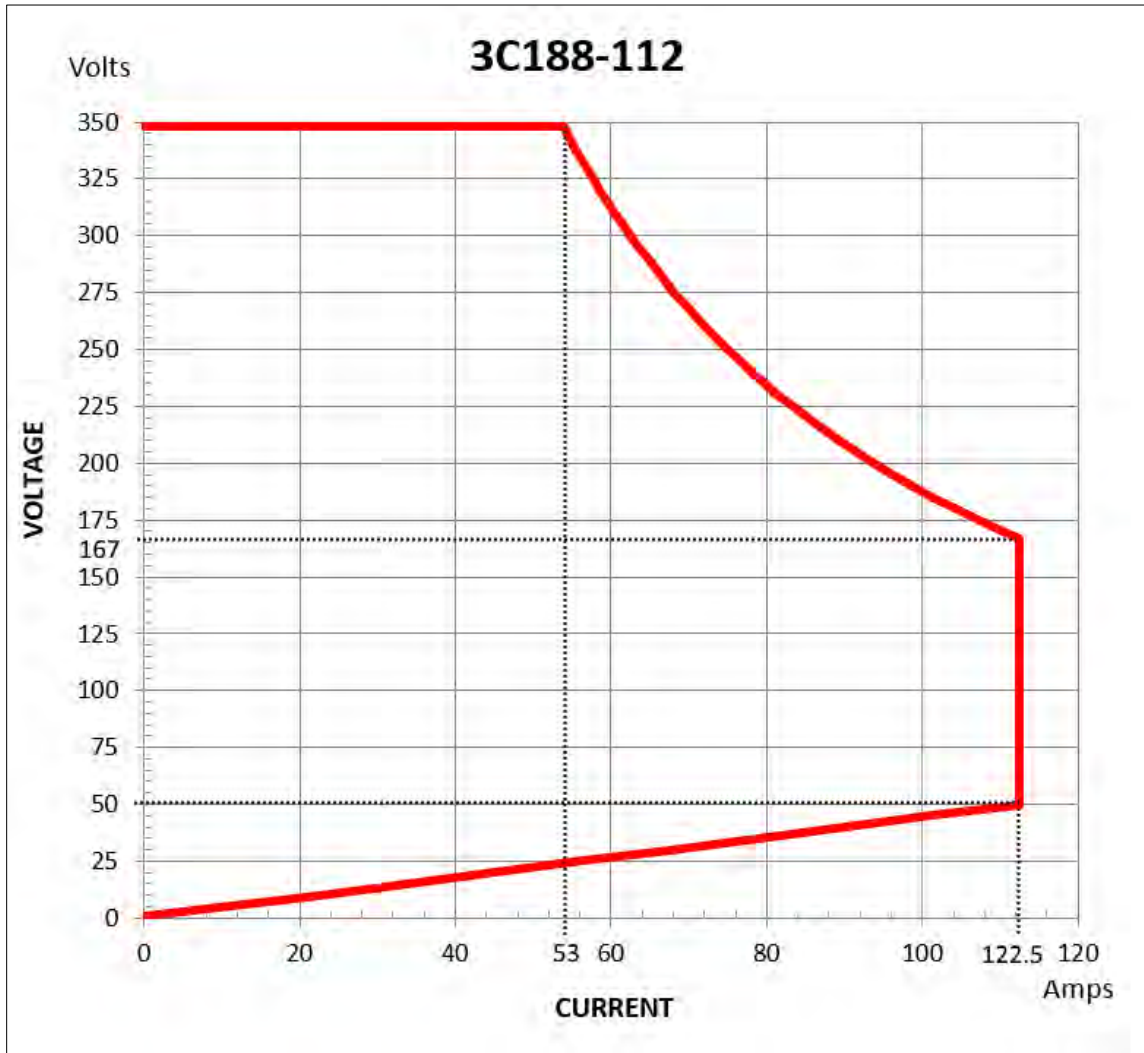

Figure 4-10: Model 3C188-112 V-I Curve

4.10.11 Model 3C225-112 V-I Curve

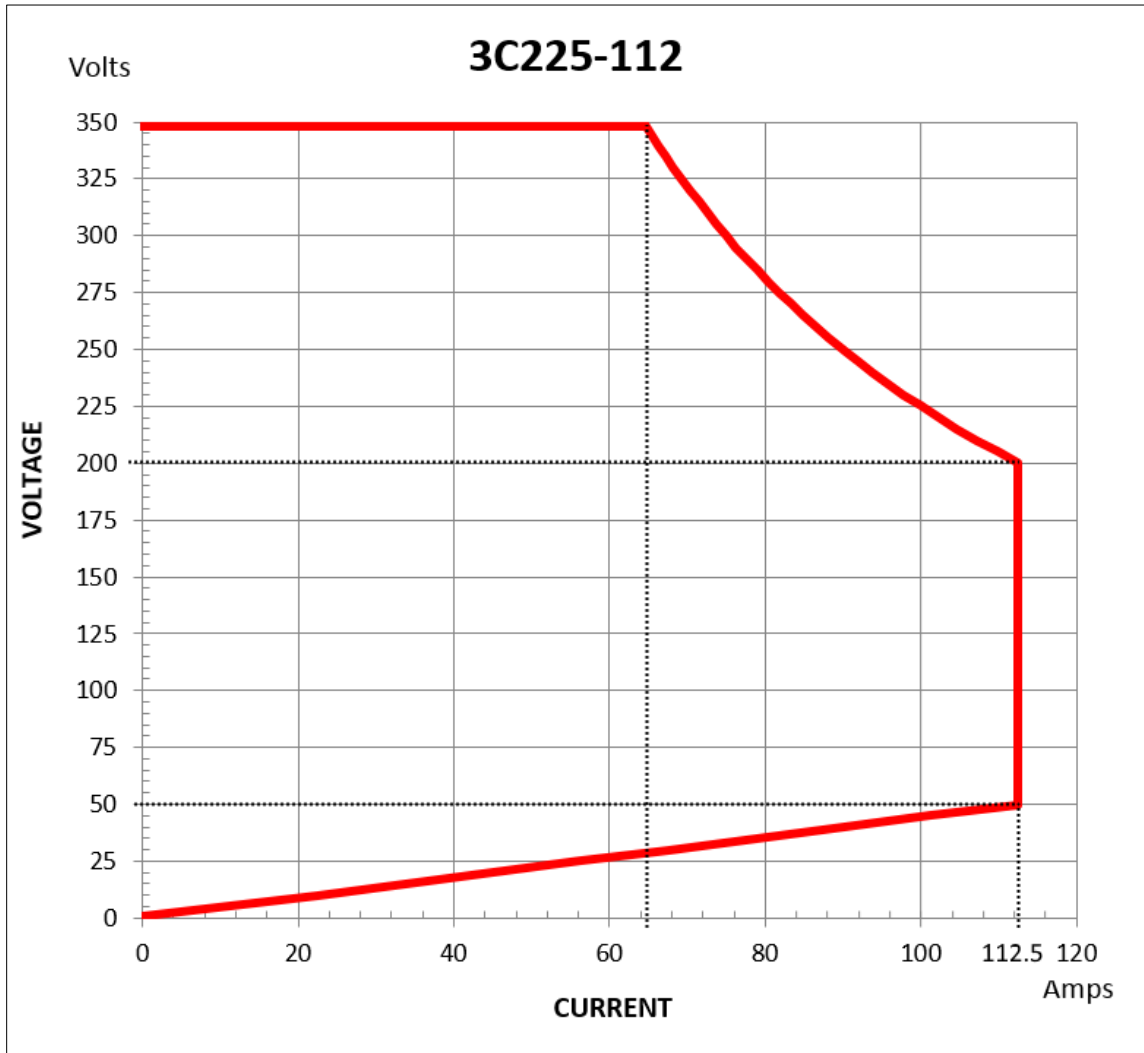

Figure 4-11: Model 3C225-112 V-I Curve

5 Unpacking and Installation

5.1 Inspection

The 3C Series AC & DC loads are carefully inspected before shipment. If instrument damage has occurred during transport, please inform Adaptive Power Systems' nearest sales and service office or representative.

Your 3C Series High Power Electronic Load was shipped with a power cord for the type of outlet used at your location. If the appropriated cord was not included, please contact your nearest Adaptive Power Systems sales office to obtain the correct cord. Refer to rating label on the back of the unit to check the line voltage selection and fuse type.

5.2 Ship Kit

Remove the ship kit from the box. The load is supplied with a ship kit that contains the following items. See Section 3.7, "Accessories Included" on page 47 for more details.

Item	Quantity
Operation Manual in hardcopy or PDF Format (Download at https://tr.adaptivepower.com/ Note: Registration is required to access technical resources.	1
AC Line Cord	1
Rack Handles (detachable)	2
Round Terminal RVL1-4	2
Round Terminal RNYBS8-4	2
Terminal PTV1-12	6
HD DSUB 15 pin Male to Male, 150 cm / 59"	1
Certificate of Conformance	1

Table 5-1: 3C Series AC+DC Load Ship Kit Content

5.3 Check Line Voltage

The 3C load can be operated with any AC input voltage from 100Vac to 230Vac as indicated on the label on the rear panel. Make sure that the line voltage at the location of the load falls within this range.

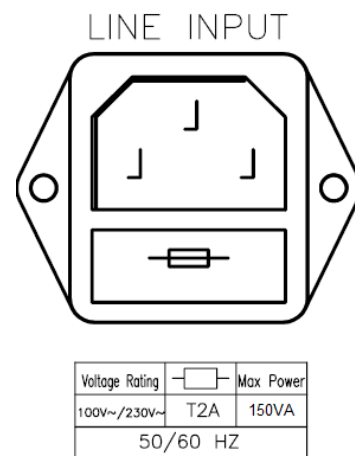
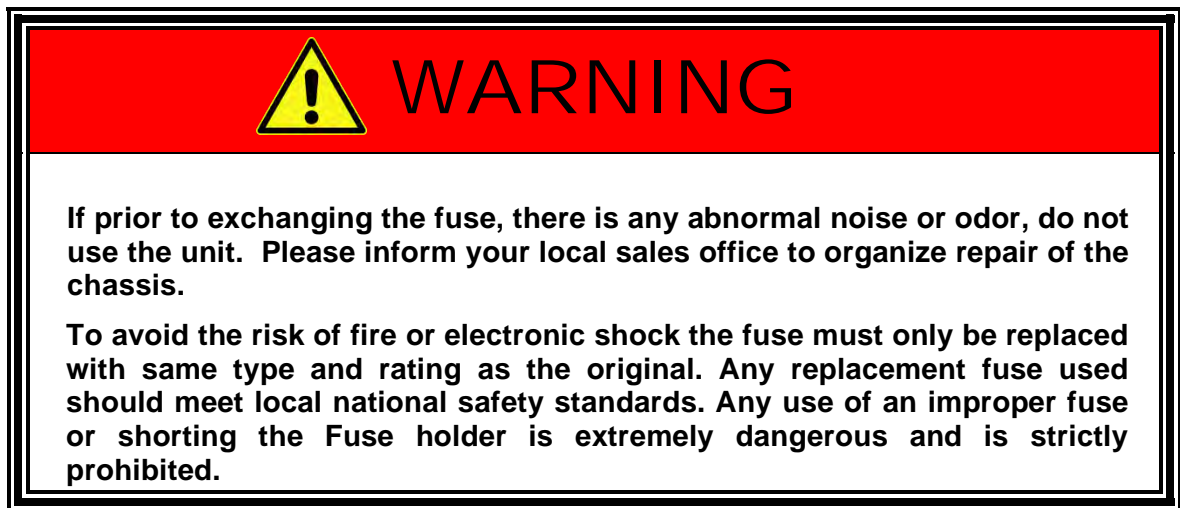
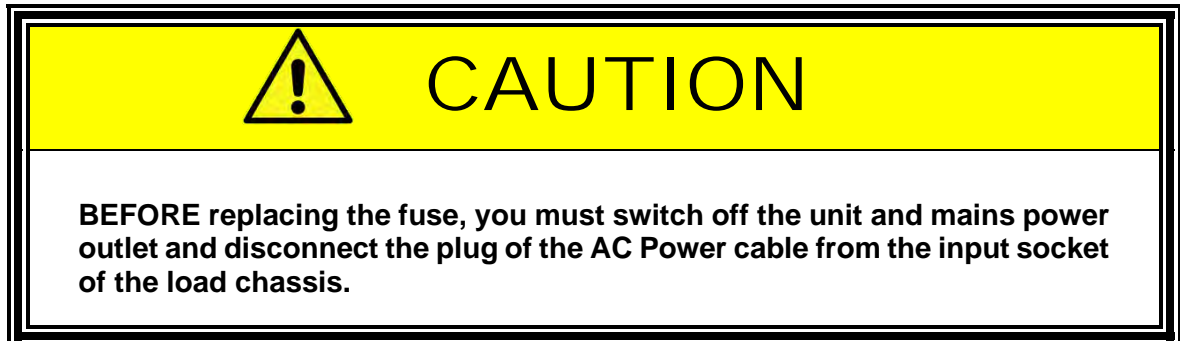

Figure 5-1: AC Input Voltage Label

5.4 Input Fuse

This product is fitted with a mains input fuse. If it needs to be replaced, please adhere to the following procedure.



5.4.1 Fuse Replacement Procedure

To replace the AC line input fuse, proceed as follows:

1. Check the rating of the mains input fuse. Replace only with the correct type and rating. T2A/250V (5*20mm)
2. The AC line fuse is located below the AC line socket (see *Figure 5-2*). Use a small screwdriver to remove the fuse holder. Replace the failed fuse with the appropriate type and rating according to your mains voltage.
3. Refit the fuse holder and connect the power cord.

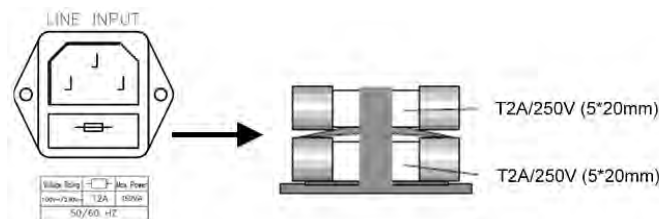

Figure 5-2: AC Line Fuse Holder Location

5.5 Grounding Requirements



The unit is grounded via the AC Input. A line cord with proper Earth Ground pin must be used at all times. Correct grounding of your electrical system infrastructure according to applicable national standards must also be observed.

5.6 Chassis Position

The 3C load chassis is equipped with surface protection feet and tilt stands installed and is ready for used as a bench instrument. The feet provide a good viewing angle for bench-top use.

5.7 Rack Mounting

The 3C load chassis is designed to be rack mounted in a standard 19-inch rack for system applications. If needed, the feet and tilt-stands may be removed to accommodate zero stacking with other test equipment. Rack mount handles and required hardware to install them on the unit are included in the ship kit.

Parallel models 3C056-56, 3C075-75 and 3Cxxx-112 can be rack mounted by removing the casters and installing the included rack mount handles.

5.8 Cleaning

To clean this product uses a soft or slightly damp cloth.

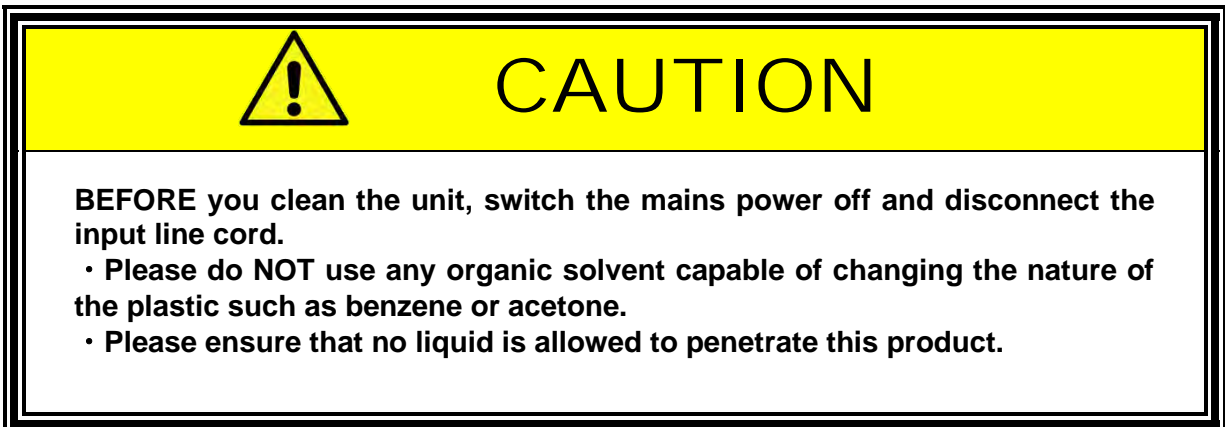

5.9 Powering Up

The following procedure should be followed before applying mains power:

1. Check that the POWER switch is in the OFF (O) position.
2. Check that nothing is connected to any of the INPUT (load input terminals) at the rear panel.
3. Verify that the line voltage is within the AC input range shown below the IEC13 inlet connector.
4. Connect the correct AC mains line cord to the load's AC input socket.
5. Plug the line cord plug into a suitable AC outlet socket.
6. Turn on (I) the POWER switch.
7. If the instrument does not turn on for some reason, turn OFF the POWER switch and verify the presence of the correct AC line input voltage using appropriate safety measures.

5.10 In Case of Malfunction

In the unlikely event of an instrument malfunction or if the load does not function, please attach a warning tag to the instrument to identify the owner and indicate that service or repair is required. Contact Adaptive Power Systems or its authorized representative to arrange for service.

5.11 Load Connection

WARNING

DO NOT EXCEED LOAD INPUT VOLTAGE RATING

This instrument does **NOT** have a means to disconnect its Load input from a connected power supply. If the voltage applied to the Load input exceeds its maximum rating – even if the load is turned completely off – damage to the load **WILL** occur. Damage caused by exceeded maximum load input voltage under any circumstance is **NOT** covered by the manufacturer’s product warranty. Remove any load input connections when the load is not in use, even when it is turned off.

When setting up for a new test and connecting any equipment to the AC & DC load, proceed as follows:

1. Check that the output of the equipment under test is **OFF**.
Note: Some power equipment’s output may still be energized even if the equipment has been turned off or its output is turned off. This is especially true for DC power supplies.

Note: When working with batteries, it is recommended to provide a suitable disconnect relay or switch so the load connection can be disconnected from the battery for handling purposes.
2. Connect one end of the load wires to the load input terminals jacks on the front panel of the 3C load.
3. Check the polarity of the connections and connect the other end of the load wires to the output terminal of the equipment under test.
4. When connecting multiple 3C loads to the same EUT, makes sure the load wire lengths to each load are the same.

5.12 Remote Control Interfaces

The 3C Series load supports one of four optional interfaces. They are:

- USB -USB Option
- LAN -LAN Option
- RS232 -RS232 Option
- GPIB -GPIB Option

5.12.1 GPIB Interface

The GPIB Option connector when installed is located on the rear panel of the load. This connector allows the load mainframe to be connected to a PC with GPIB controller and other GPIB devices. A GPIB system can be connected in any configuration (star, linear, or both) as long as the following conditions are met:

- The maximum number of devices including the controller is equal or less than 15.
- The maximum length of the GPIB cable is no more than 2 meters.
- The total lead length of all devices connected together totals less than 20 meters.
- Please make sure the lock screws are firmly hand-tightened, use a screwdriver only for the removal of screws. Figure 5-3 shows the rear panel of the 3C Series load. The GPIB address of the load is set from the front panel.



Figure 5-3: 3C Series Chassis Rear Panel – GPIB Option Location

The GPIB Address can be set from the front panel.

5.12.2 USB, LAN or RS232 Interfaces

Other interface options are installed in the same position as the GPIB option shown in Figure 5-3.

5.13 Analog I/O Connections

All analog I/O connections are made at the rear panel using the green compression terminal block.

5.13.1 Analog Terminal Block

This connector provides two analog differential inputs and two isolated outputs:

- I Monitor Load Current Monitor Output signal (Latency = 30 ~ 50 μ sec)
- V Monitor Load Voltage Monitor Output signal (Latency = 30 ~ 50 μ sec)
- Analog Input Programming Input
- Sync Input Synchronization Input

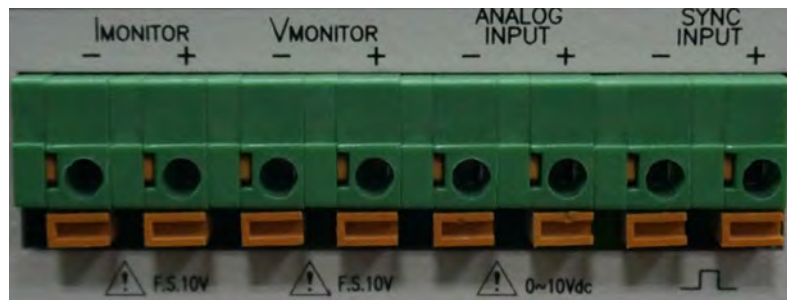
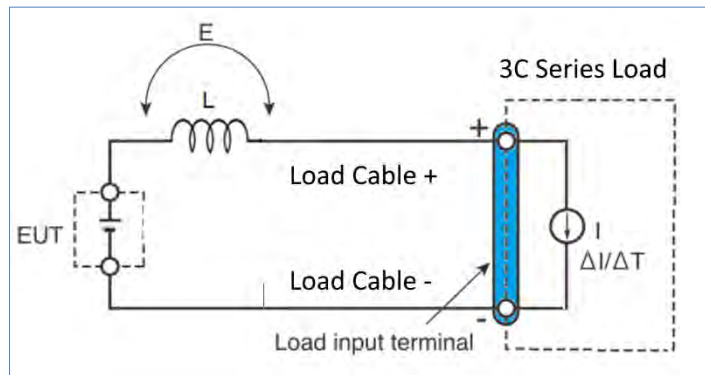

Figure 5-4: Analog I/O Connector

5.13.2 Load Wire Inductance Considerations

The load input wiring has a certain amount of inductance (L). When the load current (I) varies over a short time period, it induces a large voltage at both ends of the load cable. This voltage applies to all of the load input terminals of the 3C Series load when the output impedance of the EUT is relatively small. The voltage generated by the load wire inductance (L) and the current variation (I) is expressed by the following equation:



$$E = L \times (\Delta I / \Delta T)$$

E: Voltage generated by the wire inductance

L: Load wire inductance

ΔI : Amount of Current variation

ΔT : Variation period of current

In general, the wire inductance can be measured approximately $1 \mu\text{H}$ per 1 meter. If 10 meters of Load wires are connected between the EUT and the electronic load, with a current variation of $2 \text{ A}/\mu\text{s}$, the voltage generated by the wire inductance will be 20 V.

The negative polarity of the load input terminal is the reference potential of an external control signal. Therefore, any device or instrument connected to the external control input terminal may malfunction or sustain damage.

When operating in constant voltage (CV) mode, constant resistance (CR) mode or constant power (CP), the load current is controlled by the voltage at the load input terminal. Thus, the operation of the load can be affected by the generated voltage in the load cabling.

For this reason, it is strongly recommended to twist the wiring to the EUT and keep the wire lengths as short as possible.



CAUTION

If the load wires are long or have a large loop, the wire inductance will increase. Consequently, the current variation that results when switching occurs will cause a larger voltage drop.

When the value of the instantaneous load input voltage drops below the minimum operating voltage V-OFF, the response and recovery to a voltage change will be extensively delayed.

In such an event, the electronic load may generate unstable oscillations. In this unstable condition, the input voltage may exceed the maximum rated input voltage and cause damage to the load.

This is illustrated in the two figures below.

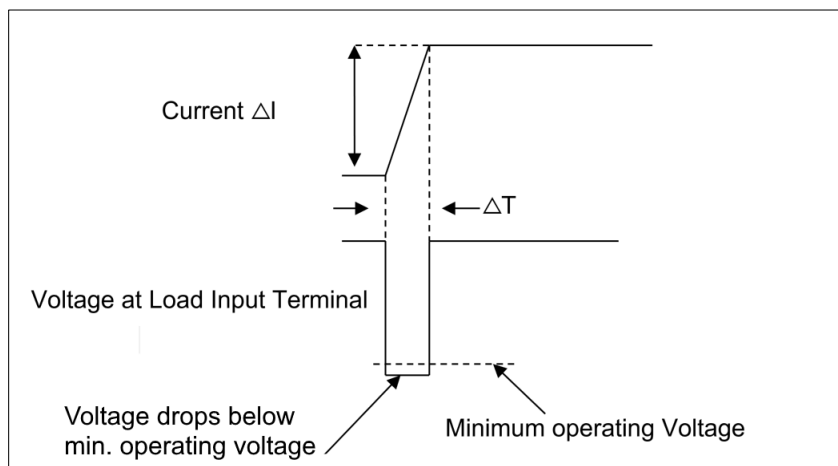

Figure 5-5: Cable induced input voltage drop

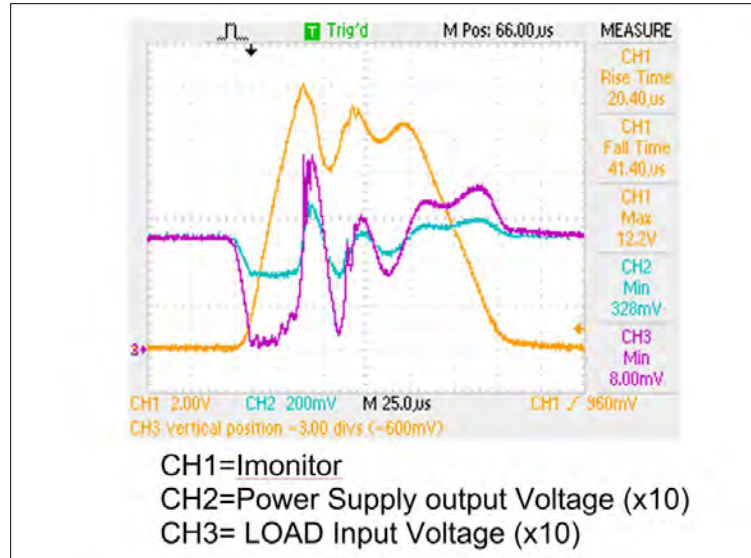

Figure 5-6: Unstable condition waveform capture example

To prevent such problems, connect the load and the equipment under test together using the shortest possible twisted wire to keep the voltage caused by inductance between the minimum operating voltage and the maximum input voltage range or set the current slew rate slower.

If the high-speed response operation is not required, decrease the slew rate setting. With these settings, the value of DI / DT will be decreased and, accordingly the generated voltage on the load cables will be reduced, even if the inductance of load wiring cannot be reduced.

For the case of DC mode operation, the phase delay of the DC current may cause instability in the load, also inducing oscillation. Use the same cable twist and length precautions in DC mode.

If only DC operation is required, connect a capacitor to the load's input terminal as shown in to alleviate any oscillation. Use a capacitor rating that supports any DC ripple current.

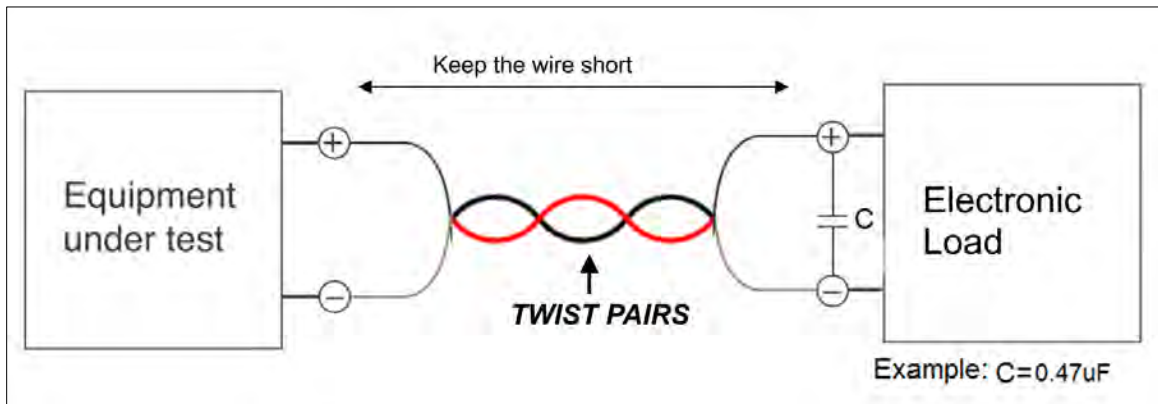

Figure 5-7: Load Cable Length and Twisted Pairs

6 Front Panel Operation

This Chapter provides an overview of front panel operation for the 3C Series AC & DC loads. For remote control operation, refer to Section 8, “Remote Control Programming” on page 109 of this manual for an overview of available programming commands.

6.1 Introduction

Figure 6-1 below shows the front panel layout. All user controls are to the right of the backlit LCD display.



Figure 6-1: 3C Series Load Front Panel

The following functions and features are programmable using the 3C front panel controls.

- 5-digit V/A/W Meter, display the Voltage (Vrms, Vpeak, Vmax., Vmin), Current (Irms, Ipeak, Imax., Imin.) Watt, Voltampere (VA), Frequency, Crest Factor, Power Factor, Total Harmonic Distortion of Voltage (VTHD), Voltage Harmonics (VH), Total Harmonic Current Distortion (ITHD), Current Harmonics (IH).
- CC, Linear CC, CR, CV, CP, AC Rectifier Load and Turbo mode.
- Up to 3 units in master / slave parallel control mode.
- Three units to test three-phase power supplies using a Δ or Y connection.
- Frequency Range of DC, 40 ~ 800 Hz.
- Adjustable range Crest factor, 1.414~5.0
- Power factor (PF) adjustable range: 0~1 leading or (-1~0) lagging
- External input voltage control for CC, Linear CC, CR, CV and CP modes
- Built-in Test modes: Includes UPS , PV Inverter Efficiency, UPS Back-up time, Battery Discharge time, UPS transfer time, Fuse/Breaker Trip/Non-Trip, Short circuit simulation (with programmable short circuit time), OCP, OPP test functions.
- 150 sets Store/Recall memory
- Protection against W, I (Programmable), V and Temperature

6.2 Front Panel Controls Layout

The front panel contains all displays and controls for the operator to interact with the load. The figure below shows the various sections. The numbered callouts are listed below.

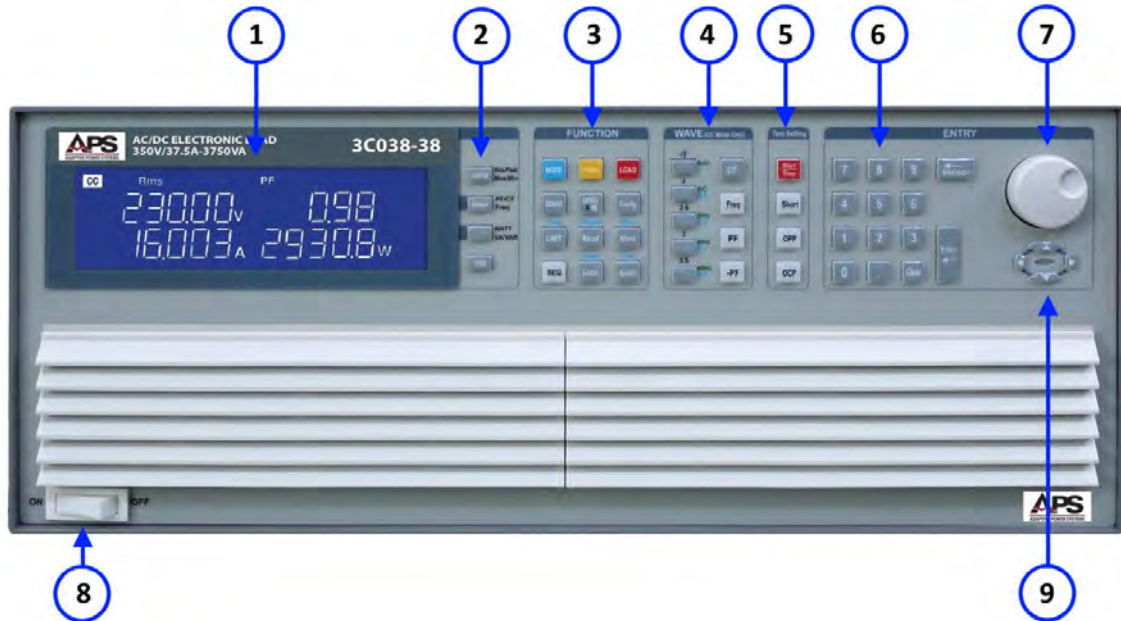

Figure 6-2: Front Panel Display and Controls Call-outs

Call-outs:

1. LCD Display monitor
2. Measurement selection keys
3. FUNCTION Keys
4. WAVE (waveform) Keys
5. TEST FUNTION Keys
6. Numeric Data Entry Keys
7. Shuttle Knob
8. Power ON/OFF button
9. Cursor & Set Keys

6.3 High Brightness LCD Display

The large, high brightness LCD display on the 3C Series load makes it easy to read settings and measurements. There are four large numeric read-out sections and a number of mode and function annunciators.

The various display element are described below.

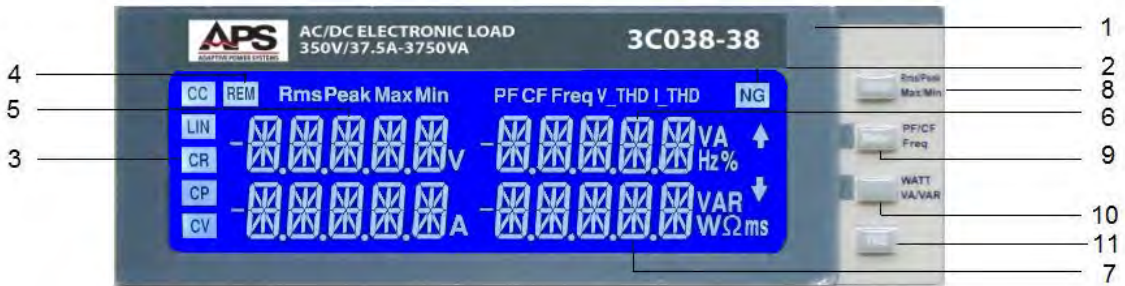

Call-out #	Description
1	3C load 350V/37.5A, 3750W AC/DC Electronic Load Refers to model number, voltage, current and power specification of 3C load Series High Power AC/DC Electronic Load.
2	NG LED Indicator When the reading of Vmeter, Ameter, Wattmeter or VA meter exceeds the upper or lower limit set, this indicator will lit on.
3	MODE Key and LED indicator of CC, LIN, CR, CP, CV On the 3C load Series AC/DC Electronic Load, there are 5 working modes which can be selected by MODE KEY with the sequence of Constant Current, Linear Constant Current, Constant Resistance, Constant Power and Constant Voltage. Then switching can be made in such a sequence. However, LED indicator of CC, LIN, CR, CP and CV will display the working mode selected.
4	REM LED Indicator When 3C AC & DC Electronic Load is connected with computer program for control and operation, REM LED Indicator will come on. In such a case, panel manual operation will become null and void. When REM LED indicator comes off, panel manual operation will resume.

Call-out #	Description
5	<p>This 5 Digits display is a multi-function meter. Its functions are described as follows:</p> <p>Left upper 5 Digits Meter under general conditions: This meter will be a 5 digits voltmeter to display the voltage at the load input terminal or Vsense input terminal. The units is rms, press Rms/Peak/Max/Min key can change the units to peak or maximum or minimum. Under Short test enable and Short setting state this monitor will display "SHORT". Under OCP test enable and OCP setting state, this monitor will display "OCP". Under OPP test enable and OPP setting state, this monitor will display "OPP". Under Non-L, test enable and Non-L setting state this monitor will display "Non-L". Under NL+CR test enable and NL+CR setting state this monitor will display "NL+CR". Under FUSE test enable and FUSE setting state, this monitor will display "FUSE". Under BATT test enable and BATT setting state, this monitor will display "BATT". Under Trans test enable and Trans setting state this monitor will display "Trans". Under Short testing, OCP testing and OPP testing state this monitor will be a 5 digits voltmeter to display the voltage at the load input terminal or Vsense input terminal. When OVP protection activated this monitor will display "OVP".</p> <p>3C load Series Operation Manual 11</p> <p>Left lower 5 Digits Meter under general conditions: This meter will be a 2 range 5 digits Ameter (Auto ranging) to display the load current actually flowing into the electronic load. The units is rms, press Rms/Peak/Max/Min key can change the units to peak or maximum or minimum.</p>

Call-out #	Description
6	<p>This 5-digit display is a multi-function meter. Its functions are described as follows: Right upper 5 Digits Meter under general conditions:</p> <p>This meter will be a 5 digits PF meter to display the Power Factor of the load. Press CF key to display CF setting, Press +PF key and –PF key to display PF setting, Press PF/CF/Freq to change this meter to PF or CF or frequency meter, Press THD key to change this meter to V_THD or I_THD meter.</p> <p>Under setting state conditions: CONFIG : This monitor will display EXTIN OFF, SYNC OFF, LDoff, LDON and BW. When pressing the CONFIG key. Its displaying sequence is follows: EXTIN OFF : To setting external input ON or OFF by UP, Down key or rotary switch. SYNC OFF : To setting synchronous ON or OFF by UP, Down key or rotary switch. LDoff : To setting load off voltage by number key or rotary switch. LDON : To setting load on voltage by number key or rotary switch. BW : To setting bandwidth range by UP, Down key or rotary switch. LIMIT : This monitor will display V_Hi, V_Lo, I_Hi, I_Lo, W_Hi, WLo, VA_Hi, VA_Lo, OPL,OCL and NG</p> <p>When pressing the LIMIT key, the display sequence is as follows: V_Hi : To setting voltage high limit when operating in CC, CR, CP mode. V_Lo : To setting voltage low limit when operating in CC, CR, CP mode. I_Hi : To setting current high limit when operating in CV mode. I_Lo : To setting current low limit when operating in CV mode. W_Hi : To setting power(wattage) high limit when operating in CC, CR, CV mode. W_Lo : To setting power(wattage) low limit when operating in CC, CR, CV mode. VA_Hi : To setting VA high limit when operating in CC, CR, CV mode. VA_Lo : To setting VA low limit when operating in CC, CR, CV mode. OPL : To setting Over Power Limit level by UP, Down, number key or rotary switch. OCL : To setting Over Current Limit level by UP, Down, number key or rotary switch. NG : To setting NG (Good/ No Good judgement)enable or disable by UP, Down or rotary switch.</p> <p>Under Short test enable and Short setting state, this monitor will display “PRESS”. Under OCP test enable and OCP setting state, this monitor will display “PRESS”. Under OPP test enable and OPP setting state, this monitor will display “PRESS”. Under Non-L test enable and Non-L setting state, this monitor will display “PRESS”. Under NL+CR test enable and NL+CR setting state, this monitor will display “PRESS”. Under FUSE test enable and FUSE setting state, this monitor will display “PRESS”. Under BATT test enable and BATT setting state, this monitor will display “PRESS”. Under Trans test enable and Trans setting state, this monitor will display “PRESS”. Under Short testing, OCP testing and OPP testing state, this monitor will be a 5 digits current meter to display the load current actually flowing into the electronic load. Under Wave function setting state this monitor will display CF, frequency, +PF and –PF setting value. When OCP protection activated this monitor will display “OCP”</p>

Call-out #	Description
7	<p>This 5-digit display is a multi-function meter. Its functions are described as follows: Right lower 5 Digits Meter under general conditions:</p> <p>This meter will be a 5 digits Wattmeter to display the wattage of the load. Press WATT/VA/VAR key to change this meter to VA meter or VAR meter.</p> <p>Under Press ON state this monitor will display the preset values of CC, CR, LIN, CP, CV mode.</p> <p>Under Short test enable and Short setting state this monitor will display "START".</p> <p>Under OCP test enable and OCP setting state this monitor will display "START".</p> <p>Under OPP test enable and OPP setting state this monitor will display "START".</p> <p>Under Non-L test enable and Non-L setting state this monitor will display "START".</p> <p>Under NL+CR test enable and NL+CR setting state this monitor will display "START".</p> <p>Under FUSE test enable and FUSE setting state this monitor will display "START".</p> <p>Under BATT test enable and BATT setting state this monitor will display "START".</p> <p>Under Trans test enable and Trans setting state this monitor will display "START".</p>
8	This Rms/Peak/Max/Min key can change the units to RMS, peak, maximum or minimum for Voltmeter and Current meter.
9	This PF/CF/Frequency key can change the PF meter to CF or frequency meter.
10	This Watt/VA/VAR key can change the Wattmeter to VA meter or VAR meter.
11	This THD key can change the PF meter to V_THD meter or I_THD meter, the unit is %.

Table 6-1: Description of Display Readouts

6.1 Function Keypad Description

The FUNCTION keypad is used to determine the operating mode and programmed levels for load operation. The following keys are available.

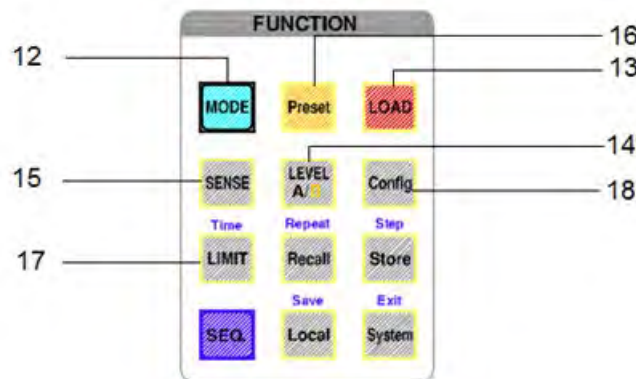

#	sub	Description
12		<p>MODE Key and LED indicator of CC, LIN, CR, CP, CV</p> <p>On the 3C Series AC/DC Electronic Load, there are 5 working modes which can be selected by MODE KEY with the sequence of Constant Current, Linear Constant Current, Constant Resistance, Constant Power and Constant Voltage. Then switching can be made in such a sequence. However, LED indicator of CC, LIN, CR, CP and CV will display the working mode selected.</p>
13		<p>Load ON/OFF key and LED indicator</p> <p>Whether or not the electronic load input terminal of 3C Series electronic load is loaded with current can be controlled by Load ON/OFF Key. Under Load OFF</p>

#	sub	Description
		condition and upon Load ON, the electronic load of 3C Series electronic load will return to the load condition set originally and Load LED is ON indicating that the electronic load is at present under Load ON condition and is ready at any time to be loaded with the load current of the AC/DC input power source.
14		<p>Level A/B Key and LED Monitor</p> <p>Pressing Level Key will be B, press again will be A, further pressing will be B again and so on. B means Level B (LED ON), e.g., to move out Level A, then move in Level B. A means Level A (LED OFF), e.g., to move out Level B, then move in Level A.</p> <p>Under the condition of setting Memory A or B, this key is mainly for setting the values of groups A/B for rapid switching load current or resistance.</p>
15		<p>SENSE ON/OFF Key and LED Indicator</p> <p>The voltmeter and internal trigger circuit of 3C Series electronic load can be controlled by this Key thus determining whether the input to the voltmeter is made from the AC input terminal (OFF) or Vsense terminal (ON). Upon Vsense ON, LED indicator will be ON and the 5-digit voltmeter can display the voltage read from Vsense. Upon Vsense OFF, the 5-digit voltmeter can display the voltage read from AC input terminal.</p>
16		<p>PRES ON/OFF Key and LED Monitor</p> <p>Pressing PRES Key will be ON, pressing again will be OFF, further pressing will be ON again and so on. ON means Preset ON, e.g., to preset condition display to ON. OFF means preset OFF, e.g., the condition is not preset and shall be the actual condition of the voltage and current of the load.</p> <p>Under Preset OFF condition, the left upper 5-digit monitor display the voltage input to electronic load while the right lower 5-digit monitor display the current flowing into electronic load with the unit as "V" & "A" respectively and the unit indicator will come on also.</p> <p>Under Preset ON condition, PRES LED monitor is ON, right lower 5-digit monitor will have different displays with the change of working mode as shown below:</p>
	16.1	<p>C.C. Mode:</p> <p>The setting value of Level A / B load current can be displayed on the right lower 5-digit monitor with the unit as "A", LED indicator will be ON.</p>
	16.2	<p>Linear C.C. Mode:</p> <p>The setting value of Level A / B load current can be displayed on the right lower 5-digit monitor with the unit as "A", LED indicator will be ON.</p>
	16.3	<p>C.R. Mode:</p> <p>The setting value of Level A/B load resistance can be displayed on the right lower 5-digit monitor with the unit as "Ω", LED indicator will be ON.</p>
	16.4	<p>C.P. Mode:</p> <p>The setting value of Level A/B load resistance can be displayed on the right lower 5-digit monitor with the unit as "W", LED indicator will be ON.</p>
	16.5	<p>C.V. Mode:</p> <p>The setting value of Level A/B load resistance can be displayed on the right lower 5-digit monitor with the unit as "V", LED indicator will be ON.</p>

#	sub	Description
17		Limit ON/OFF Key and LED indicator Being pressed, LED will come on and in LIMIT ON condition:
	17.1	The right upper 5-digit monitor display the V Hi and right lower monitor display upper limit of the voltmeter with the unit as "V".
	17.2	The right upper 5-digit monitor display the V Lo and right lower monitor display lower limit of the voltmeter with the unit as "V".
	17.3	The right upper 5-digit monitor display the I Hi and right lower monitor display upper limit of the voltmeter with the unit as "A".
	17.4	The right upper 5-digit monitor display the I Lo and right lower monitor display lower limit of the voltmeter with the unit as "A".
	17.5	The right upper 5-digit monitor display the W Hi and right lower monitor display upper limit of the voltmeter with the unit as "W".
	17.6	The right upper 5-digit monitor display the W Lo and right lower monitor display lower limit of the voltmeter with the unit as "W".
	17.7	The right upper 5-digit monitor display the VA Hi and right lower monitor display upper limit of the voltmeter with the unit as "VA".
	17.8	The right upper 5-digit monitor display the VA Lo and right lower monitor display upper limit of the voltmeter with the unit as "VA".
	17.9	The right upper 5-digit monitor display the OPL and right lower monitor display Over Power Limit of the power with the unit as "W".
	17.10	The right upper 5-digit monitor display the OCL and right lower monitor display Over Current limit of the current meter with the unit as "A".
	17.11	The right upper 5-digit monitor display the NG and right lower monitor display ON or OFF.
18		Config Key and LED indicator Being pressed, LED will come on and in Config setting condition:
	18.1	The right upper 5-digit monitor display the EXTIN and right lower monitor display OFF or ON for external input disable or enable. Default is OFF
	18.2	The right upper 5-digit monitor display the SYNC and right lower monitor display OFF or ON for synchronous from external source disable or enable of rear panel I/O input terminal. Default is OFF.
	18.3	The right upper 5-digit monitor display the LDoff and right lower monitor display load off voltage setting with the unit as "V". The range is 0.01V to 500.00V. Default is 5.00V.
	18.4	The right upper 5-digit monitor display the LDON and right lower monitor display load on voltage setting with the unit as "V". The range is 0.01V to 500.00V. Default is 10.00V.
	18.5	The right upper 5-digit monitor display the BW and right lower monitor display 13 for different bandwidth. The range is 00~15, Default is 13.

Table 6-2: Function Keypad Description

6.2 WAVE Keypad Description

The WAVE keypad is used for CC and CP models of operation only. In all other modes, the backlights for these keys are off.

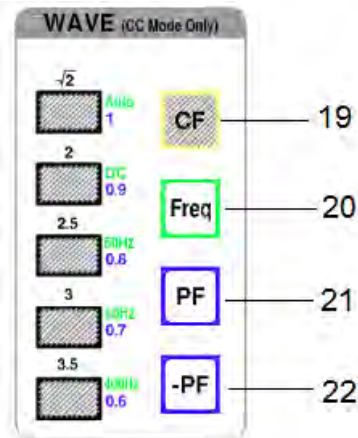

Call-out #	Description
19	CF key and $\sqrt{2}$, 2, 2.5, 3, 3.5 keys
	CF key only functions upon CC and CP mode and all LED off upon Linear CC, CR and CV mode.
	$\sqrt{2}$, 2, 2.5, 3, 3.5 keys are used to quick change the current CF (Crest Factor) of CC mode. However, adjust the CF by number key or Up, Down or rotary switch to setting the C.F. values.
20	Freq Key and Auto, DC, 50Hz, 60Hz and 400Hz key
	Freq key only functions upon CC and CP mode and all LED off upon Linear CC, CR and CV mode.
	Auto, DC, 50Hz, 60Hz and 400Hz keys are used to quick change the frequency of CC and CP mode. However, adjust the frequency by number key or Up, Down or rotary switch to setting the frequency values. The range is 40 ~ 440 Hz or 40 ~ 800 Hz depending on MODE
21	PF Key and 1, 0.9, 0.8, 0.7 and 0.6 key
	PF (lead) key only functions upon CC and CP mode and all LED off upon Linear CC, CR and CV mode.
	1, 0.9, 0.8, 0.7 and 0.6 keys are used to quick change the PF (Crest Factor) of CC and CP mode. However, adjust the PF by number key or Up, Down or rotary switch to setting the P.F. values. The range is 0 ~ 1.
22	PF Key and 1, 0.9, 0.8, 0.7 and 0.6 key
	PF (lag) key only functions upon CC and CP mode and all LED off upon Linear CC, CR and CV mode.
	1, 0.9, 0.8, 0.7 and 0.6 keys are used to quick change the PF (Crest Factor) of CC and CP mode. However, adjust the PF by number key or Up, Down or rotary switch to setting the PF values. The range is 0 ~ -1.

Table 6-3: WAVE Keypad Description

6.3 Test Function Keypad Description

The Test Function keypad has supports the Test mode of operation and has only four keys.

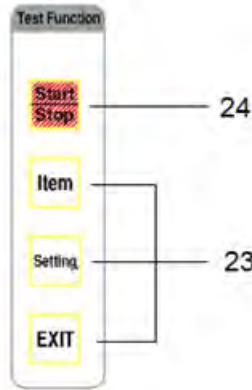

#	sub	Description
23		Item, Setting and Exit key for Test Item
		Test item as following
	23.1	Short test function
	23.2	OPP test function
	23.3	OCP test function
	23.4	Non-L (Non Linear) function test for UPS efficiency measurement
	23.5	NL-CR function for PV inverter efficiency measurement
	23.6	Fuse function test for fuse blow or breaker trip time test
	237	Batt (Battery) function for battery discharge test in DC mode or UPS back-up time in AC mode.
23.8	Trans(transfer time) function test for UPS transfer time test	
25		Start/Stop key
		Start/Stop key for function test start or stop test

Table 6-4: Test Function Keypad Description

6.4 Rotary Knob and ENTRY Keypad Description

The rotary knob or shuttle is useful for slewing set value up or down or adjusting the load dynamically. The other keys in the data ENTRY keypad are the cursor keys, decimal keys, Clear, Enter and Backspace keys.

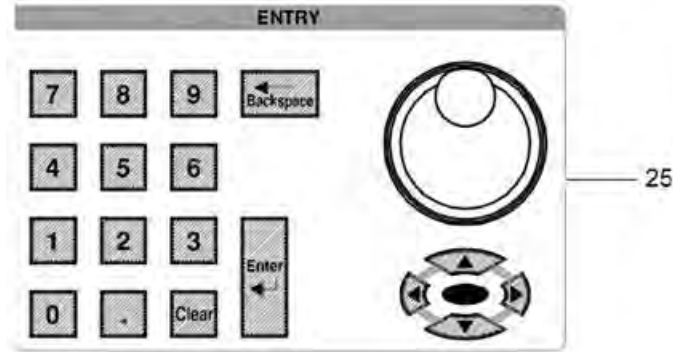

Call-out #	Description
25	Clock wise the rotary switch and UP arrow key to increase the setting values and anti-clockwise the rotary switch and DOWN arrow key to decrease the setting values.
	Key pad for enter number key directly and press Enter key to confirm the setting value, Clear key to clear the enter number.
	Note: In CR mode, increases set value defined for current value, so rotary knob clockwise or pressing the UP key will decrease the resistance and increase the current value. Anti-clockwise rotary switch rotation or pressing the DOWN key will increase the resistance value and decrease the current value.

6.4.1 Synchronization Source Setting

Synchronization of load current with AC input voltage is accomplished in one of two available SYNC modes:

- EXTERNAL SYNC
- INTERNAL SYNC

In **EXTERNAL SYNC** mode, the user must provide an input SYNC signal to the Ext. Sync. Input BNC terminal of the back panel of the load chassis.

The load will synchronize the current waveform to be in phase with the external SYNC signal.

Note: The external SYNC input signal must have a duty cycle of 50%.

In **INTERNAL SYNC** mode, the internal SYNC signal is taken from the sensed input voltage using the loads internal zero crossing detection and isolation circuits.

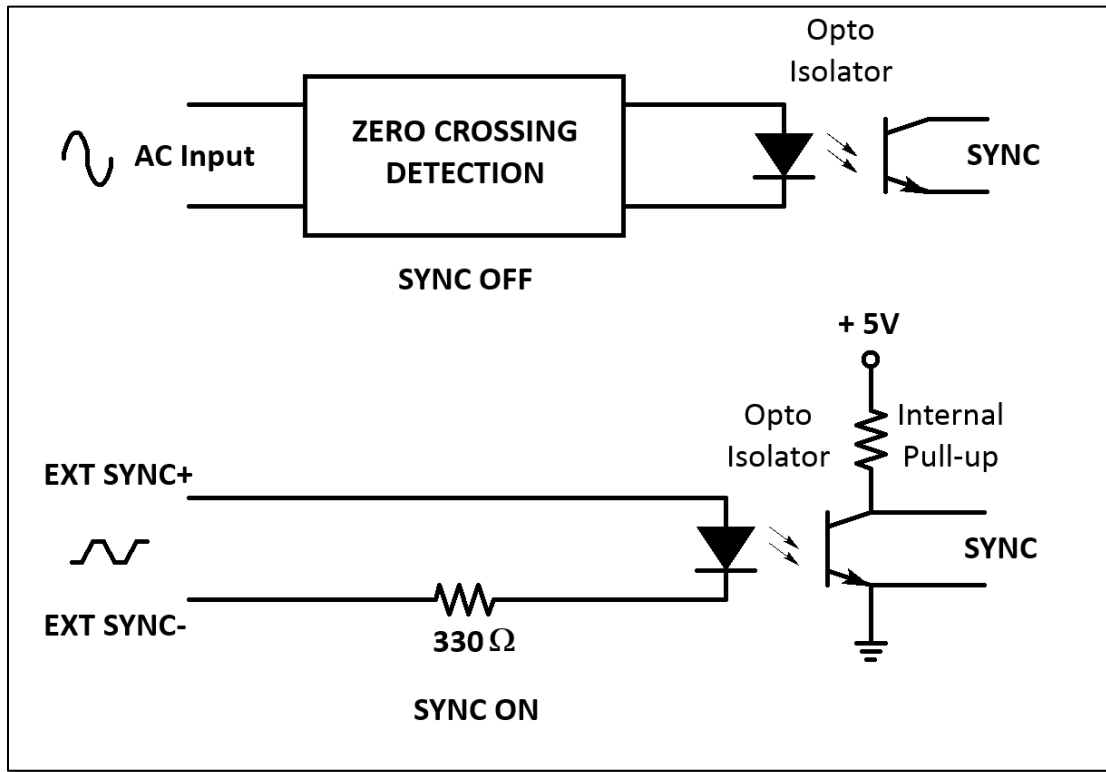

Table 6-5: Internal or External Sync Circuits

6.5 Operating Modes

The chart below shows the available operating modes of the AC & DC Load.

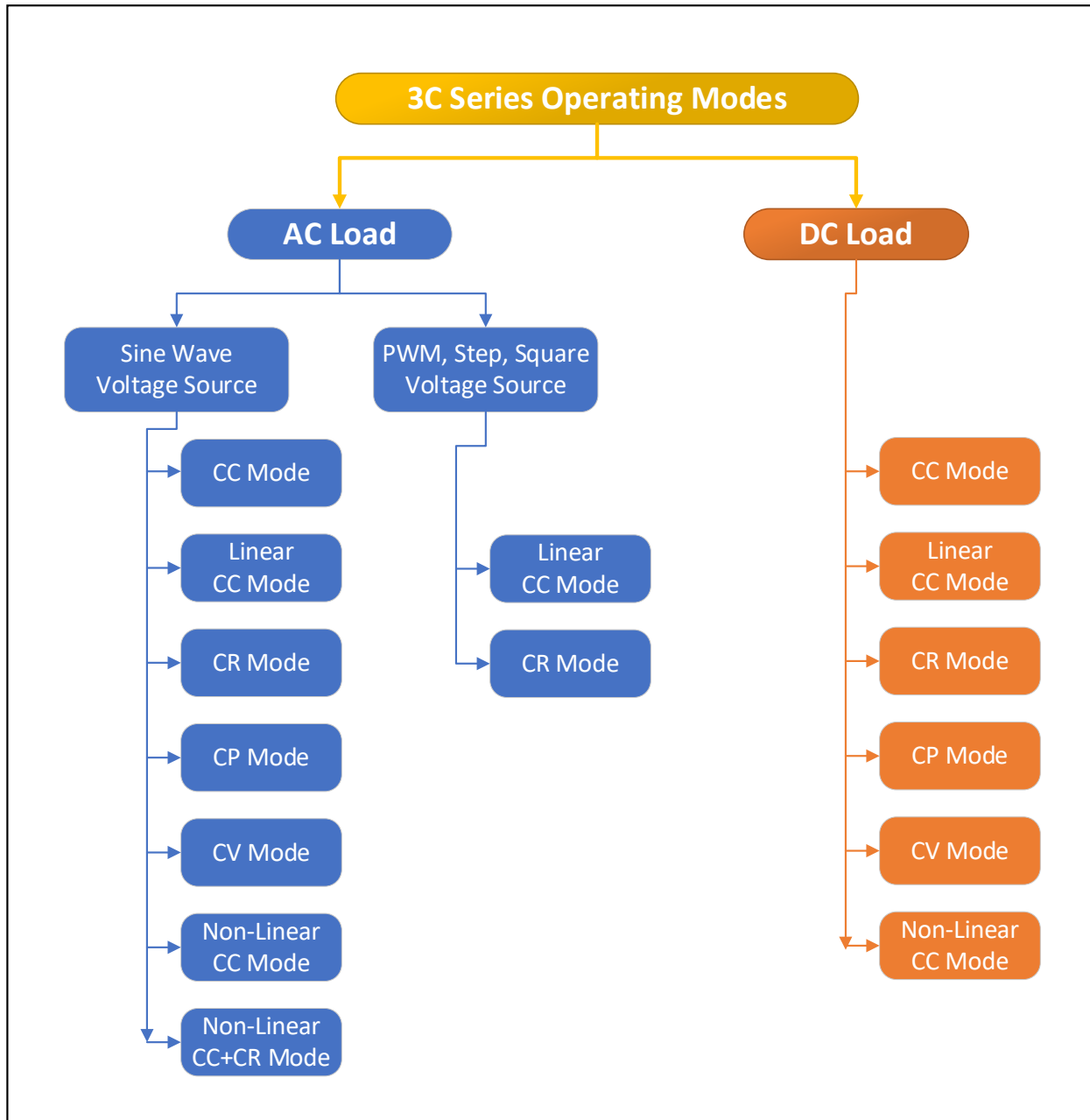

Figure 6-3: Diagram of available Operating Modes

6.6 Test Modes

In addition to the typical load operating modes listed in the previous section, the 3C Series load also incorporated the test functions shown in the diagram below. For more details on some of these test modes, refer to Section 3.3, “Load Applications & Test Modes” on page 15.

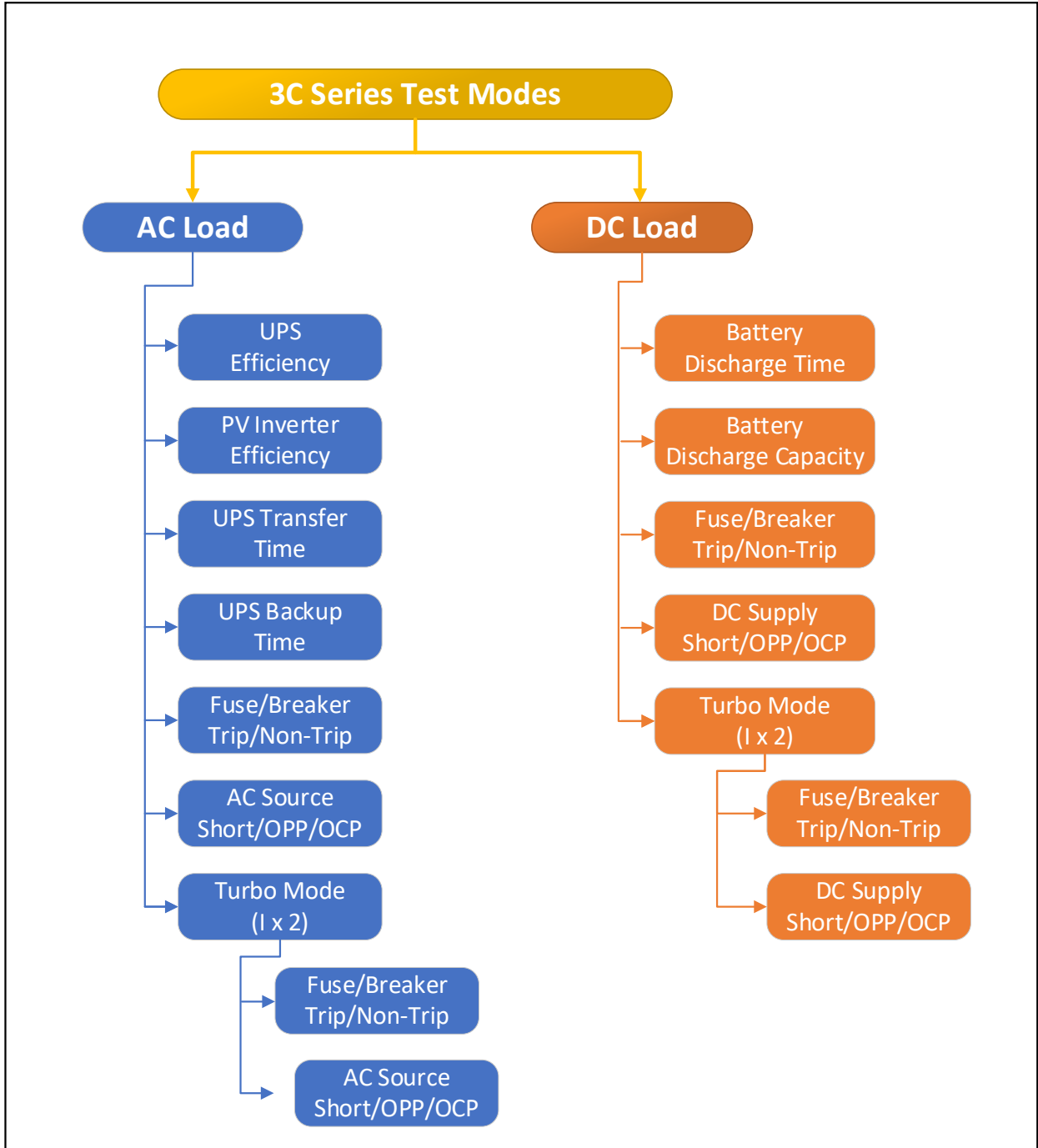

Figure 6-4: Diagram of available Test Modes

6.7 Measurement Functions

The 3C Series has an extensive array of precision measurement functions using 16-bit A/D convertors for enhanced resolution.

Available measured parameters include:

- Voltage rms (Vrms)
- Current rms (Arms)
- Watts (Watt)
- Volt-Ampere (VA)
- Crest Factor (CF)
- Power Factor (PF)
- Total Harmonic Voltage Distortion (VTHD)
- Voltage Harmonics (VH)
- Total Current Harmonic Distortion (ITHD)
- Current Harmonics (IH)
- Peak Current (Ipeak)
- Maximum Ampere (Amax)
- Minimum Ampere (Amin)
- Maximum Voltage (Vmax)
- Minimum Voltage (Vmin)

In addition to these measurement functions, the load also provides time measurement, such as UPS back up time, fuses and circuit breakers trip or blow time and Off-line UPS transfer time.

6.8 STORE / RECALL Settings

The AC+DC Load is designed to support high throughput production testing as needed. To this end, it allows for storing up to 150 setups including test steps in internal non-volatile memory.

6.8.1 Storing Settings



To **STORE** a setup:

1. Program the load to the desired setting and preset load mode and levels.
2. Press the **STORE** key to enter the STORE mode.
3. Press the UP or DOWN key or used the numeric keypad to adjust the displayed storage locations (1 ~ 150)
4. Press the ENTER OK button to save the setup state in the designated memory location.

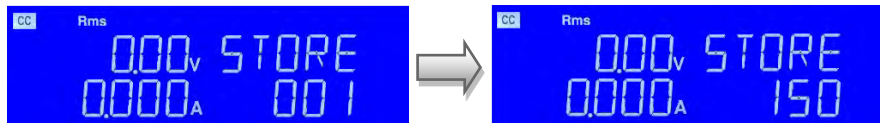

6.8.2 Recalling Settings



To **RECALL** a previously stored setup:

1. Press the **RECALL** to enter the recall state
2. Press the UP or DOWN key or used the numeric keypad to adjust the displayed storage locations (1 ~ 150)
3. Press the **ENTER** key to confirm.
4. The setting from the selected memory location are now loaded.

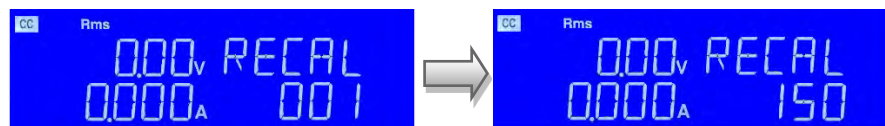

6.9 Sequence Testing



The sequence mode allows a series of stored setting to be re-called and used sequentially as part of a sequence list. This section covers test operation using the Sequence mode.

To enter the Sequence mode, press the **SEQ** key to enter **SEQ** setting mode. The LED indicator for the Sequence mode will be ON.

The setting sequence is as follows: Use UP and DOWN keys to set EDIT F1 or TEST F1 mode, if you want to Leave SYSTEM (Exit).

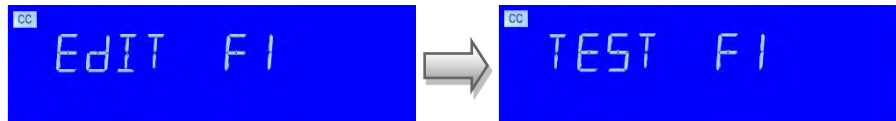

6.9.1 Sequence EDIT mode

Press the SHIFT key, and then press the SEQ. key to enter the AUTO SEQUENCE Mode.

STATE SELECTION

Press the UP, DOWN key to select EDIT. The LCD display now shows “EDIT” on the left hand side 5 -Digit LCD display. The right hand side 5-digit LCD display shows “FX”. “FX” means to select State F1-F9. Press the keypad 1 ~ 9 keys to choose F1 ~ F9.

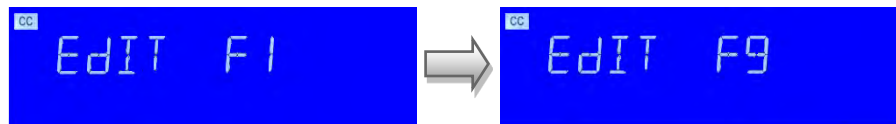

Press ENTER key. The LCD display shows “FX-XX” on left 5-digit display. The middle 5-digit LCD displays “STATE”. The right 5-digit LCD displays setting 1~150, “FX”. This means selected **STATE** is from F1 to F9. “XX” means the test STEP 01~6. Press UP and down Key or use the keypad to adjust the **STATE** setting.

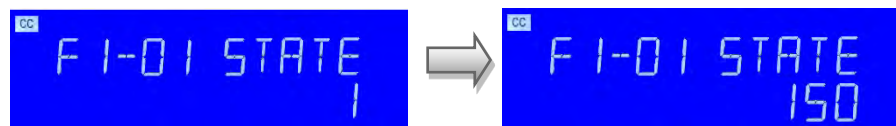

TEST TIME SETTING

Press ENTER to set **TIME** value, then press the UP, DOWN keys or use the KEYPAD to adjust the test time settings. Available range is from 100 ms ~ 9999ms.

Press ENTER key or SAVE key to finish editing the action is set to REPEAT,

If you do not save the settings, press the EXIT key to leave edit mode.

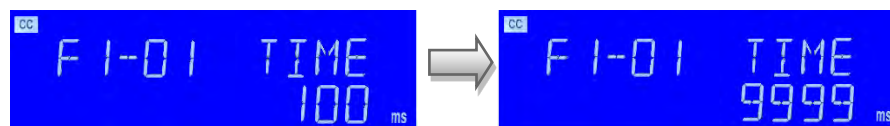

TEST REPEAT SETTING

Press UP and DOWN key or Keypad to adjust the Repeat setting from 0~9999. Press the ENTER SAVE REPEAT Value, or press EXIT key to exit the EDIT MODE.

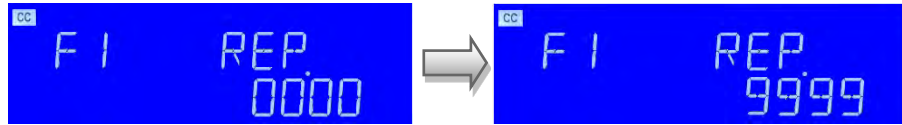

6.9.2 Sequence EDIT Mode Flow Chart

The flow chart below describes the various Edit settings.

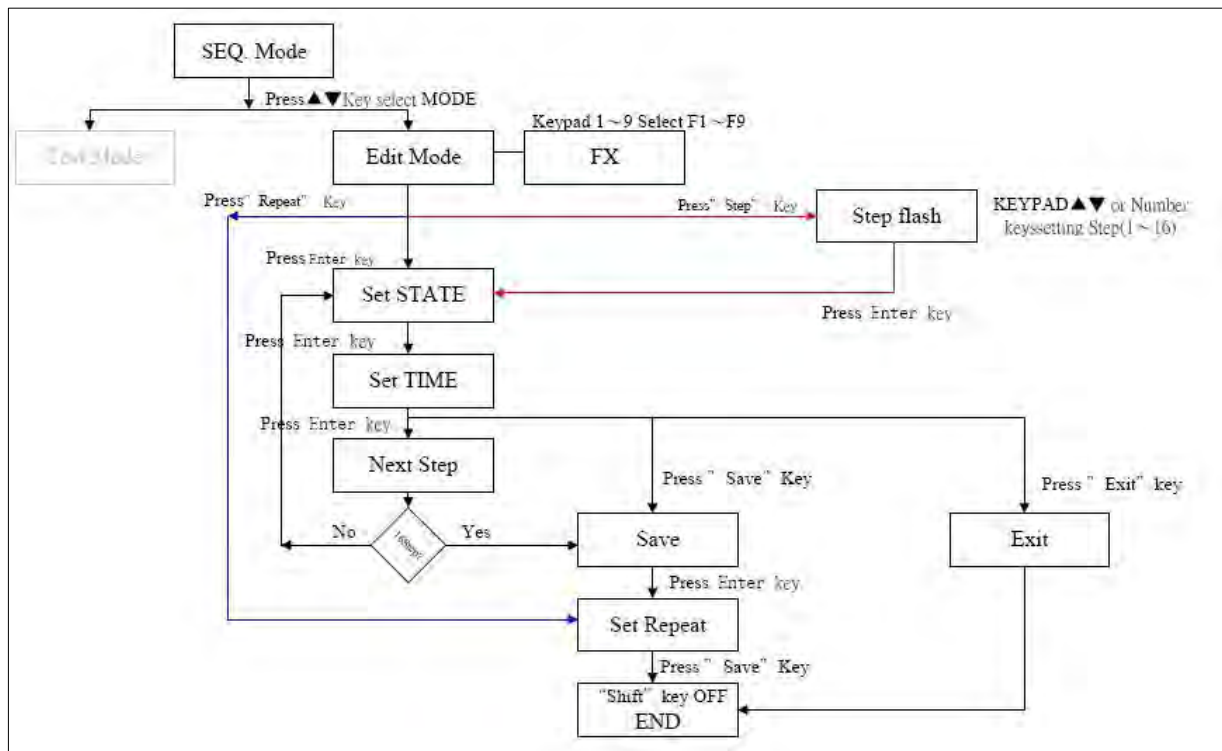
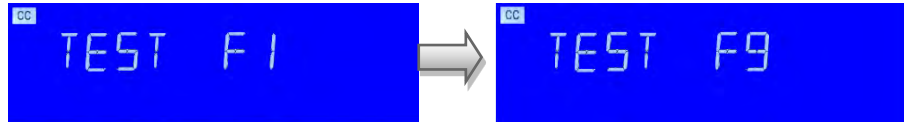

Figure 6-5: Sequence EDIT Mode Operation Flow Chart

6.9.3 Sequence TEST Mode

Press the SEQ. key to enter the **AUTO SEQUENCE** Mode. Next, press the UP, DOWN key to select **TEST** mode. The left hand-side 5-digit monitor displays “**TEST**”, the right hand side 5-digit monitor displays “**FX**”. “FX” means state F1-F9 is selected.

Press the keypad keys 1 ~ 9 to choose F1 ~ F9. Press ENTER to enter the next automatic test Mode.



Test LCD will now display "SXX", "XX" on behalf of the test of STEP. If the test Result is No-Go (**NG**), the LCD will show "**NG**" (flashing) and the test sequence will be suspended.

The user can now either press the **ENTER** key to continue the test anyway or press the **EXIT** key to leave the test mode. Test mode can be continued by the (STEP01 - TIME) then (SETP02 - TIME) until all the steps are done.

If all the test steps are OK, the test result is PASS and the LCD displays "**PASS**".

If any of the test steps result in a **NG**, the test result is FAIL. The LCD will display "FAIL". If the buzzer is set to ON and the test result is PASS, the buzzer will sound once. If the test result is FAIL, the buzzer will sound two times instead.

When the test is completed, the user can press the ENTER key again to re-start the same test sequence or press the EXIT key to leave the test mode.

The example here shows the 16-step test sequence is completed and the TEST passed as the LCD displays "**PASS**".

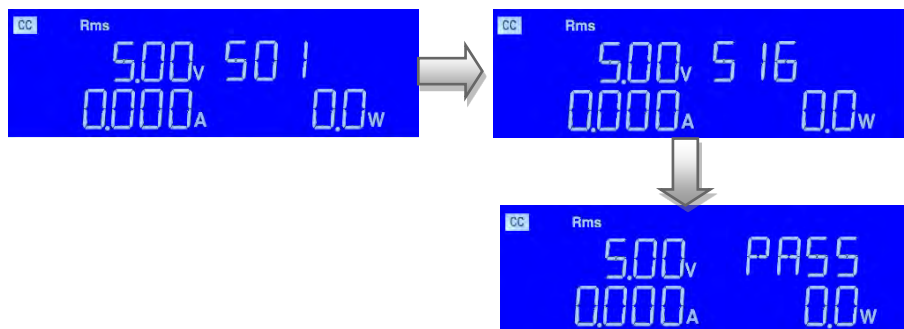

6.9.4 Sequence TEST Mode Flow Chart

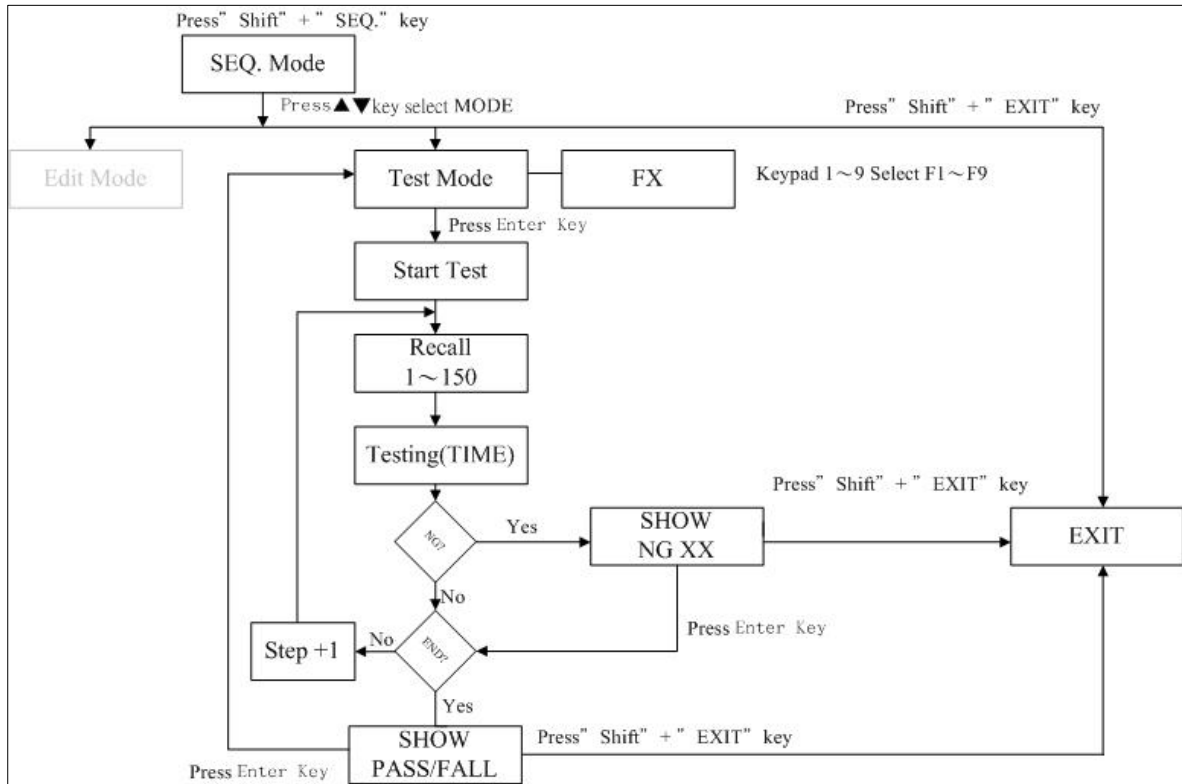

Figure 6-6: Sequence TEST Mode Operation Flow Chart

6.10 Initial Power-on Settings

6.10.1 Last Setting Recall

All 3C Series loads support a ‘last setup recall’ feature. The 3C load will return to the last setup state in effect at power off. This occurs the next time the load is turned back on and immediately following its power-on self-test. So rather than returning to the factory default setting shown in the tables above, it will return to the last state in which it was used.

Other setups can be recalled using the FUNCTION Keypad Recall button. There are 150 Setup memory locations.

6.10.2 Factory Default Initial Settings

When shipped from the factory, 3C Series initial settings after power ON are as shown in the tables below by model number.

6.10.2.1 Model 3C018-18 Initial Settings

Setting	Initial Value	Setting	Setting	Initial Value	
CC A+ Preset	0.000 A	LIMIT	V_Hi	600.00 V	
CC B+ Preset	0.000 A		V_Lo	0.00 V	
LIN A+ Preset	0.000 A		I_Hi	20.000 A	
LIN B+ Preset	0.000 A		I_Lo	0.000 A	
CR A+ Preset	64000 Ω		W_Hi	2000.0 W	
CR B+ Preset	64000 Ω		W_Lo	0.0 W	
CP A+ Preset	0.0 W		VA_Hi	2000.0 VA	
CP B+ Preset	0.0 W		VA_Lo	0.0 VA	
CV A+ Preset	500.00 V		OPC	1968.75 W	
CV B+ Preset	500.00 V		OCL	19.687 A	
			CONFIG	EXTIN	OFF
				SYNC	OFF
		LD-OFF		5.00 V	
		LD-ON		10.00 V	
			BW	13	

Table 6-6: Model 3C018-18 Factory Settings

6.10.2.2 Model 3C028-18-EV Initial Settings

Setting	Initial Value	Setting	Setting	Initial Value
CC A+ Preset	0.000 A	LIMIT	V_Hi	600.00 V
CC B+ Preset	0.000 A		V_Lo	0.00 V
LIN A+ Preset	0.000 A		I_Hi	20.000 A
LIN B+ Preset	0.000 A		I_Lo	0.000 A
CR A+ Preset	64000 Ω		W_Hi	3000.0 W
CR B+ Preset	64000 Ω		W_Lo	0.0 W
CP A+ Preset	0.0 W		VA_Hi	3000.0 VA
CP B+ Preset	0.0 W		VA_Lo	0.0 VA
CV A+ Preset	500.00 V		OPC	1968.75 W
CV B+ Preset	500.00 V		OCL	19.687 A
		CONFIG	EXTIN	OFF
			SYNC	OFF
			LD-OFF	5.00 V
			LD-ON	10.00 V
			BW	13

Table 6-7: Model 3C028-18-EV Factory Settings

6.10.2.3 Model 3C028-28 Initial Settings

Setting	Initial Value	Setting	Setting	Initial Value
CC A+ Preset	0.000 A	LIMIT	V_Hi	600.00 V
CC B+ Preset	0.000 A		V_Lo	0.00 V
LIN A+ Preset	0.000 A		I_Hi	30.000 A
LIN B+ Preset	0.000 A		I_Lo	0.000 A
CR A+ Preset	42666 Ω		W_Hi	3000.0 W
CR B+ Preset	42666 Ω		W_Lo	0.0 W
CP A+ Preset	0.0 W		VA_Hi	3000.0 VA
CP B+ Preset	0.0 W		VA_Lo	0.0 VA
CV A+ Preset	500.00 V		OPC	2940.0 W
CV B+ Preset	500.00 V		OCL	29.40 A
		CONFIG	EXTIN	OFF
			SYNC	OFF
			LD-OFF	5.00 V
			LD-ON	10.00 V
			BW	13

Table 6-8: Model 3C028-28 Factory Settings

6.10.2.4 Model 3C038-28-EV Initial Settings

Setting	Initial Value	Setting	Setting	Initial Value
CC A+ Preset	0.000 A	LIMIT	V_Hi	600.00 V
CC B+ Preset	0.000 A		V_Lo	0.00 V
LIN A+ Preset	0.000 A		I_Hi	30.000 A
LIN B+ Preset	0.000 A		I_Lo	0.000 A
CR A+ Preset	42666 Ω		W_Hi	4000.0 W
CR B+ Preset	42666 Ω		W_Lo	0.0 W
CP A+ Preset	0.0 W		VA_Hi	4000.0 VA
CP B+ Preset	0.0 W		VA_Lo	0.0 VA
CV A+ Preset	500.00 V		OPC	3937.5 W
CV B+ Preset	500.00 V		OCL	29.40 A
		CONFIG	EXTIN	OFF
			SYNC	OFF
			LD-OFF	5.00 V
			LD-ON	10.00 V
			BW	13

Table 6-9: Model 3C038-28-EV Factory Settings

6.10.2.5 Model 3C038-38 Initial Settings

Setting	Initial Value	Setting	Setting	Initial Value
CC A+ Preset	0.000 A	LIMIT	V_Hi	600.00 V
CC B+ Preset	0.000 A		V_Lo	0.00 V
LIN A+ Preset	0.000 A		I_Hi	40.000 A
LIN B+ Preset	0.000 A		I_Lo	0.000 A
CR A+ Preset	32000 Ω		W_Hi	4000.0 W
CR B+ Preset	32000 Ω		W_Lo	0.0 W
CP A+ Preset	0.0 W		VA_Hi	4000.0 VA
CP B+ Preset	0.0 W		VA_Lo	0.0 VA
CV A+ Preset	500.00 V		OPC	3937.5 W
CV B+ Preset	500.00 V		OCL	39.375 A
		CONFIG	EXTIN	OFF
			SYNC	OFF
			LD-OFF	5.00 V
			LD-ON	10.00 V
			BW	13

Table 6-10: Model 3C038-38 Factory Settings

6.10.2.6 Model 3C058-58 Initial Settings

Setting	Initial Value	Setting	Setting	Initial Value
CC A+ Preset	0.000 A	LIMIT	V_Hi	600.00 V
CC B+ Preset	0.000 A		V_Lo	0.00 V
LIN A+ Preset	0.000 A		I_Hi	40.000 A
LIN B+ Preset	0.000 A		I_Lo	0.000 A
CR A+ Preset	21333 Ω		W_Hi	6000.0 W
CR B+ Preset	21333 Ω		W_Lo	0.0 W
CP A+ Preset	0.0 W		VA_Hi	6000.0 VA
CP B+ Preset	0.0 W		VA_Lo	0.0 VA
CV A+ Preset	500.00 V		OPC	5888.0 W
CV B+ Preset	500.00 V		OCL	58.80 A
		CONFIG	EXTIN	OFF
			SYNC	OFF
			LD-OFF	5.00 V
			LD-ON	10.00 V
			BW	13

Table 6-11: Model 3C038-38 Factory Settings

6.10.2.7 Model 3C075-75 Initial Settings

Setting	Initial Value	Setting	Setting	Initial Value
CC A+ Preset	0.000 A	LIMIT	V_Hi	600.00 V
CC B+ Preset	0.000 A		V_Lo	0.00 V
LIN A+ Preset	0.000 A		I_Hi	80.000 A
LIN B+ Preset	0.000 A		I_Lo	0.000 A
CR A+ Preset	16000 Ω		W_Hi	8000.0 W
CR B+ Preset	16000 Ω		W_Lo	0.0 W
CP A+ Preset	0.0 W		VA_Hi	8000.0 VA
CP B+ Preset	0.0 W		VA_Lo	0.0 VA
CV A+ Preset	500.00 V		OPC	7875 W
CV B+ Preset	500.00 V		OCL	78.75 A
		CONFIG	EXTIN	OFF
			SYNC	OFF
			LD-OFF	5.00 V
			LD-ON	10.00 V
			BW	13

Table 6-12: Model 3C075-75 Factory Settings

6.10.2.8 Model 3C112-112 Initial Settings

Setting	Initial Value	Setting	Setting	Initial Value
CC A+ Preset	0.000 A	LIMIT	V_Hi	600.00 V
CC B+ Preset	0.000 A		V_Lo	0.00 V
LIN A+ Preset	0.000 A		I_Hi	120.000 A
LIN B+ Preset	0.000 A		I_Lo	0.000 A
CR A+ Preset	10667 Ω		W_Hi	11200.0 W
CR B+ Preset	10667 Ω		W_Lo	0.0 W
CP A+ Preset	0.0 W		VA_Hi	11200.0 VA
CP B+ Preset	0.0 W		VA_Lo	0.0 VA
CV A+ Preset	500.00 V		OPC	11812 W
CV B+ Preset	500.00 V		OCL	118.12 A
		CONFIG	EXTIN	OFF
			SYNC	OFF
			LD-OFF	5.00 V
			LD-ON	10.00 V
			BW	13

Table 6-13: Model 3C112-112 Factory Settings

6.10.2.9 Model 3C150-112 Initial Settings

Setting	Initial Value	Setting	Setting	Initial Value
CC A+ Preset	0.000 A	LIMIT	V_Hi	600.00 V
CC B+ Preset	0.000 A		V_Lo	0.00 V
LIN A+ Preset	0.000 A		I_Hi	120.000 A
LIN B+ Preset	0.000 A		I_Lo	0.000 A
CR A+ Preset	10667 Ω		W_Hi	15000.0 W
CR B+ Preset	10667 Ω		W_Lo	0.0 W
CP A+ Preset	0.0 W		VA_Hi	15000.0 VA
CP B+ Preset	0.0 W		VA_Lo	0.0 VA
CV A+ Preset	500.00 V		OPC	15750 W
CV B+ Preset	500.00 V		OCL	118.12 A
		CONFIG	EXTIN	OFF
			SYNC	OFF
			LD-OFF	5.00 V
			LD-ON	10.00 V
			BW	13

Table 6-14: Model 3C150-112 Factory Settings

6.10.2.10 Model 3C188-112 Initial Settings

Setting	Initial Value	Setting	Setting	Initial Value
CC A+ Preset	0.000 A	LIMIT	V_Hi	600.00 V
CC B+ Preset	0.000 A		V_Lo	0.00 V
LIN A+ Preset	0.000 A		I_Hi	120.000 A
LIN B+ Preset	0.000 A		I_Lo	0.000 A
CR A+ Preset	10667 Ω		W_Hi	18750.0 W
CR B+ Preset	10667 Ω		W_Lo	0.0 W
CP A+ Preset	0.0 W		VA_Hi	18750.0 VA
CP B+ Preset	0.0 W		VA_Lo	0.0 VA
CV A+ Preset	500.00 V		OPC	19687 W
CV B+ Preset	500.00 V		OCL	118.12 A
		CONFIG	EXTIN	OFF
			SYNC	OFF
			LD-OFF	5.00 V
			LD-ON	10.00 V
			BW	13

Table 6-15: Model 3C188-112 Factory Settings

6.10.2.11 Model 3C225-112 Initial Settings

Setting	Initial Value	Setting	Setting	Initial Value
CC A+ Preset	0.000 A	LIMIT	V_Hi	600.00 V
CC B+ Preset	0.000 A		V_Lo	0.00 V
LIN A+ Preset	0.000 A		I_Hi	120.000 A
LIN B+ Preset	0.000 A		I_Lo	0.000 A
CR A+ Preset	10667 Ω		W_Hi	22500.0 W
CR B+ Preset	10667 Ω		W_Lo	0.0 W
CP A+ Preset	0.0 W		VA_Hi	22500.0 VA
CP B+ Preset	0.0 W		VA_Lo	0.0 VA
CV A+ Preset	500.00 V		OPC	23625 W
CV B+ Preset	500.00 V		OCL	118.12 A
		CONFIG	EXTIN	OFF
			SYNC	OFF
			LD-OFF	5.00 V
			LD-ON	10.00 V
			BW	13

Table 6-16: Model 3C225-112 Factory Settings

6.11 Protection Features

The 3C Series electronic loads include the following protection features:

- Over Voltage
- Over Current
- Over Power
- Over Temperature

If any of these conditions occur, the load will turn off to protect itself from any damage resulting from abnormal use. The protection status is indicated by a flashing display to notify the operator of a protection fault.

6.11.1 Over Voltage Protection

The over voltage protection circuit is set at a predetermined voltage, which **cannot** be changed. If the over voltage circuit has tripped, the load input turns OFF immediately to prevent damaging the load. When an over-voltage trip condition has occurred, the display will indicate "OVP" and flash ON and OFF. Once the over voltage condition disappears, the display will revert to normal operation.

The over-voltage trip point is set to 105% of range and **cannot be adjusted**.

CAUTION

Never apply excessive input voltage to the load, either Vac or Vdc.

The load has no means to disconnect itself from the power source being tested so excessive voltage WILL damage the load's power device.

This type of damage is NOT covered by the warranty.

6.11.2 Over Current Protection

The load always monitors the current it is sinking. When the current sink is greater than 105% of the rated maximum current, the load will change to the OFF state internally. When an over current condition has occurred, the display will indicate "OCP" and flash ON and OFF. Once the over current condition disappears, the display will revert to normal operation. The OCP level can be programmed by the user from 0 to 105%.

6.11.3 Over Power Protection

The load always monitors the power dissipated by the load. When the power dissipation is greater than 105% of the rated power input, the load will change to the OFF state internally. When an over power condition has occurred, the display will indicate "OPP" and flash ON and OFF. Once the over power condition disappears, the display will revert to normal operation. The OPP level can be programmed by the user from 0 to 105%.

6.11.4 Over Temperature Protection

As soon as the temperature of load's internal heat sinks reaches a level greater than 100° C (212° F), the over temperature protection is triggered. The display will indicate "OTP" and flash ON and OFF. Once the over temperature condition disappears, the lower display monitor will revert to normal operation.

Please check environmental conditions such as the ambient temperature and distance between the rear panel of the load chassis and any wall is greater than 15cm / 6 inches.

7 Real Panel Connections

This section describes the various connectors available on the 3C Series AC & DC load.

7.1 Rear Panel Layout

All connectors are located at the rear panel of the load. The figure below shows the 3C Series rear panel layout.

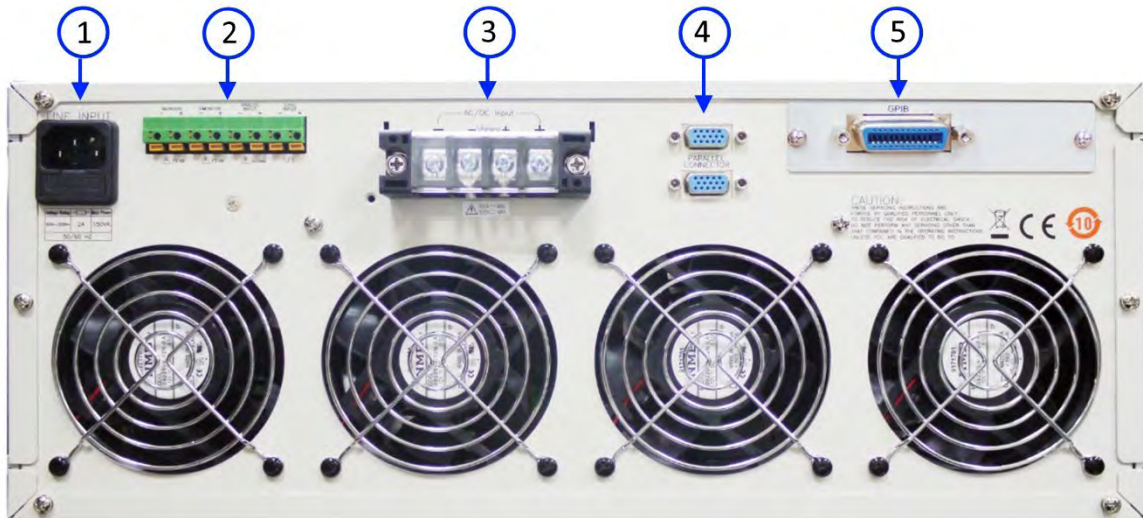

Figure 7-1: Rear Panel Connector Locations

1. AC power line cord input connector
2. Analog I/O Connector
3. Load Input and Voltage Sense Connector
4. Master/Slave Mode System Bus Connectors
5. Optional Interface (USB, LAN, RS232 or GPIB)

7.2 INPUT Terminals

Note: Always refer to Section 2.3 “Safety Information” and Section 2.4 “Safety Notices” before making any load connections.

The positive (high) and negative (low) terminal strip for load input and remote voltage sense connections are located on rear panel. The Input terminal strip used on the 3C Series loads can be connected to the unit under test using the included ring lugs terminated with wires of adequate size to support the maximum current the load can sink. Ring lugs for both Load and VSense connections are provided in the ship kit.

7.3 Wire Size

A major consideration in making input connection is the wire size. The minimum wire size is required to prevent overheating and to maintain good regulation. It is recommended that the wires are sized large enough to limit the voltage drop at the maximum current rating of the AC & DC load to less than 0.5V per connection lead.

7.4 Connecting a UUT

WARNING

DO NOT EXCEED LOAD INPUT VOLTAGE RATING

This instrument does **NOT** have a means to disconnect its Load input from a connected power supply. If the voltage applied to the Load input exceeds its maximum rating – even if the load is turned completely off – damage to the load **WILL** occur. Damage caused by exceeded maximum load input voltage under any circumstance is **NOT** covered by the manufacturer’s product warranty. Remove any load input connections when the load is not in use, even when it is turned off.

When setting up for a new test and connecting any equipment to the AC & DC load, proceed as follows:

1. Always make sure the AC & DC load is turned OFF at the POWER switch when making any wire connections.
2. Check that the output of the equipment under test is **OFF**.
Note: Some power equipment’s output may still be energized even if the equipment has been turned off or its output is turned off. This is especially true for DC power supplies.

Note: When working with batteries, it is recommended to provide a suitable disconnect relay or switch so the load connection can be disconnected from the battery for handling purposes.

3. Connect one end of the load wires to the load input terminals on the rear panel.
4. Check the polarity of the connections and connect the other end of the load wires to the output terminal of the equipment under test.
5. When connecting multiple loads to the same EUT, makes sure the load wire lengths to each load are the same.

7.5 Voltage Sense Input Terminals

To measure the UUT output voltage at the EUT terminals rather than the load input terminals, the external voltage sense mode must be used. The external voltage sense wire harness is provided for this purpose. It connects to the Voltage sense connector terminals (Vs+ and Vs-) on the rear panel of the load. Make sure the polarity of the power connections and the voltage sense connections are both correct. Ring lug terminals for both Power and VSense connections are included in the ship kit.

For small loads that deliver only low levels of current, INTERNAL sense can be used. For larger loads that draw a considerable amount of current, EXTERNAL sense mode will compensate for voltage drop along the load connection wires. Refer to Figure 7-2 below. Maximum voltage sense compensation is equal to the 3C Load voltage rating.

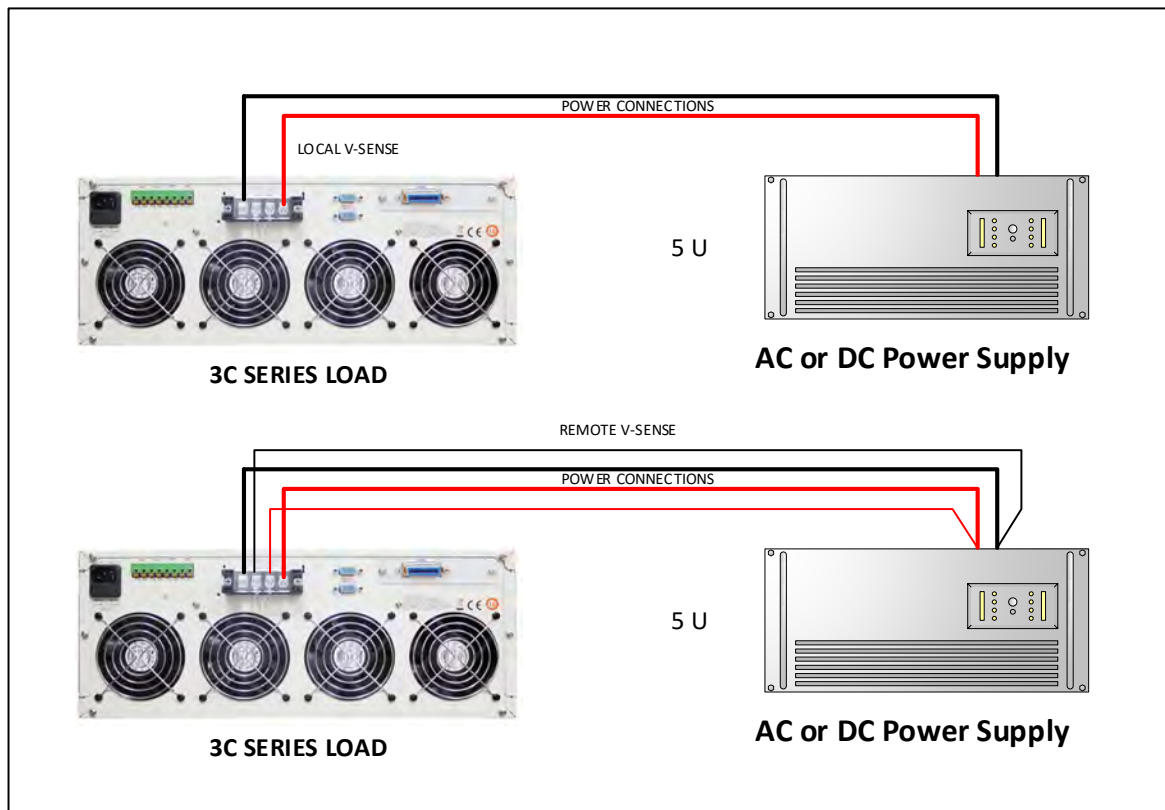

Figure 7-2: Internal and External Voltage Sense Connections

7.6 Current Output Monitor (I-Monitor)

The I-Monitor terminal is designed to monitor the electronic load's sink current. An isolated amplifier output with a 0 - 4Vrms / 0 – 10Vpp full scale output signal represents the zero to full scale current the electronic load is sinking. Regardless of Preset ON or OFF state, the analog signal output from the I-monitor is in direct proportion to the load current flowing through the load. Please refer to the I-Monitor voltage /current scaling values for each 3C Series load in Section 4, "Technical Specifications" on page 49.

7.6.1 Isolated Output

The insulation voltage rating between the AC input end of the 3C Series electronic load and the I-monitor BNC output end is 500V. Also, the reference potential at the negative end of BNC is the same as the GPIB connector earth potential of the load.

As the isolated insulation amplifier inside the load provides a convenient testing solution as it solves the problem of isolating voltage and current monitoring and eliminates the potential short circuit or ground loop issues that can occur when a single oscilloscope is used for monitoring both voltage and current.

Since most oscilloscope input channels BNC shields are chassis grounded, connecting two or more channels with different ground references normally requires additional isolation probes.

The I-monitor BNC output signal on 3C Series loads is through an isolation amplifier, e.g., the earth potential of the output analog signal and the earth potential of the load input are electrically isolated from each other. In this way, when a connection is made to an oscilloscope on which another input channel is connected to both the high and low side of the load to monitor voltage, no metering error results from any current flowing between the negative end of the I-monitor BNC output and the negative end of the oscilloscope due to any voltage differential.

Note: The EUT source low side will still be grounded by connecting it to an oscilloscope channel input so if the source under test low side is not ground referenced, the voltage monitor channel will require the use of an isolation probe.

8 Remote Control Programming

8.1 Overview

If your unit is fitted with a computer interface option then a USB, LAN, GPIB or RS232 connector will be present on the rear panel. The interface allows the load settings to be configured remotely and measurement data to be retrieved for analysis and test report generation.

There are two sets of programming commands for APS Loads. One is referred to as the SHORT FORM commands and the other set as the LONG FORM commands.

For Example:

To query the actual voltage present at the load from the load's measurement system, the long form command is:

MEASURE:VOLTAGE?

The same command in its short form is:

MEAS:VOLT?

NOTE: When the USB, LAN or RS232 interface is used to control the load, it is important to send the "REMOTE" command first to make sure the load is in REMOTE state. To return the load to local operation, the "LOCAL" command is used. These two commands do not apply to the GPIB interface as remote and local state of an instrument is handled through the GPIB ATN hardware signal per the IEEE488 standard.

8.2 RS232 Set-up

The RS232 interface of the APS 3C load is configured as follows:

Baud-rate: 9600 bps
 Parity: None
 Data bit: 8 bits
 Stop bit: 1 bit
 Command delay: 20 msecs between successive commands is required to allow command parsing and processing.

Make sure the settings used on the controller's COM port match those of the load.

The RS232 interface connector DB9 pin-out of the load is shown in *Table 8-1*.

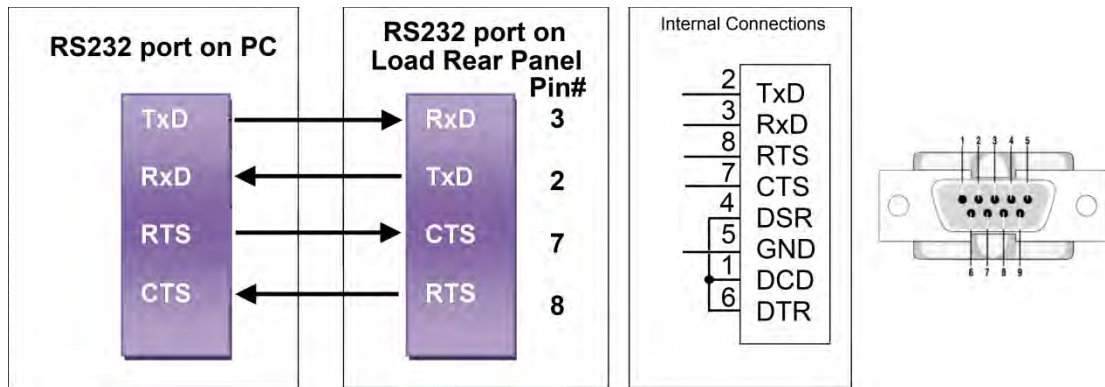

Figure 8-1: RS232 Connection to PC and DB9 Pin out

RS232 DB9 Signal Pin Assignments:

PIN	Abbreviation	Description
Pin1	CD	Carrier Detect
Pin2	TXD	Transmit Data
Pin3	RXD	Receive Data
Pin4	DTR	Data Terminal Ready
Pin5	GND	Ground
Pin6	DSR	Data Set Ready
Pin7	CTS	Clear to Send
Pin8	RTS	Request to Send
Pin9	RI	Ring Indicator

Table 8-1: RS232 DB9 Pin Assignments

8.3 Programming Syntax

A variety of syntax notations are used in the description of the remote control commands and in the summary tables. The syntax used is defined as follows:

- SP Space, the ASCII code is 20 hexadecimal.
- ; Semicolon, program line terminator, the ASCII code is 0A hexadecimal.
- NL New line, program line terminator, the ASCII code is 0A hexadecimal.
- NR2 Numeric value with decimal point. Values can be accepted in the range and format of ###.#####. For example: 30.12345. In this instance, the load will read up to five significant digits after the decimal point. The decimal point can be omitted if not required.

8.3.1 Parenthesis

The following parentheses are used in the command descriptions to indicate whether a command is necessary or optional and whether a choice has to be made. The symbols { }, [], and | are not actually used in the programming commands. The symbols { }, [] and | are merely used to illustrate the command syntax.

- { } - Required: The contents of the { } symbol must be used as part of the command, it cannot be omitted.
- [] - Optional: The contents of the [] symbol indicates that the command is optional. The use of the contents depends on the test application.
- | - Required Choice: This symbol means a choice must be made between the stated command key words. For example, “LOW|HIGH” Means a LOW or HIGH choice needs to be made as part of the command.
- ? - Query Command: The question mark implies the query format of the command.

8.3.2 Terminators

All remote control commands sent to the load must be terminated with a command terminator. The command terminator characters accepted by the APS loads are listed in *Table 8-2*.

Terminator	Hex Code	Decimal	C Code	Notes
LF	0x0A	10	\n	
LF+ EOI	0x0A	10	\n	GPIB only
CR+LF	0x0D + 0x0A	13 + 10	\r\n	
CR+LF+EOI	0x0D + 0x0A	13 + 10	\r\n	GPIB only

Table 8-2: Supported Command Terminators

Semicolon “;” The semicolon character allows you to combine multiple commands in one message string to create a command sequence. The commands will be parsed in the order in which they are received.

8.4 Command Syntax Tables – Short Form

The setting and query commands for the loads are listed in the summary tables below. Short form commands use an abbreviated syntax, which reduces the amount of characters required for each command and thus increases throughput.

8.4.1 Setting Commands

SETTING PRESET NUMERIC COMMAND	NOTES
HARM{SP} {NR2} {; NL}	HARMONICS 1~50
LIN:{A B} {SP} {NR2}{; NL}	
LDONV{SP} {NR2} {; NL}	
LDOFFV{SP} {NR2} {; NL}	
CC CURR:{A B} {SP} {NR2}{; NL}	
CP:{A B} {SP} {NR2}{; NL}	
CR RES:{A B} {SP} {NR2}{; NL}	
CV VOLT:{A B} {SP} {NR2}{; NL}	
CVI:{A B} {SP} {NR2}{; NL}	CV CURR
TCONFIG {SP} {NORMAL OCP OPP SHORT NLIN NLCR FUSE BATT TRANS } {; NL}	
OCP:START {SP} {NR2} {; NL}	
OCP:STEP {SP} {NR2} {; NL}	
OCP:STOP {SP} {NR2} {; NL}	
VTH {SP} {NR2} {; NL}	
OPP:START {SP} {NR2} {; NL}	
OPP:STEP {SP} {NR2} {; NL}	
OPP:STOP {SP} {NR2} {; NL}	
STIME {SP} {NR2} {; NL}	
PF {SP} {+ -} {NR2} {; NL}	Power factor
CF {SP} {NR2} {; NL}	Crest factor
BATT:MODE {SP}{CC LIN CV CP} {; NL}	
BATT:TIME {SP} {NR1} {; NL}	
DISC: TIME {?} {; NL}	
DISC: AH {?} {; NL}	
EXTIN{SP}{ON OFF} {; NL}	
TURBO {SP}{ON OFF} {; NL}	
FUSE:TIME {SP} {NR2} {; NL}	
FUSE:TYPE {SP} {TRIP NTRIP} {; NL}	
FUSE:REP {SP} {NR1} {; NL}	
AVG{SP} {NR2}{; NL}	NR2:1 2 4 8 16
CPRSP{SP} {NR2}{; NL} {; NL}	NR2:0~7
CYCLE{SP} {NR2}{; NL}	NR2:1~16
ON:ANG{SP} {NR2}{; NL}	0~359
OFF:ANG{SP} {NR2}{; NL}	0~359
BW {SP} {NR2}{; NL}	
FREQ {SP} {AUTO NR2}{; NL}	0,40~440Hz
ITIME {SP} {NR2}{; NL} 0.1ms~100.0ms	ITIME {SP} {NR2}{; NL} 0.1ms~100.0ms
ISTART {SP} {NR2}{; NL}	ISTART {SP} {NR2}{; NL}
ISTEP {SP} {NR2}{; NL}	ISTEP {SP} {NR2}{; NL}
ISTOP{SP} {NR2}{; NL}	ISTOP{SP} {NR2}{; NL}

SETTING PRESET NUMERIC COMMAND	NOTES
SURGE:Tn{SP} {NR2}{; NL}	SURGE:Tn{SP} {NR2}{; NL}
SURGE:Sn{SP} {NR2}{; NL}	SURGE:Sn{SP} {NR2}{; NL}
SNUB {SP}AUTO ON OFF{; NL}	SNUB {SP}AUTO ON OFF{; NL}

Table 8-3: Remote Control Setting Command Syntax - Short Form

8.4.1 Query Commands

QUERY PRESET NUMERIC COMMAND	RETURN
HARM{?}{SP} {NR2} {; NL}	###.####
LIN:{A B}{?}{SP} {NR2}{; NL}	###.####
LDONV{?}{SP} {NR2} {; NL}	###.####
LDOFFV{?}{SP} {NR2} {; NL}	###.####
CC CURR:{A B} {?}{SP} {NR2}{; NL}	###.####
CP:{A B} {?}{SP} {NR2}{; NL}	###.####
CR RES:{A B} {?}{SP} {NR2}{; NL}	###.####
CV VOLT:{A B} {?}{SP} {NR2}{; NL}	###.####
CVI:{A B} {?}{SP} {NR2}{; NL}	###.####
TCONFIG {?} {; NL}	1:NORMAL 5: non-LIN 2:SHORT 6: nocLIN+CR 3:OPP 7:FUSE 4:OCP 8:BATT 9:Trans
OCP: START {?} {; NL}	###.####
OCP: STEP {?} {; NL}	###.####
OCP: STOP {?} {; NL}	###.####
VTH {?} {; NL}	###.####
OPP: START {?} {; NL}	###.####
OPP: STEP {?} {; NL}	###.####
OPP: STOP {?} {; NL}	###.####
STIME {?} {; NL}	###.####
PF {?} {; NL}	###.####
CF {?}{NR2}{; NL}	###.####
OCP {?}	###.####
OPP {?}	###.####
BATT: MODE {?} {; NL}	0~3=CC/LIN/CR/CP
BATT: TIME {?} {; NL}	
EXTIN {?} {; NL}	
TURBO {?} {; NL}	
FUSE: TIME {?} {; NL}	
FUSE: TYPE {?} {; NL}	
FUSE: REP {?} {; NL}	0~255
TRIP: TIME {?} {; NL}	
TRANS: TIME {?} {; NL}	
AVG {?}{; NL}	1 2 4 8 16
CPRSP {?}{; NL}	0~7
CYCLE {?}{; NL}	0~16
ON: ANG {?}{; NL}	+#####
OFF: ANG {?}{; NL}	+#####
REP: COUNT {?}{; NL}	+#####

QUERY PRESET NUMERIC COMMAND	RETURN
BW {?}; NL}	1~15
FREQ {?}; NL}	+###.#
ITIME {?}; NL}	+#####.#
ISTART {?}; NL}	+##.###
ISTEP {?}; NL}	+##.###
ISTOP {?}; NL}	+##.###
SURGE:Tn{?}; NL}	+###.##
SURGE:Sn{?}; NL}	+##.###
SNUB {?}; NL}	

Table 8-4: Remote Control Query Command Syntax - Short Form

8.4.2 Limit Command Syntax

LIMIT COMMAND	RETURN
IH {IL{SP}{NR2}; NL}	
IH {IL {?}; NL}	
WH {WL{SP}{NR2}; NL}	
WH {WL {?}; NL}	###.####
VH {VL{SP}{NR2}; NL}	
VH {VL {?}; NL}	###.####
SVH {SVL{SP}{NR2}; NL}	
SVH {SVL {?}; NL}	###.####
VAH {VAL{SP}{NR2}; NL}	
VAH {VAL {?}; NL}	###.####
OPL {OCL{SP}{NR2}; NL}	Over power limit/Over current limit
OPL {OCL {?}; NL}	###.####

Table 8-5: Remote Control Limit Command Syntax

8.4.3 Stage Commands

STAGE COMMAND	REMARK
LOAD {SP}{ON OFF 1 0}; NL}	
LOAD {?}; NL}	0:OFF 1:ON
MODE {SP}{CC LIN CR CV CP}; NL}	
MODE {?}; NL}	0 1 2 3 4:CC LIN CR CV CP
SHOR {SP}{ON OFF 1 0}; NL}	
SHOR {?}; NL}	0:OFF 1:ON
PRES {SP}{ON OFF 1 0}; NL}	
PRES {?}; NL}	0:OFF 1:ON
SENS {SP}{ON OFF AUTO 1 0}; NL}	
SENS {?}; NL}	0:OFF/AUTO 1:ON
LEV {SP}{LOW HIGH 0 1}; NL}	
LEV {?}; NL}	0:LOW/A
1:HIGH/B	
AFREQ {SP}{ON OFF 1 0}; NL}	AUTO FREQUENCY
AFREQ {?}; NL}	0:OFF 1:ON
CLR; NL}	
ERR {?}; NL}	
NG {?}; NL}	0:GO 1:NG

STAGE COMMAND	REMARK
PROT {?}; NL}	
NGENABLE{SP}{ON OFF}; NL}	
START{; NL}	
STOP{; NL}	
TESTING {?}; NL}	0:TEST END 1:TESTING
SYNC {SP}{ON OFF 1 0} {; NL}	
SYNC {?} {; NL}	0:OFF 1:ON

Table 8-6: Stage Command Syntax

8.4.4 System Commands

COMMAND	NOTE	RETURN
RECALL {SP} {m} {;} NL}	m=1~150 , m:STATE	
STORE {SP} {m} {;} NL}	m=1~150 , m:STATE	
REMOTE {;} NL}	RS232/USB/LAN command	
LOCAL{;} NL}	RS232/USB/LAN command	
NAME {?} {;} NL}		“XXXXXX”

Table 8-7: System Commands Syntax

8.4.5 Measure Commands

COMMAND	RETURN
MEAS:TYPE{SP} {RMS PEAK MAX MIN} {;} NL}	
MEAS:CURREN {?} {;} NL}	###.####
MEAS:VOLT {?} {;} NL}	###.####
MEAS:POW {?} {;} NL}	###.####
MEAS:VAR {?} {;} NL}	###.####
MEAS:VA {?} {;} NL}	###.####
MEAS:V_THD {?} {;} NL}	###.####
MEAS:I_THD {?} {;} NL}	###.####
MEAS:V_HARM {?} {;} NL}	###.####
MEAS:I_HARM {?} {;} NL}	###.####

Table 8-8: Measure Command Syntax

Notes:

1. Current engineering unit: A/Arms
2. Resistance engineering unit: Ω
3. Voltage engineering unit: V/Vrms
4. Period engineering unit: mS
5. Frequency engineering unit: Hz.
6. Power engineering unit: W
7. Volt-Ampere engineering unit: VA

8.4.6 Auto Sequence Commands

AUTO SEQUENCE SET COMMAND	NOTE	RETURN
FILE {SP} {n}{; NL}	n=1~9	1~9
STEP {SP} {n} {; NL}	n=1~16	1~32
TOTSTEP {SP} {n}{; NL}	Total step n=1~16	1~32
SB {SP} {n} {; NL}	LOAD State n=1~150	1~150
TIME {SP} {NR2} {; NL}	100~9999(ms)	100~9999(msec)
SAVE {; NL}	Save "File n" data	
REPEAT {SP} {n} {; NL}	n=0~9999	0~9999
RUN {SP} {F} {n} {; NL}	n=1~9	AUTO REPLY
"PASS" or "FAIL:XX"		
(XX=NG STEP)		
BEEP{SP}{ON OFF}{; NL}	SET BUZZER ON/OFF	

Table 8-9: Auto Sequence Command Syntax

8.5 Command Syntax Tables – Complex Form

The setting and query commands for the loads are listed in the summary tables below. Complex form commands use a longer format syntax.

8.5.1 Setting Commands

SETTING PRESET NUMERIC COMMAND	NOTES
[PRESET:]HARMonics{SP} {NR2} {; NL}	HARMONICS 1~50
[PRESET:]LIN:{A B} {SP} {NR2}{; NL}	
[PRESET:]LDONv{SP} {NR2} {; NL}	
[PRESET:]LDOFfv{SP} {NR2} {; NL}	
[PRESET:]CC CURR:{A B} {SP} {NR2}{; NL}	
[PRESET:]CP:{A B} {SP} {NR2}{; NL}	
[PRESET:]CR RES:{A B} {SP} {NR2}{; NL}	
[PRESET:]CV VOLT:{A B} {SP} {NR2}{; NL}	
[PRESET:]CVI:{A B} {SP} {NR2}{; NL}	CV CURR
[PRESET:]TCONFIG {SP} {NORMAL OCP OPP SHORT NLIN NLCR FUSE BATT TRANS } {; NL}	
[PRESET:]OCP:START {SP} {NR2} {; NL}	
[PRESET:]OCP:STEP {SP} {NR2} {; NL}	
[PRESET:]OCP:STOP {SP} {NR2} {; NL}	
[PRESET:]VTH {SP} {NR2} {; NL}	
[PRESET:]OPP:START {SP} {NR2} {; NL}	
[PRESET:]OPP:STEP {SP} {NR2} {; NL}	
[PRESET:]OPP:STOP {SP} {NR2} {; NL}	
[PRESET:]STIME {SP} {NR2} {; NL}	
[PRESET:]PF {SP} {+ -} {NR2} {; NL}	Power factor
[PRESET:]CF {SP} {NR2} {; NL}	Crest factor
[PRESet:] CF {SP} {NR2}{; NL}	Crest factor
[PRESet:] BATT:MODE {SP} {CC <input type="checkbox"/> LIN <input type="checkbox"/> CV <input type="checkbox"/> CP}{; NL}	
[PRESet:] BATT:TIME {SP} {NR1}{; NL}	
[PRESet:] EXTIN {SP} {ON <input type="checkbox"/> OFF}{; NL}	
[PRESet:] TURBO {SP} {ON <input type="checkbox"/> OFF}{; NL}	
[PRESet:] FUSE: CC{SP}{NR2}{; NL}	
[PRESet:] FUSE: TIME {SP} {NR2}{; NL}	
[PRESet:] FUSE: TYPE {SP} {TRIP NTRIP}{; NL}	
[PRESet:] AVG{SP} {NR2}{; NL}	NR2:1 2 4 8 16
[PRESet:] CPRSP{SP} {NR2}{; NL}	NR2:0~7
[PRESet:] CYCLE{SP} {NR2}{; NL}	NR2:1~16
[PRESet:] ON:ANG{SP} {NR2}{; NL}	0~359
[PRESet:] OFF:ANG{SP} {NR2}{; NL}	0~359
[PRESet:] BW{SP} {NR2}{; NL}	
[PRESet:]FREQ{SP} {NR2}{; NL}	
[PRESet:]ITIME {SP} {NR2}{; NL}	0.1ms~100.0ms
[PRESet:]ISTART {SP} {NR2}{; NL}	
[PRESet:]ISTEP {SP} {NR2}{; NL}	
[PRESet:]ISTOP{SP} {NR2}{; NL}	

SETTING PRESET NUMERIC COMMAND	NOTES
[PRESet:]SURGE:Tn{SP} {NR2}{; NL}	
[PRESet:]SURGE:Sn{SP} {NR2}{; NL}	
[PRESet:]SNUB {SP}AUTO ON OFF{; NL}	

Table 8-10: Remote Control Setting Command Syntax - Complex Form

8.5.2 Query Commands

QUERY PRESET NUMERIC COMMAND	RETURN
[PRESET:]HARMonics{?}{SP} {NR2} {; NL}	###.####
[PRESET:]LIN:{A B}{?} {SP} {NR2}{; NL}	###.####
[PRESET:]LDONv{?}{SP} {NR2} {; NL}	###.####
[PRESET:]LDOFv{?}{SP} {NR2} {; NL}	###.####
[PRESET:]CC CURR:{A B} {?} {SP} {NR2}{; NL}	###.####
[PRESET:]CP:{A B} {?} {SP} {NR2}{; NL}	###.####
[PRESET:]CR RES:{A B} {?} {SP} {NR2}{; NL}	###.####
[PRESET:]CV VOLT:{A B} {?} {SP} {NR2}{; NL}	###.####
[PRESET:]CVI:{A B} {?} {SP} {NR2}{; NL}	###.####
[PRESET:]TCONFIG {?} {; NL}	1:NORMAL 5: non-LIN 2:SHORT 6: noCLIN+CR 3:OPP 7:FUSE 4:OCP 8:BATT 9:Trans
[PRESET:]OCP: START {?} {; NL}	###.####
[PRESET:]OCP: STEP {?} {; NL}	###.####
[PRESET:]OCP: STOP {?} {; NL}	###.####
[PRESET:]VTH {?} {; NL}	###.####
[PRESET:]OPP: START {?} {; NL}	###.####
[PRESET:]OPP: STEP {?} {; NL}	###.####
[PRESET:]OPP: STOP {?} {; NL}	###.####
[PRESET:]STIME {?} {; NL}	###.####
[PRESET:]PF {?} {; NL}	###.####
[PRESET:]CF {?} {NR2} {; NL}	###.####
[PRESet:] OCP {?}{; NL}	
[PRESet:] OPP {?}{; NL}	
[PRESet:] BATT MODE {?}{; NL}	
[PRESet:] BATT TIME {?}{; NL}	
[PRESet:] DISC: TIME {?}{; NL}	
[PRESet:] DISC: AH {?}{; NL}	
[PRESet:] EXTIN {?}{; NL}	
[PRESet:] TURBO {?}{; NL}	
[PRESet:] FUSE: CC {?}{; NL}	
[PRESet:] FUSE: TIME {?}{; NL}	
[PRESet:] FUSE: TYPE {?}{; NL}	
[PRESet:] FUSE: REP {?}{; NL}	
[PRESet:] TRIP: TIME {?}{; NL}	
[PRESet:] TRANS: TIME {?}{; NL}	
[PRESet:] AVG {?}{; NL}	1 2 4 8 16
[PRESet:] CPRSP {?}{; NL}	0~7

QUERY PRESET NUMERIC COMMAND	RETURN
[PRESet:] CYCLE {?}; NL}	0~16
[PRESet:] ON: ANG {?}; NL}	+#####
[PRESet:] OFF: ANG {?}; NL}	+#####
[PRESet:] REP: COUNT {?}; NL}	+#####
[PRESet:] BW {?}; NL}	1~15
[PRESet:] FREQ {?}; NL}	+###.#
[PRESet:] ITIME {?}; NL}	+#####.#
[PRESet:] ISTART {?}; NL}	+##.###
[PRESet:] ISTEP {?}; NL}	+##.###
[PRESet:] ISTOP {?}; NL}	+##.###
[PRESet:] SURGE: Tn{?}; NL}	+###.###
[PRESet:] SURGE:Sn{?}; NL}	+##.###
[PRESet:] SNUB {?}; NL}	

Table 8-11: Remote Control Query Command Syntax - Complex Form

8.5.3 Limit Command Syntax

LIMIT	RETURN
LIMit:CURRent:{HIGH {LOW}{SP}{NR2}; NL}	
LIMit:CURRent:{HIGH {LOW}{?}; NL}	###.####
IH {IL{SP}{NR2}; NL}	
IH {IL {?}; NL}	
LIMit:POWer:{HIGH {LOW}{SP}{NR2}; NL}	
LIMit:POWer:{HIGH {LOW}{?}; NL}	###.####
WH {WL{SP}{NR2}; NL}	
WH {WL {?}; NL}	###.####
LIMit:VOLTag:e:{HIGH {LOW}{SP}{NR2}; NL}	
LIMit:VOLTag:e:{HIGH {LOW}{?}; NL}	###.####
VH {VL{SP}{NR2}; NL}	
VH {VL {?}; NL}	###.####
SVH {SVL{SP}{NR2}; NL}	
SVH {SVL {?}; NL}	###.####
VAH {VAL{SP}{NR2}; NL}	
VAH {VAL {?}; NL}	###.####
OPL {OCL{SP}{NR2}; NL}	Over power limit/Over current limit
OPL {OCL {?}; NL}	###.####

Table 8-12: Remote Control Limit Command Syntax - Complex Form

8.5.4 State Commands

STAGE COMMAND	NOTES
[STATe:] LOAD {SP}{ON OFF} {;} NL}	
[STATe:] LOAD {?} {;} NL}	0:OFF 1:ON
[STATe:] MODE {SP} {CC LIN CR CV CP} {;} NL}	
[STATe:] MODE {?} {;} NL}	0 1 2 3 4:CC LIN CR CV CP
[STATe:] SHORT {SP} {ON OFF} {;} NL}	
[STATe:] SHORT {?} {;} NL}	0:OFF 1:ON
[STATe:] PRESet {SP} {ON OFF} {;} NL}	

STAGE COMMAND	NOTES
[STATe:] PRESet {?} {;} NL}	0:OFF 1:ON
[STATe:] SENSE {SP} {ON OFF AUTO } {;} NL}	
[STATe:] SENSE {?} {;} NL}	0:OFF 1:ON
[STATe:] LEVEL {SP} {A B } {;} NL}	
[STATe:] LEVEL {?} {;} NL}	0:A 1:B
[STATe:] LEV{SP} {A B } {;} NL}	
[STATe:] LEV{?} {;} NL}	0:A 1:B
[STATe:] AUTO:FREQ {SP}{ON OFF} {;} NL}	
[STATe:] AUTO:FREQ {?} {;} NL}	0:OFF 1:ON
[STATe:] CLRerr{;} NL}	
[STATe:] ERRor {?}{;} NL}	
[STATe:] NO{SP}GOOD {?}{;} NL}	
[STATe:] NG {?}{;} NL}	0:GO 1:NG
[STATe:] PROTEct {?}{;} NL}	
[STATe:] NGENABLE{SP}{ON OFF}{;} NL}	
[STATe:]START{;} NL}	
[STATe:]STOP{;} NL}	
[STATe:]TESTING {?}{;} NL}	0:TEST END,1:TESTING
[STATe:] SYNCronize {SP}{ON OFF } {;} NL}	
[STATe:] SYNCronize {?} {;} NL}	0:OFF 1:ON

Table 8-13: Stage Command Syntax - Complex Form

8.5.5 System Commands

COMMAND	NOTE	RETURN
[SYSTem:]RECall {SP} {m} {;} NL}		
[SYSTem:]STORe {SP} {m} {;} NL}	m=1~150	
[SYSTem:]REMOTE {;} NL}	RS232/USB/LAN command	
[SYSTem:]LOCAL{;} NL}	RS232/USB/LAN command	
[SYSTem:]NAME {?} {;} NL}		“XXXXXX”

Table 8-14: System Commands Syntax - Complex Form

8.5.6 Measure Commands

COMMAND	RETURN
MEASure:TYPE{SP} {RMS PEAK MAX MIN} {;} NL}	
MEASure:CURR {?}{;} NL}	###.####
MEASure:VOLT {?}{;} NL}	###.####
MEASure:POW {?}{;} NL}	###.####
MEASure:VAR {?}{;} NL}	###.####
MEASure:VA {?}{;} NL}	###.####
MEASure:V_THD {?}{;} NL}	###.####
MEASure:I_THD {?}{;} NL}	###.####
MEASure:V_HARM {?}{;} NL}	###.####
MEASure:I_HARM {?}{;} NL}	###.####

Table 8-15: Measure Command Syntax - Complex Form

Notes:

1. Current engineering unit: A/Arms
2. Resistance engineering unit: Ω
3. Voltage engineering unit: V/Vrms
4. Period engineering unit: mS
5. Frequency engineering unit: Hz.
6. Power engineering unit: W
7. Volt-Ampere engineering unit: VA

8.6 Remote Control Command Descriptions

The remote control syntax of all available commands is described in the following sections. Supported commands are grouped in the following categories:

Command Category	Description
SETTING (PRESET)	Setting commands are used to program operating modes, sink values and built in test modes like SHORT, OPP and OCP.
LIMIT	Limit commands may be used to set expected upper and lower operating limits as they apply to a unit under test. These limit settings are used in conjunction with Go/NG testing to indicate the load is sinking outside expected parameters.
STATE	State commands are used to query or clear status information from a load to determine its operating condition.
SYSTEM	System commands enable querying of load model number and configuration data, RS232 control on/off. They also support storing and saving load set-ups in non-volatile memory. (15 Banks / 10 States)
MEASUREMENTS	Allows querying load measurement data.
IEEE488.2 COMMANDS	Supported IEEE488.2 Commands (a.k.a. star commands)

8.6.1 Setting Command Descriptions

These command set or query load settings.

HARM

Syntax: [PRESet:] HARM{SP} {NR1} {; | NL}
[PRESet:] HARM{?} {; | NL}

Purpose: Set and read the HARMONICS

Description: Set and read the HARMONICS

LIN

Syntax : [PRESet:] LIN :A|B {SP}{NR2} {; | NL}
[PRESet:] LIN :A|B {?} {; | NL}

Purpose: Set and read the linear current.

Description: Set and read the linear current.

LDONV

Syntax: [PRESet:] LDONV {SP}{NR2} {; | NL}
[PRESet:] LDONV{?} {; | NL}

Purpose: Set and Read the voltage of LOAD ON

Description: This command sets the LOAD ON voltage of 3C Series AC&DC Electronic load.

LDOFFV

Syntax: [PRESet:] LDOFFV{SP}{ NR2}{; | NL}
[PRESet:] LDOFFV {?}{; | NL}

Purpose: Set and read the voltage of LOAD OFF

Description: This command is for setting the Load voltage value of LOAD OFF.

CC|CURR:A|B

Syntax: [PRESet:] CC|CURR:{A|B}{SP}{ NR2} {; | NL}
[PRESet:] CC|CURR:{A|B} {?} {; | NL}

Purpose: Set and read the current of A or B.

Description: This command is for setting the required Load current.

Note:

1. Level A load and Level B load current settings are independent.
2. The unit is A.

CP:{ A|B}

Syntax: [PRESet:] CP:{ A|B}{SP}{ NR2} {; | NL}
[PRESet:] CP: {A|B} {?} {; | NL}

Purpose: Set and read the value of Watt

Description: This command is for setting the required value of Watt, and the unit is W.

CR|RES: {A|B}

Syntax: [PRESet:] CR|RES:{ A|B}{SP}{ NR2} {; | NL}
[PRESet:] CR|RES: { A|B} {?} {; | NL}

Purpose: Set and read the value of Resistance

Description: This command is used for setting the required value of Load Resistance.

Note:

1. Level A load and Level B load resistance settings are independent.
2. The unit is Ω .

CV|VOLT: {A|B}

Syntax: [PRESet:] CV:{A|B} {SP}{ NR2} { ; |NL}
 [PRESet:] CV:{A|B} {?} { ; |NL}
 [PRESet:] VOLT:{ A|B}{SP}{ NR2} { ; |NL}
 [PRESet:] VOLT:{A|B}{?} { ; |NL}

Purpose: Set and read the value of Voltage

Description: This command is for setting the required value of Voltage. The unit is V.

CVI|VOLT :{ A|B}

Syntax: [PRESet:] CVI: {A|B} {SP}{ NR2} { ; |NL}
 [PRESet:] CVI: {A|B} {?} { ; |NL}

Purpose: Set and read the value of Voltage

Description: This command is for setting the required value of Voltage, and the unit is V.

TCONFIG

Syntax: [PRESet:] TONFIG {NORMAL|OCP|OVP|OPP|SHORT|NLIN|NLCR|FUSE|BATT|TRANS}{ ; |NL}
 [PRESet:] TONFIG {?} { ; |NL}

Purpose: Set and read the of test Item

Description: There are nine test mode parameters for this command:

NORMAL mode, OCP test, OPP test, SHORT, NLIN, NLCR, FUSE, BATT, TRANS

OCP: START

Syntax: [PRESet:] OCP:START {SP}{NR2} { ; |NL}
 [PRESet:] OCP:START {?} { ; |NL}

Purpose: Set and read the initial value of OCP test

Description: This command sets the required initial value (I-START) for the OCP test

OCP: STEP

Syntax: [PRESet:] OCP:STEP {SP}{NR2} { ; |NL} [PRESet:] OCP:STEP{?} { ; |NL}

Purpose: Set and read the increasing value of OCP test

Description: This command sets the current step value (I-STEP) for the OCP test

OCP: STOP

Syntax: [PRESet:] OCP:STOP {SP}{NR2} { ; |NL}
 [PRESet:] OCP:STOP {?} { ; |NL}

Purpose: Set and read the maximum value of OCP test

Description: This command sets the maximum value (I-STOP) for the OCP test.

VTH

Syntax: [PRESet:] VTH {SP}{NR2} { ; |NL}
 [PRESet:] VTH {?} { ; |NL}

Purpose: Set and read the value of the Threshold Voltage

Description: This command sets the Threshold Voltage. That is the OCP/OPP of this Load model when the output voltage of appliance is lower or equaled to the VTH.

OPP: START

Syntax: [PRESet:] OPP:START {SP}{NR2} { ; |NL}
 [PRESet:] OPP:START {?} { ; |NL}

Purpose: Set and read the initial value of OPP test

Description: This command sets the initial value (P-START) for the OPP Test

OPP: STEP

Syntax: [PRESet:] OPP:STEP {SP}{NR2} { ; | NL }
[PRESet:] OPP:STEP {?} { ; | NL }

Purpose: Set and read the power step value for the OPP test.

Description: This command sets the power step (P-STEP) for the OPP Test

OPP: STOP

Syntax: [PRESet:] OPP: STOP {SP}{NR2} { ; | NL }
[PRESet:] OPP: STOP {?} { ; | NL }

Purpose: Set and read the maximum value of OPP test

Description: This command sets the maximum value (P-STOP) for the OPP test

STIME

Syntax: [PRESet:] STIME {SP}{NR2} { ; | NL }
[PRESet:] STIME {?} { ; | NL }

Purpose: Set and read time of the short-circuit test

Description: This command sets the time for the short-circuit test. If time set to zero, there is no time limit and the short is continuous. The unit is milli-seconds (ms)

PF

Syntax: [PRESet:] PF {SP}{+|-}{NR2} { ; | NL }
[PRESet:] PF {?} { ; | NL }

Purpose: Set and read Power factor.

Description: This command sets the Power factor. Setting range is 0.01 ~ 1.00.

CF

Syntax: [PRESet:] CF {SP}{NR2} { ; | NL }
[PRESet:] CF {?} { ; | NL }

Purpose: Set and read the crest factor.

Description: This command sets the crest factor. Setting range is 1.4142~5.0.

BATT: MODE

Syntax: [PRESet:] BATT:MODE {SP}{CC|CR|CV|CP|LIN} { ; | NL }
[PRESet:] BATT: MODE {?} { ; | NL }

Purpose: Set and read the Battery test mode.

Description: This command sets or reads the Battery test mode.

BATT: TIME

Syntax:[PRESet:] BATT:TIME {SP} {NR1} { ; | NL }
[PRESet:] BATT: TIME {?} { ; | NL }

Purpose: Set and read the Battery test time.

Description: This command sets or reads the Battery test time. Setting range is 1s ~ 99999s.

DISC: TIME

Syntax: [PRESet:] DISC: TIME {?} { ; | NL }

Purpose: Read the battery discharge time.

Description: This command is used after the test ends and reads the battery discharge time.
Range is 1s ~ 99999s.

DISC:AH

Syntax: [PRESet:] DISC: AH {?} { }; |NL}

Purpose: Read the battery capacity.

Description: This command is used after the test ends and reads the battery capacity.

EXTIN:ON/OFF

*(this function is optional.)

Syntax: [PRESet:] EXTIN: {SP} ON|OFF} { }; |NL}

[PRESet:] EXTIN{?} { }; |NL}

Purpose: Set the external input signal.

Description: This command sets EXTIN to ON or OFF.

TURBO

Syntax: [PRESet:] TURBO{ON|OFF} { }; |NL}

[PRESet:] TURBO {?} { }; |NL}

Purpose: Set and read theTURBO mode (ON or OFF).

Description: In TURBO mode, the output current is double the maximum rated current for a short period.

FUSE:CC

Syntax:[PRESet:] FUSE:CC {SP}{NR2} { }; |NL}

[PRESet:] FUSE: CC {?} { }; |NL}

Purpose: Set and read fuse test current value.

Description: This command sets or reads the fuse test current value. Ranges depend on load model as shown in the table below.

Model	Normal	Turbo
3C018-18	18.74A	37.5A
3C028-18	18.74A	37.5A
3C028-28	28.0A	56.0A
3C038-28	28.0A	56.0A
3C038-38	37.5A	75.0A
3C075-75	75.0 A	150.0 A
3C112-112	112.5 A	225.0 A

FUSE: TIME

Syntax: [PRESet:] FUSE: TIME {SP} }{NR2} { }; |NL}

[PRESet:] FUSE: TIME {?} { }; |NL}

Purpose: Set and read fuse test time.

Description: This command sets or reads the fuse test time. Setting range is 0.1s ~ 9999.9s.

FUSE: TYPE

Syntax: [PRESet:] FUSE:TYPE {SP} }{TRIP|NTRIP} { }; |NL}

[PRESet:] FUSE: TYPE {?} { }; |NL}

Purpose: Set and read fuse type.

Description: This command sets or reads the fuse TRIP or NTRIP state.

FUSE: REP

Syntax:[PRESet:] FUSE:REP {SP} }{NR1} { }; |NL}

[PRESet:] FUSE: REP {?} { }; |NL}

Purpose: Set and read the fuse repeat tests number of times.

Description: This command sets or reads the fuse number of test repeats. Setting range is 0 ~ 255 times.

TRIP: TIME

Syntax: [PRESet:] TRIP: TIME {?};|NL}

Purpose: Rread the fuse fusing time.

Description: This command is when the test end, read the fuse fusing time.

TRANS: TIME

Syntax: [PRESet:] TRANS: TIME {?};|NL}

Purpose: Read UPS Transfer time.

Description: This command is when the test end, read the UPS Transfer time.

AVG

Syntax: [PRESet:] AVG {SP} {NR2};|NL}

[PRESet:] AVG? {;|NL}

Purpose: Set and read back the average 1, 2, 4, 8, and 16.

Description: Set and read back the average 1, 2, 4, 8, and 16, the default is 1 without averaging.

CPRSP

Syntax: [PRESet:] CPRSP {SP} {NR2};|NL}

[PRESet:] CPRSP? {;|NL}

Purpose: Set and read back the CPRSP 0~7. the default is 0.

Description: CPRSP is set to the constant power response speed 0~4 for linear current constant power load, 0 is the fastest to adjust the load power response, 3 is the slowest 4~7 is the standard current constant power load 4 to adjust the load power The response is the fastest, and the slowest default is 0.

CYCLE

Syntax: [PRESet:] CYCLE {SP} {NR2};|NL}

[PRESet:] CYCLE? {;|NL}

Purpose: Set and read back the CYCLE ,can be set from 1 to 16.

Description: The set is 8, that is 8 weeks to do the meter value processing.

BW

Syntax: [PRESet:] BW {SP} {NR2};|NL}

[PRESet:] BW? {;|NL}

Purpose: Set and read the BW 0~15.

Description: Set and read the bandwidth from 0 to 15 bandwidth, 15 is the fastest, and the initial Value is 13.

FREQ

Syntax: [PRESet:] FREQ {SP}{AUTO|NR2};|NL}

[PRESet:] FREQ? {;|NL}

Purpose: Set and read the frequency .

Description: Set and read the frequency range from 40 to 800 Hz.

REP: COUNT

Syntax: [PRESet:] REP: COUNT? {;|NL}

Purpose: use fuse test.

Description: Read the number of repeated tests.

8.6.2 Limit Command Descriptions

LIMIT commands are used to set high and low operating limits that can be used in conjunction with the Go / NoGo (NG) function to signal that the load is sinking outside the expected parameters.

[LIMit:]CURRent:{ HIGH|LOW} or IH|IL

Syntax: [LIMit]:CURRent:{ HIGH|LOW}{SP}{ NR2 }{;}|NL}
 [LIMit]:CURRent:{ HIGH|LOW} {?}{;}|NL}
 [IH|IL]{SP}{NR2}{;}|NL}
 [IH|IL] ?{;}|NL}

Purpose: To set the upper/lower limit value of threshold current.

Description: This command sets the lower limit value of threshold current. When the load sink current is lower than the lower limit value or higher than the upper limit value, the NG indicator light will come on to indicate “NO GOOD”.

[LIMit:]POWer:{ HIGH|LOW} or WH|WL

Syntax: [LIMit]:POWer:{ HIGH|LOW}{SP}{ NR2 }{;}|NL}
 [LIMit]:POWer:{ HIGH|LOW} {?}{;}|NL}
 [WH|WL]{SP}{ NR2 }{;}|NL}
 [WH|WL]?{;}|NL}

Purpose: To set the upper/lower limit value of threshold power (W).

Description: This command sets the upper/lower limit value of threshold power (WATT). When the power (WATT) is lower than the lower limit value or higher than the upper limit value, the NG indicator light will come on to indicate “NO GOOD”.

[LIMit:] VOLTage:{ HIGH|LOW} or VH|VL

Syntax: [LIMit] VOLTage:{ HIGH|LOW}{SP}{ NR2 }{;}|NL}
 [LIMit] VOLTage:{ HIGH|LOW} {?}{;}|NL}
 [VH|VL]{SP}{ NR2 }{;}|NL}
 [VH|VL]?{;}|NL}

Purpose: To set the upper/lower limit value of threshold voltage.

Description: This command sets the upper/lower limit value of threshold voltage. When the input voltage is lower than the lower limit value or higher than the upper limit value, the NG indicator light will come on to indicate “NO GOOD”.

[LIMit:] {SVH|SVL}{

Syntax: [LIMit:] {SVH|SVL}{SP}{ NR2 }{;}|NL}
 [LIMit:] { SVH|SVL} {?}{;}|NL}

Purpose: To set the upper/lower limit value of short current.

Description: This command sets the upper/lower limit value of short current. When the short current is lower than the lower limit value or higher than the upper limit value, the NG indicator light will come on to indicate “NO GOOD”.

8.6.3 State Command Descriptions

STATE commands can be used to set or query the actual operating status of the electronic load at any time.

[STATE:] LOAD {SP}{ON | OFF}

Syntax: [STATE:] LOAD {SP}{ON | OFF}; | NL
[STATE:] LOAD {?}; | NL

Purpose: Set and read the status of Sink Current or not

Description: This command is used to set the Sink Current status. When ON, the Load is going to sink current from equipment under test (EUT). When OFF, the Load is in a high impedance input state.

[STATE:] MODE {SP}{CC | CR | CV | CP}

Syntax: [STATE:] MODE {SP}{CC | CR | CV | CP}; | NL
[STATE:] MODE {?}; | NL

Purpose: Set and read the mode of LOAD

Description: The load is operating in one of these four modes shown in the table below. When reading the Load Operation mode, the return values 0 | 1 | 2 | 3 | 4 represent CC | LIN | CR | CV | CP respectively.

Mode	CC	LIN	CR	CV	CP
(value)	0	1	2	3	4
3C load	V	V	V	V	V

[STATE:] PRESet {SP}{ON | OFF}

Syntax: [STATE:] PRESet {SP}{ON | OFF}; | NL
[STATE:] PRESet {?} {?}; | NL

Purpose: Set the left or right digit multi-function meter to display the programming load level.

Description: This command selects the left 5-digit LCD display to show current setting or power meter.

1. Pres ON: To select the LCD display to show the current setting.
2. Pres OFF: To select the LCD Display to show the power read back.

[STATE:] SENSE{SP}{ON | OFF }

Syntax: [STATE:] SENSE{SP}{ON | OFF }; | NL
[STATE:] SENSE {?} {?}; | NL

Purpose: Set and read the Load voltage to read whether is carried by the VSENSE or not.

Description: This command is used to set the Load voltage sense mode to internal or external sense. When ON, VSENSE takes place at the VSense connection. When off, Vsense takes place at the INPUT Connector to the load.

[STAtE:] LEVEl {SP}{A | B} or LEV {SP}{A | B}

Syntax: [STAtE:] LEVEl {SP}{A | B }{; | NL}

[STAtE:] LEVEl {?} {; | NL}

[STAtE:] LEV{SP}{A | B}{; | NL}

[STAtE:] LEV{?} {; | NL}

Purpose: Set and read the A and B of Load

Description: LEV LOW is the low-level value for:

1. Current in CC mode
2. Resistance on CR mode
3. Voltage on CV mode
4. Power on CP mode.

[STAtE:] AUTO: FREQ {SP}{ON | OFF}

Syntax: [STAtE:] AUTO: FREQ {SP}{ON|OFF}{; | NL}

[STAtE:] AUTO: FREQ {?} {; | NL}

Purpose: Set and read the electronic load frequency ON or OFF

Description: This command sets or reads the electronic load frequency ON or OFF (0: OFF 1: ON).

[STAtE:] CLRerr

Syntax:[STAtE:] CLRerr {; | NL}

Purpose: Clear the error flag of the load during operation.

Description: This command clears the contents of the PROT and ERR registers. After sending this command, the contents of these two registers will be “0”.

[STAtE:] ERRor

Syntax:[STAtE:] ERRor {?} {; | NL}

Purpose: Reads the status register value.

Description: This query only command returns the load status.

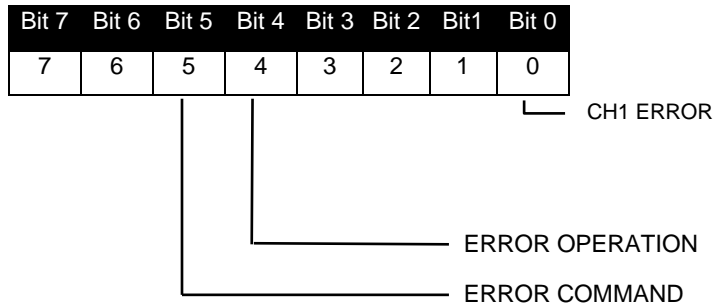

BIT ID	BIT VALUE	REMARK
bit 0-3	0 = Off, 1 = Triggered	CH1 error
bit 4	0 = Off, 1 = Triggered	Operation error
bit 5	0 = Off, 1 = Triggered	Command error (e.g. syntax error)

[STATE:] NG?

Syntax: [STATE:] NG {?}; | NL}

Purpose: Query the NG test flag.

Description: Sets command NG? to show the NG status. When set to “0”, the NG (NO GOOD) LCD will be off. When set to ”1”, the NG (NO GOOD) LCD will be lit.

[STATE:] PROTECT?

Syntax: [STATE:] PROTECT {?}; | NL}

Purpose: Query if there have protection flag which had been set in this 3270 Series

Description:

- PROT? Means the Protection status. A “1” means OPP occurred, a ”4” means OVP, an “8” means OCP. The table below shows the corresponding number of protection status.
- Use command CLR to clear the register of PROT status to be “0”

Bit 7	Bit 6	Bit 5	Bit 4	Bit 3	Bit 2	Bit1	Bit 0
64	32	16	8	4	2	1	0

BIT ID	BIT VALUE	REMARK
bit 0	0 = Off, 1 = Triggered	Over Power Protection (OPP)
bit 1	0 = Off, 1 = Triggered	Over Temperature Protection (OTP)
bit 2	0 = Off, 1 = Triggered	Over Voltage Protection (OVP)
bit 3	0 = Off, 1 = Triggered	Over Current Protection (OCP)

[STATE:] NGEABLE {ON | OFF}

Syntax: [STATE:] NGEABLE {ON | OFF} {; | NL}

Purpose: To enable or disable the GO/NG function check state.

Description: Sets the function of NG function check when POWER ON. When set for POWER OFF, the NG determination will not be implemented.

[STATE:] START

Syntax: [STATE:]START {; | NL}

Purpose: Set for Load to implement the test.

Description: Sets the Load to execute the test according to the TEST CONFIG (TCONFIG). The load will start to test the required items and parameters.

[STATE:] STOP

Syntax: [STATE:] STOP {; | NL}

Purpose: Set the load to stop the test

Description: Stops the test

[STATE:] TESTING?

Syntax: [STATE:]TESTING {?} {; | NL}

Purpose: Checks whether the load is in the test state.

Description: Check whether the load is in the test state: 1 = testing, 0 = Test end.

Example:

```
START
TESTING?
NG?
STOP
```

[STATe:] SYNCronize

Syntax: [STATe:]SYNCronize {SP}{ON | OFF} {;} | NL}
[STATe:]SYNCronize {?} {;} | NL}

Purpose: Set or read load sync signal enable state.

Description: load sync signal settings: 1: SYNC ON 0: SYNC OFF

8.6.4 System Command Descriptions

[SYStem:] RECall{ SP }m{ ,n }

Syntax: [SYStem:] RECall{ SP }m{;} | NL}

Purpose: Recall load settings saved in memory.

Description: This command recalls the load settings from memory location m (STATE).m = 1~150

For Example:

RECALL 2 → Recall the load settings saved in the memory location 2.

[SYStem:] STORe{SP}m{n}

Syntax:[SYStem:] STORe{SP}m{;} | NL}

Purpose: Save the load settings to memory

Description: This command is for saving the status of Loading to the Memory.m (STATE). m = 1~150.

For Example:

SAVE 2 → Save the load settings to memory location 2.

[SYStem:] NAME?

Syntax: [SYStem:] NAME {?} {;} | NL}

Purpose: Read the model number of Load

Description: This command reads the model number of Load. The front panel display will show the model number as well. Models: 3C018-18 through 3C112-112.

[SYStem:] REMOTE

Syntax: [SYStem:] REMOTE {;} | NL}

Purpose: Enters the REMOTE status (only applies to USB, LAN or RS232 communication)

Description: This command enables the remote state of the load.

[SYStem:] LOCAL

Syntax: [SYStem:] LOCAL {;} | NL}

Purpose: Exits the REMOTE status (only applies to USB, LAN or RS232 communication)

Description: This command enables the local state of the load.

8.6.5 Measurement Command Descriptions

Measurement commands allow measurement data to be retrieved.

MEASure:CURRent?

Syntax: MEASure:CURRent{?}; | NL}

Purpose: Read the current measurement.

Description: This command reads the five digits of the current meter. Unit is Amperes (A).

MEASure:VOLTage?

Syntax: MEASure:VOLTage{?}; | NL}

Purpose: Read the voltage measurement.

Description: This command reads the five digits of the volt meter. Unit is Volts (V).

MEASure:POWer?

Syntax: MEASure:POWer{?}; | NL}

Purpose: Read the power measurement.

Description: This command reads the five digits of the power meter. Unit is Watts (W).

MEASure:VAR?

Syntax: MEASure:VAR {?}; | NL}

Purpose: Read the reactive power measurement.

Description: This command reads the five digits of the reactive power meter. Unit is VA (VA).

MEASure:VA?

Syntax: MEASure:VA {?}; | NL}

Purpose: Read the apparent power measurement.

Description: This command reads the five digits of the apparent power meter. Unit is VA

MEASure:V_THD?

Syntax: MEASure:V_THD {?}; | NL}

Purpose: Read the Voltage harmonic distortion measurement.

Description: This command reads the Voltage harmonic distortion.

MEASure:I_THD?

Syntax: MEASure:I_THD {?}; | NL}

Purpose: Read the current harmonic distortion measurement.

Description: This command reads the current harmonic distortion.

MEASure:V_HARM?

Syntax: MEASure: V_HARM {?}; | NL}

Purpose: Read the Voltage harmonic distortion measurement.

Description: This command reads the Voltage harmonic distortion.

MEASure:I_HARM?

Syntax: MEASure:I_HARM {?}; | NL}

Purpose: Read the current harmonic measurement.

Description: This command reads the current harmonic distortion.

8.7 Test Mode Commands

The commands described in this section allow remote control operation of the following test modes:

- OCP Over Current Protection testing
- OCP Over Current Protection testing
- SHORT CIRCUIT Short Circuit testing

8.7.1 OCP Test Mode Commands

REMOTE	COMMAND
OCP:TCONFIG OCP	Set OCP test
OCP:START 0.1	Set start load current 0.1A
OCP:STEP 0.01	Set step load current 0.01A
OCP:STOP 2	Set stop load current 2A
OCP:VTH 3.0	Set OCP VTH 3.0V
OCP:IL 0	Set current low limit 0A
OCP:IH 2	Set current high limit 2A
OCP:NGENABLE ON	Set NG Enable ON
OCP:START	Start OCP testing
OCP:TESTING?	Query Testing? 1: Testing, 0: Testing Ended
OCP:NG?	Query PASS/FAIL?, 0: PASS, 1: FAIL
OCP?	Query OCP current value
OCP:STOP	Stop OCP testing

8.7.2 OPP Test Mode Commands

REMOTE	COMMAND
OPP:TCONFIG OPP	Set OCP test
OPP:START 3	Set start load watt 3W
OPP:STEP 1	Set step load watt 1W
OPP:STOP 5	Set stop load watt 5W
OPP:VTH 3.0	Set OPP VTH 3.0V
OPP:WL 0	Set watt low limit 0W
OPP:WH 5	Set watt high limit 5W
OPP:NGENABLE ON	Set NG Enable ON
OPP:START	Start OPP testing
OPP:TESTING?	Query Testing? 1: Testing, 0: Testing Ended
OPP:NG?	Query PASS/FAIL? 0: PASS, 1: FAIL
OPP?	Query OPP watt value
OPP:STOP	Stop OPP testing

8.7.3 Short Circuit Test Mode Commands

REMOTE	COMMAND
TCONFIG SHORT	Set SHORT test
SHORT:STIME 1	Set short time 1ms
SHORT:START	Start SHORT testing
SHORT:TESTING?	Query Testing? 1: Testing, 0: Testing Ended
SHORT:STOP	Stop SHORT testing

8.8 IEEE488.2 Common Commands

The following IEEE488.2 common commands (a.k.a. star commands) are supported by the load.

8.8.1 *ESE

Command Syntax:

*ESE{?} {; | NL}

Purpose: Sets the Event Status Event Enable register value. Setting a bit indicates the corresponding event will trigger a service request. The bit configuration for the ESE register is shown below.

Query Format: Returns the Event Status Event Enable register value. Reading the register clears it.

Query response: {NR2}

See also: STATE:ERRor?, *ESR? And *STB?

ESE Register - Bit Configuration

Position	bit 7	bit 6	bit 5	bit 4	bit 3	Bit 2	bit 1	bit 0
Name	PON	unused	CME	EXE	DDE	QYE	unused	OPC
Value	128	-	32	16	8	4	2	1

Bit Definitions:

BIT ID	BIT VALUE	REMARK
bit 0	0 = disabled, 1 = enabled	Operation Complete
bit 1	n/a	Not used
bit 2	0 = disabled, 1 = enabled	Query Error
bit 3	0 = disabled, 1 = enabled	Device Dependent Error
bit 4	0 = disabled, 1 = enabled	Execution Error
bit 5	0 = disabled, 1 = enabled	Command Error
bit 6	n/a	Not used
bit 7	0 = disabled, 1 = enabled	Power On

Table 8-16: Event Status Enable Register

8.8.2 *ESR?

Command Syntax:

*ESR? {; | NL}

Purpose: Returns the Event Status Event register. Reading the register clears it. The bit configuration for the ESR register is identical to that of the ESE register. Refer to the tables shown under the *ESE? Command description above.

Query Format: Only the query format of this command exists. Reading the register clears it.

Query response: {NR2}

See also: STATE:ERRor?, *ESE And *STB?

8.8.3 *IDN?

Command Syntax:

*IDN? {; | NL}

Purpose: Returns the load Identity string.

Description: This command is similar to the MODEL command but returns the response in a SCPI format. The response contains four fields separated by a comma.

Query response: Manufacturer, model number, mainframe firmware revision, load controller firmware revision.

Example: APS,3C038-38,1.0,1.00

8.8.4 *OPC

Command Syntax:

*OPC {?} {; | NL}

Purpose: This command sets the OPC bit (bit 0) of the Standard Event Status register when the load has completed all pending operations. (See *ESE for the bit configuration of the Standard Event Status registers.)

Description: Pending operations are complete when all commands sent before *OPC have been executed. This includes overlapped commands. Most commands are sequential and are completed before the next command is executed. The *OPC 1 command must be part of the same message with the command for which the OPC status is requested.

Query format: The query causes the interface to place an ASCII "1" in the Output Queue when all pending operations are completed.

Query response: {NR2}

8.8.5 *RST

Command Syntax:

*RST {; | NL}

Purpose: The *RST command (reset) has the same effect as an IEEE-488 Device Clear bus command but can be used over the RS232C interface as well. This command resets the load to its power on default state.

8.8.6 *SRE

Command Syntax:

*SRE {?} {; | NL}

Purpose: This command sets the condition of the Service Request Enable Register.

Description: This register determines which bits from the Status Byte Register (see *STB for its bit configuration) are allowed to set the Master Status Summary (MSS) bit and the Request for Service (RQS) summary bit. A 1 in any Service Request Enable Register bit position enables the corresponding Status Byte Register bit and all such enabled bits then are logically OR-ed to cause bit 6 of the Status Byte Register to be set.

When the IEEE-488 BUS controller conducts a serial poll in response to SRQ, the RQS bit is cleared, but the MSS bit is not. When *SRE is cleared (by programming it with 0), the load cannot generate an SRQ to the controller.

Query format: The query format returns the Service Request Enable Register value.

Query response: {NR2}

8.8.7 *STB?

Command Syntax:

*STB? {; | NL}

Purpose: Returns the Status Byte register. Reading the Status Byte register **DOES NOT CLEAR IT**. The bit configuration for the Status Byte register is shown in the table below.

Description: This query reads the Status Byte register, which contains the status summary bits and the Output Queue MAV bit. Reading the Status Byte register does not clear it. The input summary bits are cleared when the appropriate event registers are read. A serial poll also returns the value of the Status Byte register, except that bit 6 returns Request for Service (RQS) instead of Master Status Summary (MSS). A serial poll clears RQS, but not MSS. When MSS is set, it indicates that the load has one or more reasons for requesting service.

Query Format: Only the query format of this command exists.

Query response: {NR2}

See also: STATE:ERRor?, *ESE and *ESR?

STB Register - Bit Configuration

Position	bit 7	bit 6	bit 5	bit 4	bit 3	Bit 2	bit 1	bit 0
Name	OPER	MSS RQS	ESB	MAV	QUES	unused	unused	unused
Value	128	-	32	16	8	4	2	1

Bit Definitions:

BIT ID	REMARK
bit 0 - 2	Not used
bit 3	Questionable Status Summary Bit
bit 4	Message Available Bit
bit 5	Event Status Summary Bit
bit 6	Master Status Summary, Request for Service
bit 7	Operation Status Summary Bit

Table 8-17: Status Byte Register

9 Master / Slave Mode Configuration

9.1 Overview

When the maximum power level of a single 3C Series electronic load is insufficient to handle an application or a multi-phase AC load is required, the user can combine two or more 3C Series loads in either parallel or multi-phase mode of operation using its Master / Slave modes. The Master / Slave mode allows the user to interact only with a single Master 3C Load. This includes both programming and measurements which are scaled and summed as needed to make the Master appear as either a higher power load (Parallel Mode) or a three phase load (3-Phase mode). This section explains how to set up, configure and use the load in these modes of operation.

9.2 Parallel (Boost) Mode

In parallel or boost mode, the total current is shared by the number of loads used. This type of connection will expand the power and current of the electronic load. Either two or three loads can be used for parallel Master/Slave mode. (1 Master + 1 Slave or 1 Master + 2 Slaves). The Master load will share the current or power set value for each load automatically. The Master load Amp meter will show total current for all loads combined. The Slave units will show their individual currents just like a single load would.

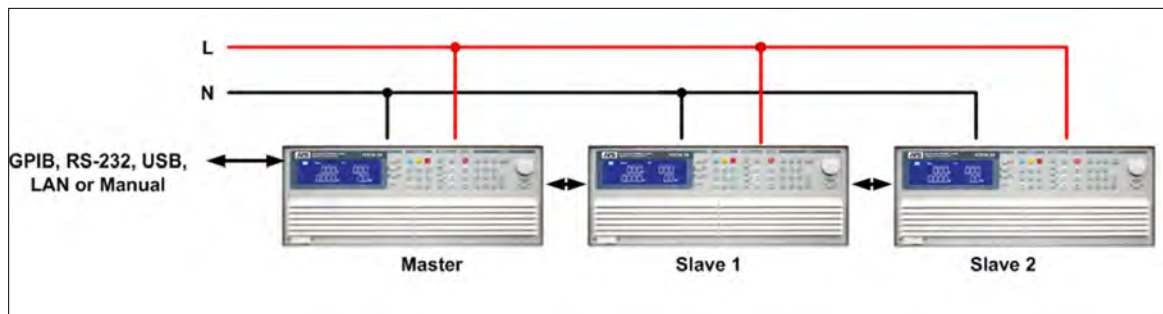

Figure 9-1: Parallel Load Connection

9.3 Multi-Phase Mode

Multi-phase AC test applications are quite common for avionics and shipboard AC power supplies or for higher power commercial applications. This requires one AC load per phase.

Note: External Sync mode is not recommended for multi-phase applications unless individual sync signals can be provided for each phase voltage. Do not use a single external sync signal to drive all loads in a multi-phase application.

There are two possible configurations for 3 phase loads:

Wye Connection: Also known as star connection or four wire plus ground. This requires a Common or Neutral connection on the AC power source.

Delta Connection: AC loads are connected between line-to-line voltages.

Note: Delta connections typically operate at higher voltages than Wye connections as they put the Line-to-Line voltage across the AC load input. Pay attention to the maximum voltage rating of the AC load when using them in this application.

9.3.1 Wiring diagrams for Three Phase AC Load Configurations

In Master/Slave 3-Phase mode, the settings for current or power for each phase will be sent to each Slave unit automatically. The user does not have to set these for each phase unit.

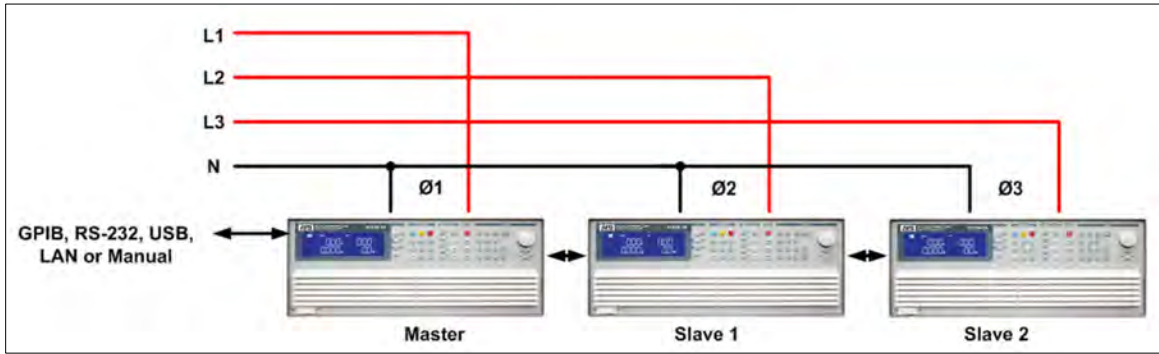

Figure 9-2: Three Phase Wye Connection

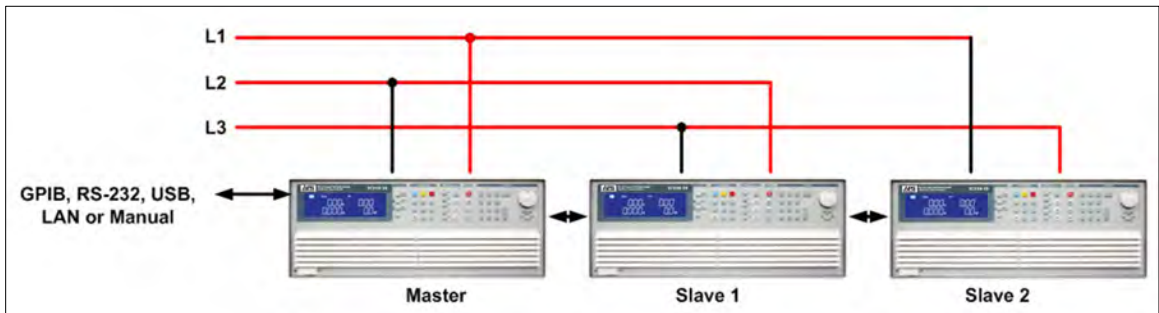

Figure 9-3: Three Phase Delta Connection

9.3.2 Input Configuration Mode Switch Options (**Discontinued**)

NOTE: This Option has been discontinued and is no longer available.

To facilitate switching between delta, Wye and Single Phase AC Input load configurations, two switch options are available for the 3C Series. These MODE options are installed at the bottom of a 3C Load 19" Cabinet and allow manual switching between these three modes.

- Option MODE4 supports three phase systems up to 7,500VA
- Option MODE8 supports three phase systems up to 22,500VA

A three load cabinet with MODE4 option is shown in

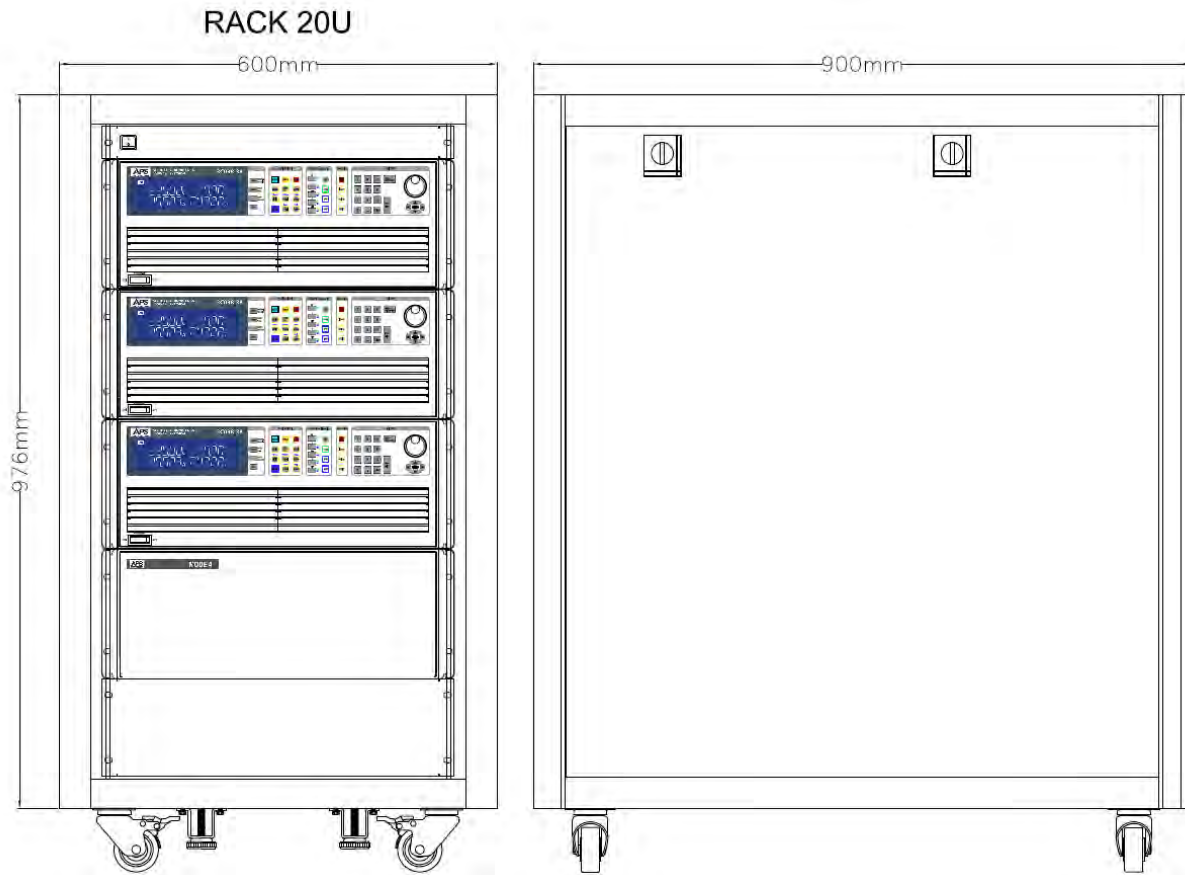

Figure 9-4: Discontinued - Three Phase AC Load Cabinet with MODE4 Switch Option

The rear of the load cabinet is closed off by a screen to allow air flow but is also shown with the screen removed in the figure below.

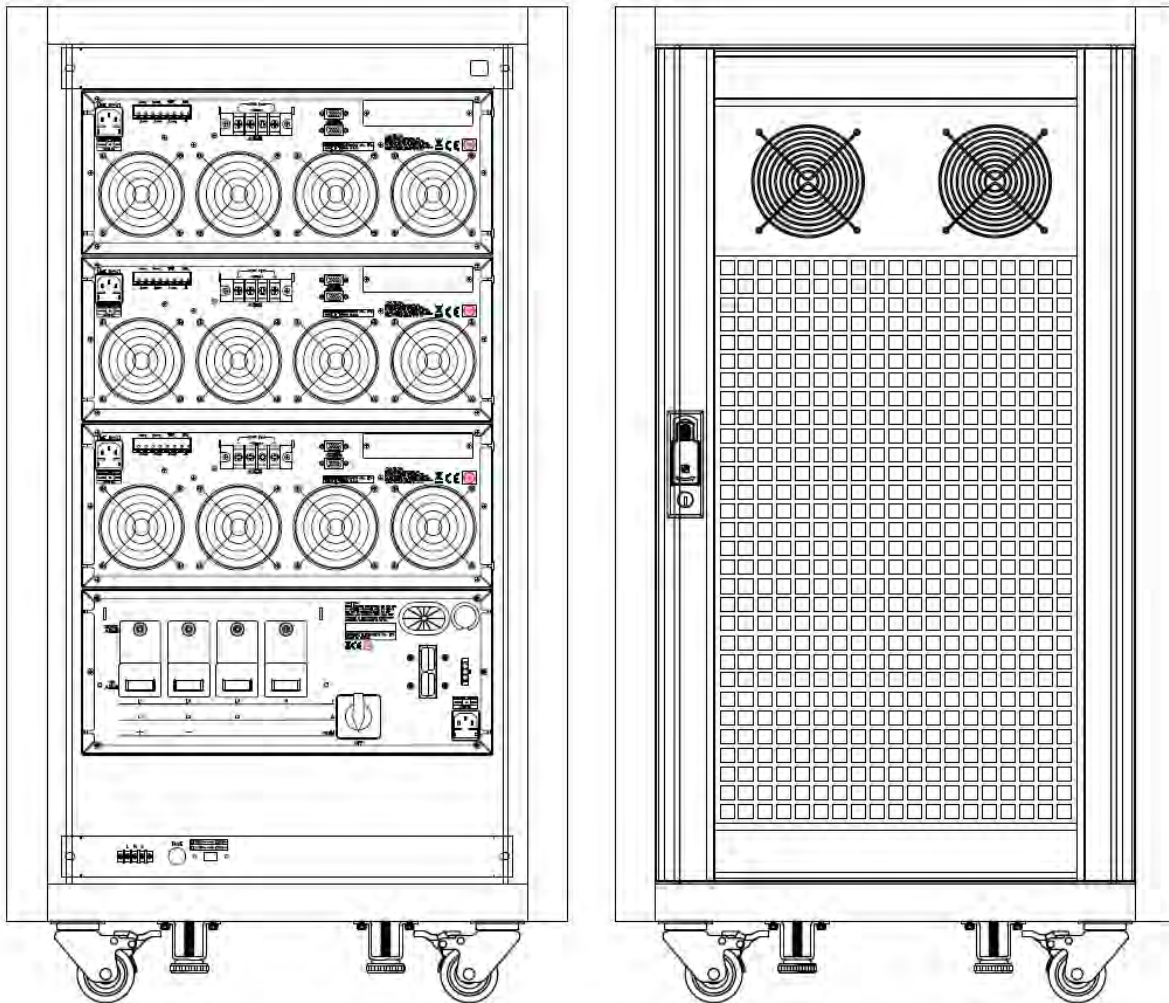

Figure 9-5: Discontinued - Three Phase AC Load Cabinet Rear View

9.4 System Bus Connections

Master/Slave configuration require interconnection of the system bus to allow control of the Slave unit(s) by the Master controller. The System bus connector are located on the rear panel and consist of a set of two, DB15 connectors.

The connectors are used to daisy change the master unit to one or two slave units.

Note: DO NOT use a VGA cable to connect the system bus between units a VGA Monitor cables have pins 4, 8 and 11 shorted to chassis ground. Use the included cable from the ship kit.

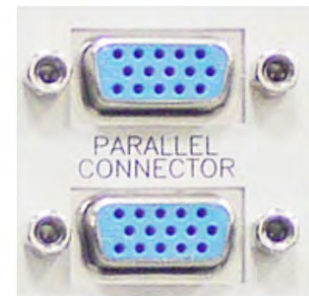

9.4.1 Connections

Use a straight-through DB15-Male to Male cable of sufficient length (5 ft or less) to connect the upper master system bus connector to the upper connector on Slave 1. If there are two slaves, connect the second system bus connectors on Slave 1 to the top connector on Slave 2. Keep the interconnect cables as short as possible.



9.4.2 Suggested system bus cables are:

For stacked units in a 19" cabinet, use a 30 cm / 1 foot cable length. For units positioned next to each other on a bench, use a 150 cm / 5 feet cable length.

Premium Molded D-Sub Cable, HD15 Male / Male, 2.5 ft

<http://www.l-com.com/d-sub-premium-molded-black-d-sub-cable-hd15-male-male-25-ft>

Premium Molded D-Sub Cable, HD15 Male / Male, 5.0 ft

<http://www.l-com.com/d-sub-premium-molded-black-d-sub-cable-hd15-male-male-50-ft>

9.5 Configuring Master / Slave Mode

Configuration for "MASTER / SLAVE" mode depends on the desired mode of operation.

9.5.1 Parallel or Boost Mode

For Parallel mode setup, press the **SYSTEM** key.

The select the control mode and select the following parameters:

CTRL:

- Set to **MASTE bBOOST** on the master unit, and Slave on the slave unit(s). Press **ENTER** to set.
- Set to **SLAVE 1** (or 2) on the slave unit(s). Press **ENTER** to set.
- The mode will be saved and recalled when the loads are turned on.

The Master will automatically detect whether there is a Slave load. If not, it will run in "ALONE Mode".

The Master load measures total current and power meter is to show the total current and for all units. It also displays the voltage measurement.

The Slave load(s) voltage meter position will display "SL1" and "SL2".



9.5.2 Three-Phase Modes

For Three-Phase mode setup, press the **SYSTEM** key. The select the control mode and select the following parameters:

CTRL:

- Set to **MASTE, 3Ph** on the master unit, and Slave on the slave unit(s). Press **ENTER** to set.
- Set to **SLAVE 1** (or 2) on the slave unit(s). Press **ENTER** to set.
- The mode will be saved and recalled when the loads are turned on.

The Master will automatically detect whether there is a Slave load. If not, it will run in "ALONE Mode".

The Master load measures total current and power meter is to show the total current and for all units. It also displays the voltage measurement.

The Slave load(s) voltage meter position will display "SL1" and "SL2".



In three phase Δ or Y connection, the programmed current value (single-phase current value) will be sent to each slave unit automatically, the user does not have to program each unit.

9.6 Example of Setups for Parallel or Boost mode

This example sets the Master/Slave Parallel systems up with the following PRESET CC / LIN / CR / CP Modes:

CC setting 30A

Master = 30A, Slave 1 = 10A, Slave 2 = 10A



Figure 9-6: Parallel / Boost CC Mode Setup

LIN setting 30A

Master = 30A, Slave 1 = 10A, Slave 2 = 10A



Figure 9-7: Parallel / Boost LIN Mode Setup

CR setting: 800Ω

Master = 800Ω, Slave1 = 2400Ω, Slave2 = 2400

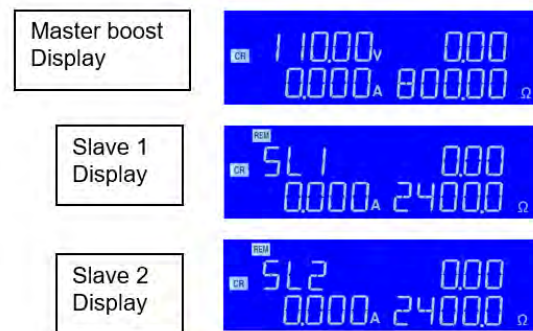

CP setting: 9900W

Master = 9900W, Slave 1 = 3300W, Slave 2 = 3300W

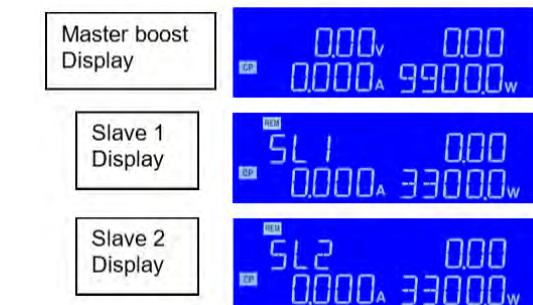

9.7 Example of setups for 3-Phase system.

This example sets the Master/Slave 3-Phase systems up with the following PRESET CC / LIN / CR / CV / CP Modes:

CC setting: 30 A

Master = 30A, Slave 1 = 30A, Slave 2 = 30A

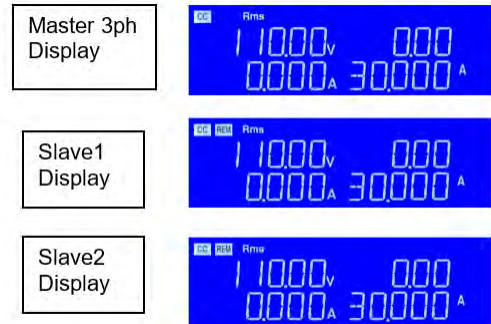

Figure 9-8: 3-PHS CC Settings

LIN setting: 30A

Master = 30A, Slave 1 = 30A, Slave 2 = 30A



Figure 9-9: 3-PHS LIN Settings

CR setting: 3.666Ω

Master = 3.666Ω, Slave 1 = 3.666Ω, Slave2 = 3.666Ω

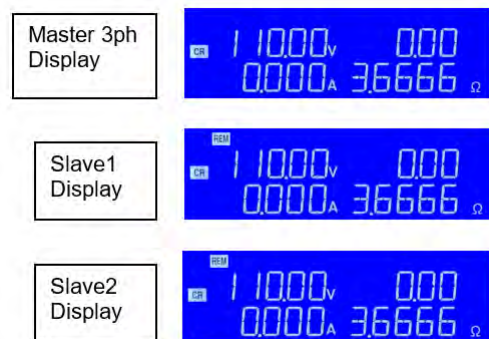

Figure 9-10: 3-PHS CR Settings

CP setting: 3300W

Master = 3300W, Slave 1 = 3300W, Slave 2 = 3300W,

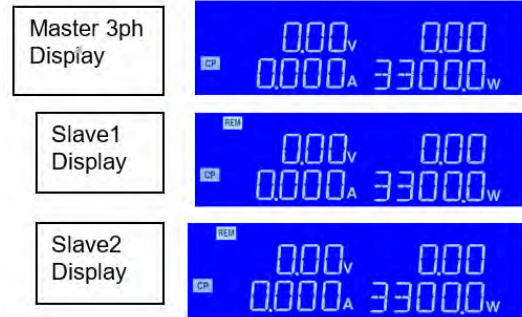

Figure 9-11: 3-PHS CP Settings

CV setting: 100V

Master = 110V, Slave 1 = 110V, Slave 2 = 110V.

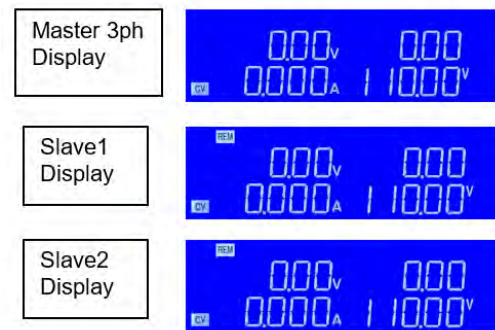

Figure 9-12: 3-PHS CV Settings

9.8 Power ON and OFF Sequence

Use the following procedure when applying power to a Master/Slave system (Power ON):

1. Turn on (O) the Slave POWER switch.
2. Turn on (O) the Master POWER switch.

Use the following procedure when turning off power to a Master/Slave system (Power OFF):

1. Turn off (I) the Master POWER switch.
2. Turn off (I) the Slave POWER switch

9.9 Functions not available in M/S Modes

The following features or functions are disabled while in Master/Slave mode:

- Recall/Store Disable.
- Auto Seq. Disable.
- Short, OCP, OPP Disable

10 USB Driver Installation

10.1 Overview

The load may be equipped with a USB interface. To communicate with this interface, a USB device driver is required on a Windows PC. This appendix describes the driver installation process for the PL-2303 USB to Serial Driver. Once installed, the USB port will appear as a COM port to the Windows Operating System.

10.2 Download USB Driver Archive File

The USB driver for APS loads is available from the Technical Resources page on the Adaptive Power Website. Registration is required but access is granted via email reply immediately.

<https://tr.adaptivepower.com>

Download the APS Load USB Driver Install zip file as indicated in the figure below.

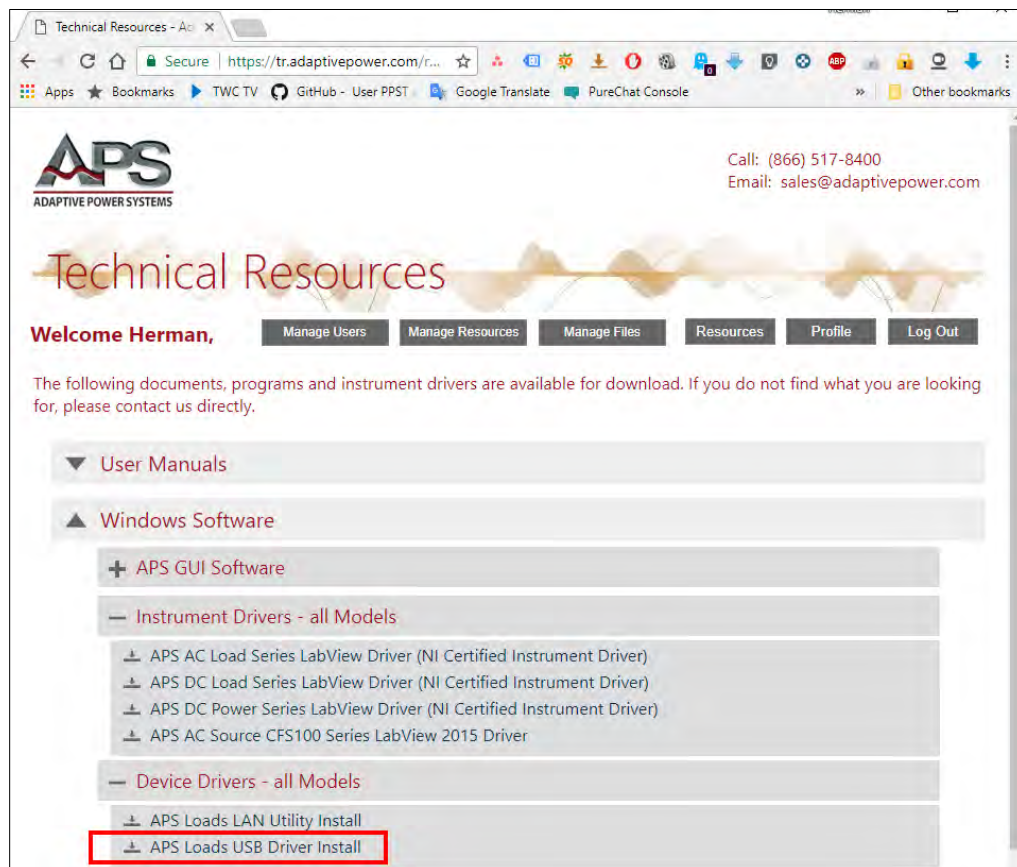

Figure 10-1: USB Device Driver Download

The file name is **APS_LOAD_DRVR-USB.zip**. This compressed archive contains the driver installation program.

10.3 USB Driver Installation

To install the USB device driver, proceed as follows:

1. Insert the supplied CD ROM into a CD Rom drive.
2. If configured for auto-start, the driver installation program will launch. If not, run “USB\SETUP\PL-2303 Driver Installer.exe” from the CD Rom drive.
3. This will open the first installation wizard screen.

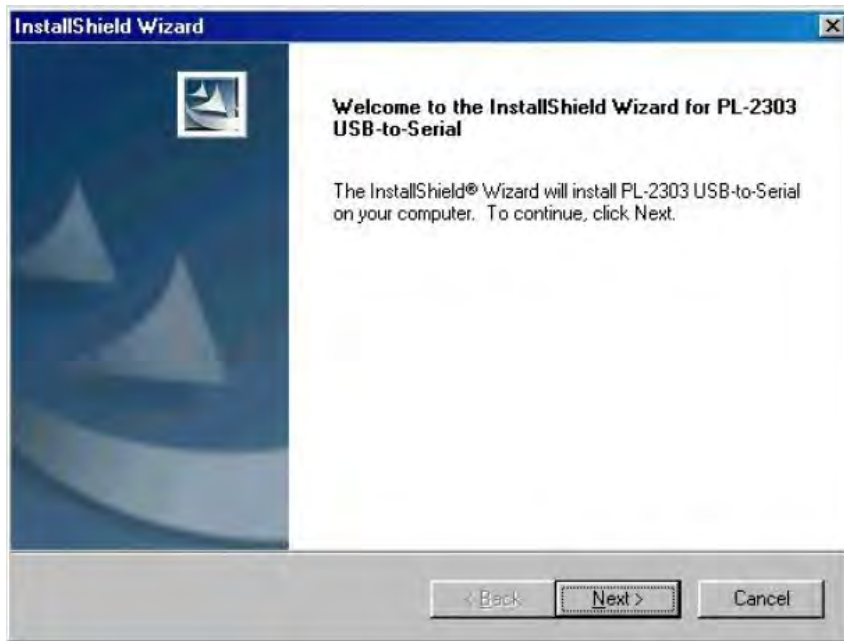

4. Follow the on-screen prompts.

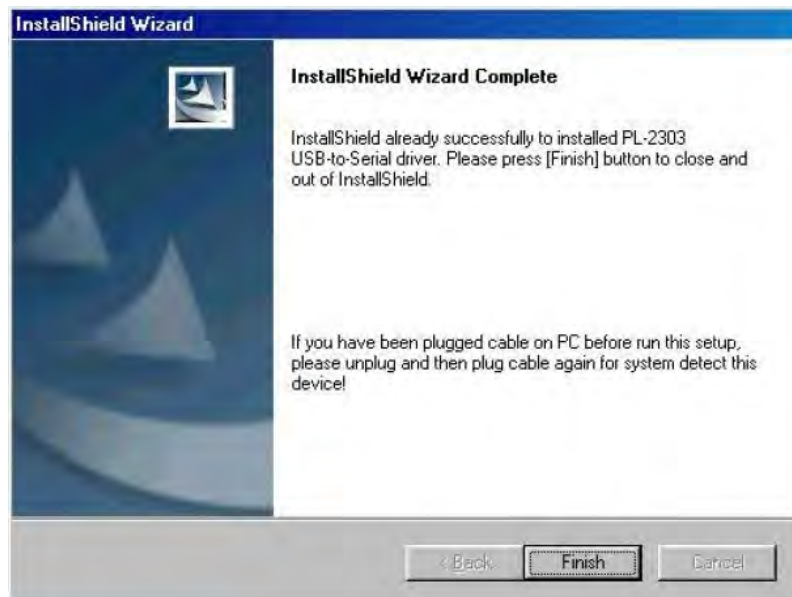

5. After the installation completes, open the Windows Control Panel from the Start menu and select “Device Manager”.

- In the Device Manger Listing, locate the “Ports (COM & LPT)” entry

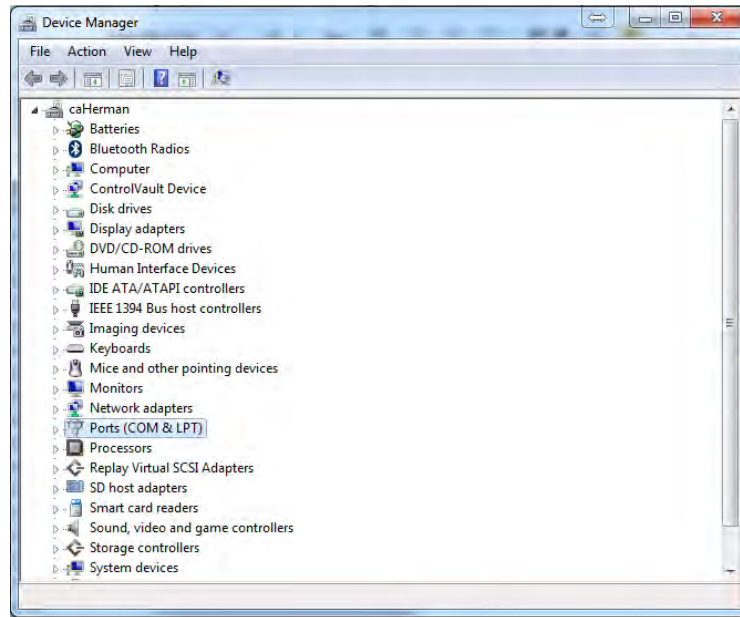

- One of the entries should show “USB to Serial Port (COMx)” with x any value higher than 2.
- Note the Com port number at which the USB device is located. Right click on this Com port and select “Properties”.
- In the Properties dialog box, select “Port Settings”.
- Select the relevant COM port and set Bit per second (baud rate) to “115200” and Flow control “Hardware”.

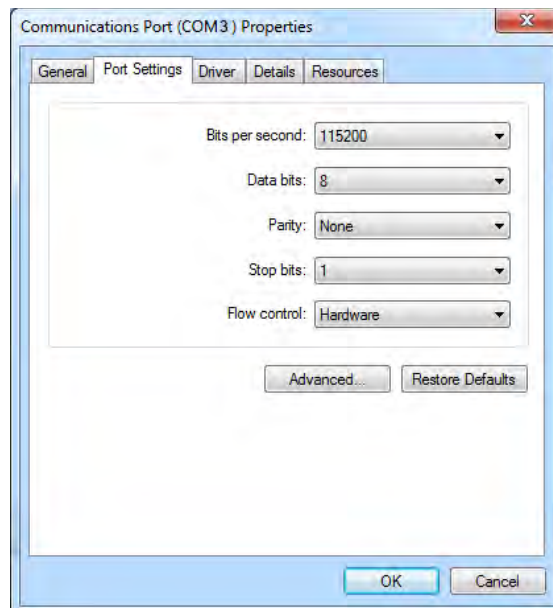

- Connect the load to the PC using a suitable USB cable. (not supplied with the load).
- You should now be able to communicate with the load through COMn.

11 LAN Driver Installation

11.1 Overview

The load may be equipped with a LAN (Ethernet) interface. To communicate with this interface, an Ethernet Manager Utility program is supplied with the LAN interface. This appendix describes the use of this utility to establish a network connection with the load under Windows.

11.2 Factory Default IP Address Setting

All Ethernet Interface cards are shipped from the factory set to a fixed, static IP address. The factory IP setting is:

192.168.16.128

This setting can be changed using the IP Scanner utility and

To access the LAN interface, your PC will have to be set to a Static IP address with the first three octets matching the LAN card setting or 192.168.16.xxx. The last octet must be different from 180 to avoid a conflict. Thus, DHCP must be turned off.

Using a direct PC to Load CAT5 LAN cable, connection to the instrument can now be made. To do so, download the IP Scanner Utility program per next section.

For instructions on how to set a static IP address under Windows 10, see Section 11.5, "Setting a static IP address on Windows 10 PC" on page 156.

11.3 Download IP Scanner Utility Program File

The LAN driver for APS loads is available from the Technical Resources page on the Adaptive Power Website. Registration may be required but access is granted via email reply immediately.

<https://tr.adaptivepower.com>

Download the APS_Loads-LAN_IPScanner.zip file as indicated in the figure below.

APS_Loads-LAN_IP

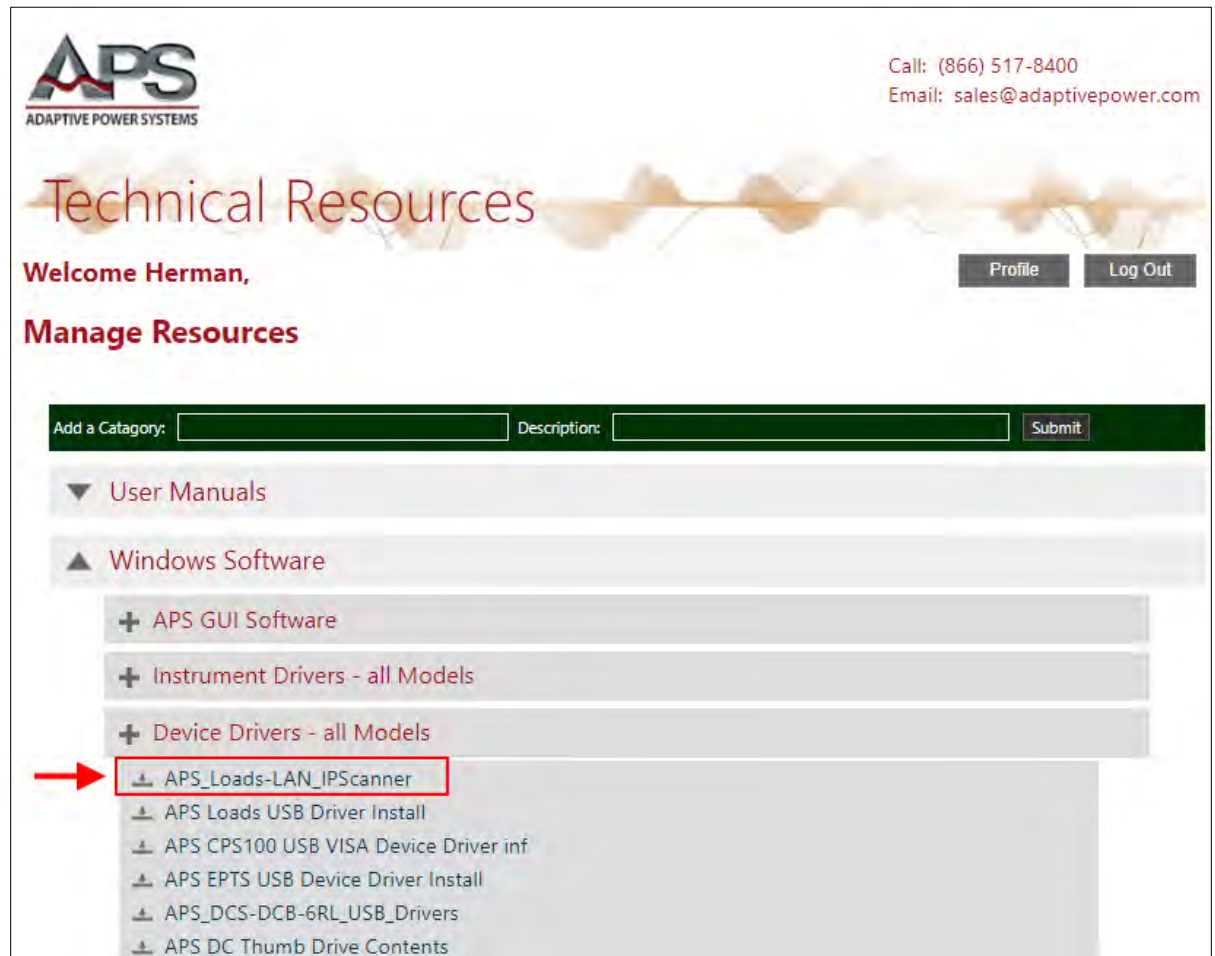

Figure 11-1: LAN IP Scanner Utility Program Download

The file name is IPScanner-**20160626.zip**. This compressed archive contains the driver installation program.

11.4 LAN Setup

To establish an Ethernet connection between a PC on your network and the load, proceed as follows:

1. Connect AC power and the network (LAN) CAT5 cable to the load.
2. Connect the other side of the network cable to an existing Ethernet network.
3. Unzip and run the APS_Loads-LAN_IPScanner utility program. It will be necessary to allow access past your Windows Firewall.

Depending on your Windows security setting, the following warning may appear. Select the Public Network option as shown below and press the "Allow access" button.

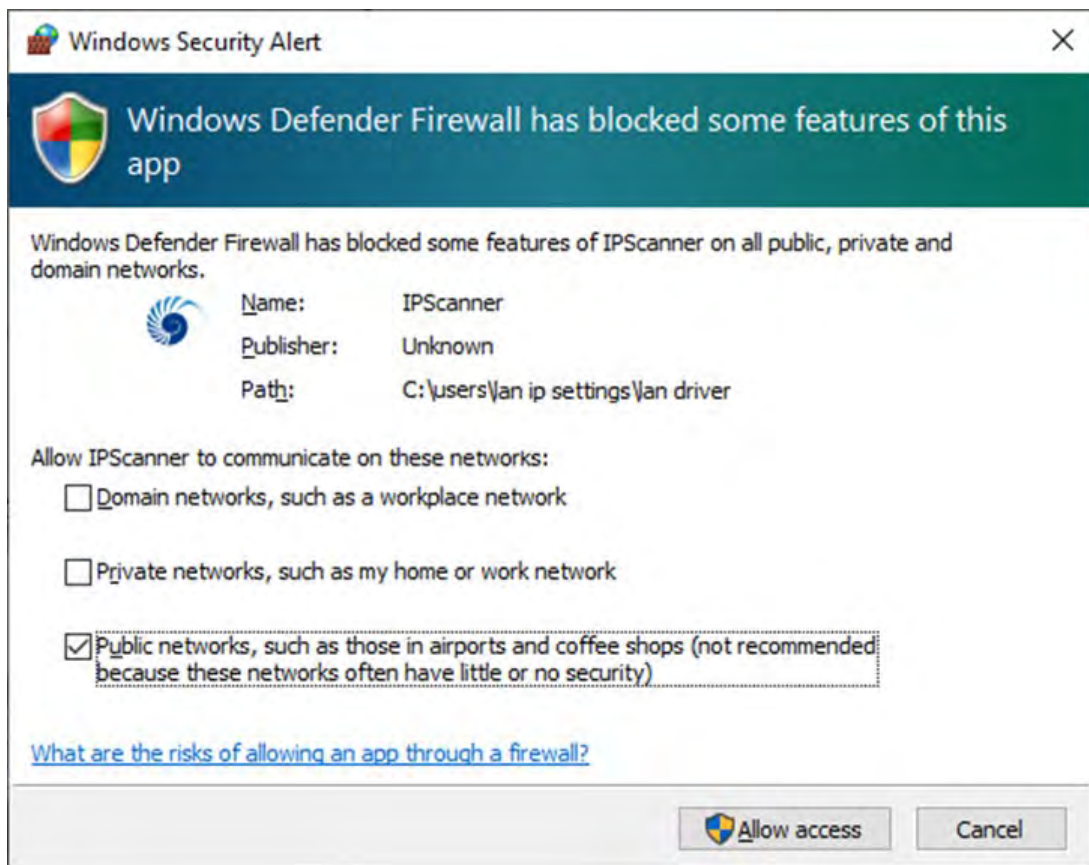

When launched, the following screen will appear. If not, please press F5 to search again, or check to see if the first step was successful or not. This screen will list the IP Address and MAC Address of any instrument found.

If you have set the IP address previously but forgot what it is, use the "IPScanner. EXE" utility list of IP addresses found to search for it.

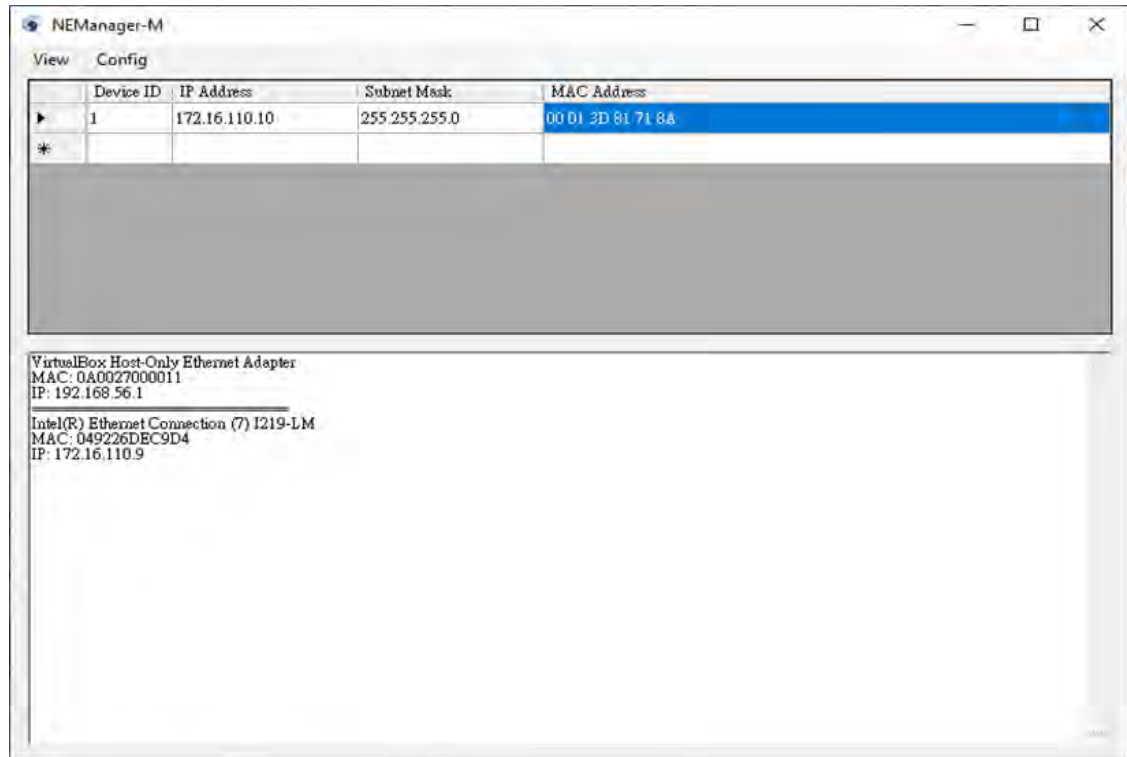

To set the IP Address and Subnet Mask, use the **Config** pull down Menu.

Select "IP Address" (Alt +Enter)

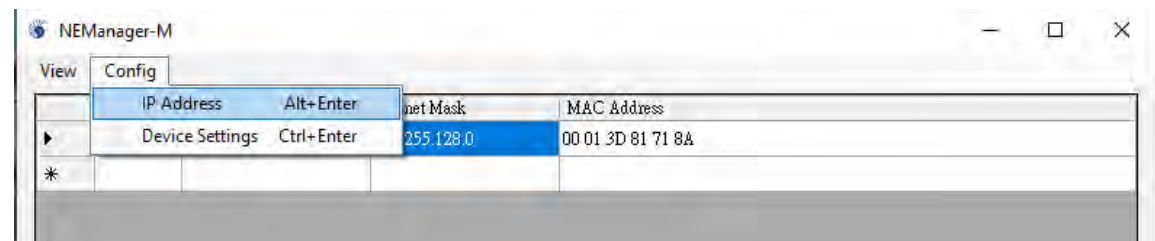

We use cookies to provide, improve, protect, and promote our services. For more information, please refer to the Privacy Policy and Privacy Policy FAQ. You can manage your personal preferences, including the "Do not sell or share my personal data when I visit this site" setting, in the Cookie Consent Tool.



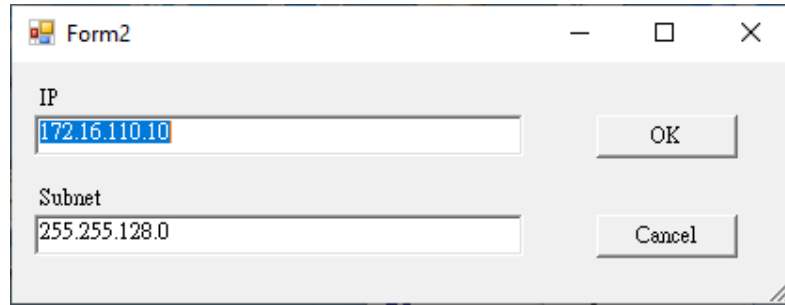

Then select “Config” → Device Settings (Ctrl + Enter) to check the connection with a web browser by entering the IP address in the browser address bar.

The default password is none. (keep it empty), then click the “Login” button to access the instruments Lan Interface Setup Page.

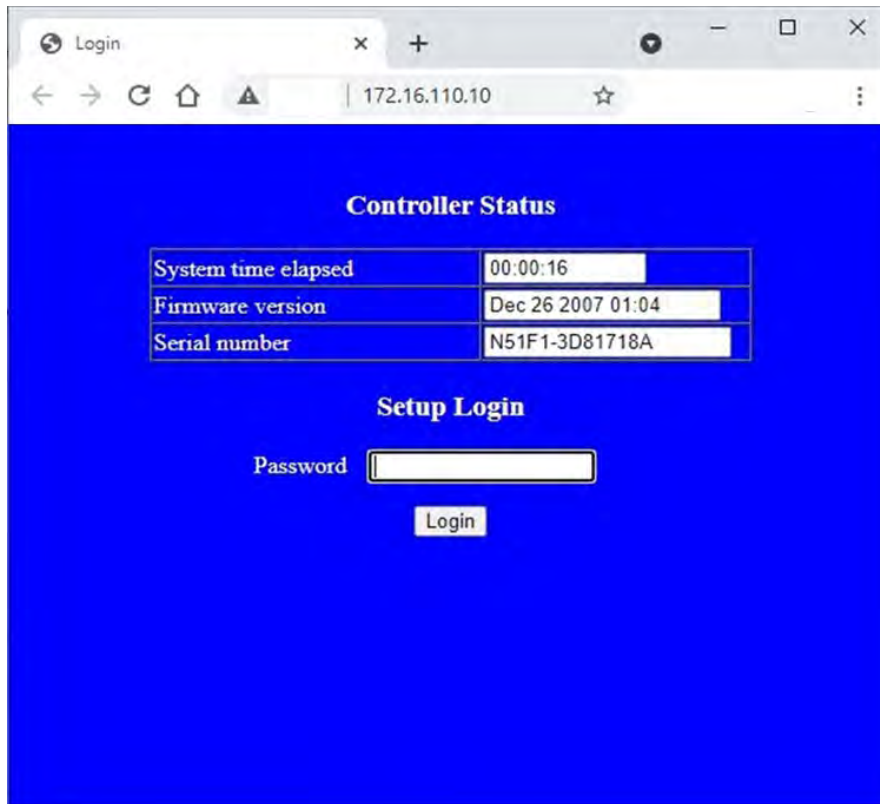

Now modify the settings as follows:

TCP socket inactive timeout (minutes) = 0
 Serial I/O setting = 115200, N, 8, 1
 Interface of serial I/O = RS 232 (RTS/CTS)
 Packet mode of serial input = Enable

Use the “**Update**” button at the bottom of the screen to save these settings.

Controller Setup	
IP address	192.168.16.128
Subnet mask	255.255.255.0
Gateway address	192.168.16.11
Network link speed	Auto
DHCP client	Disable
Socket port of HTTP setup	80
Socket port of serial I/O	4001 TCP Server
Socket port of digital I/O	5001 TCP Server
Destination IP address / socket port (TCP client and UDP)	0.0.0.0 0
Connection	Auto
TCP socket inactive timeout (minutes)	0
Serial I/O settings (baud rate, parity, data bits, stop bits)	115200 N 8 1
Interface of serial I/O	RS 232 (RTS/CTS)
Packet mode of serial input	Enable
Device ID	5
Report device ID when connected	Disable
Setup password	

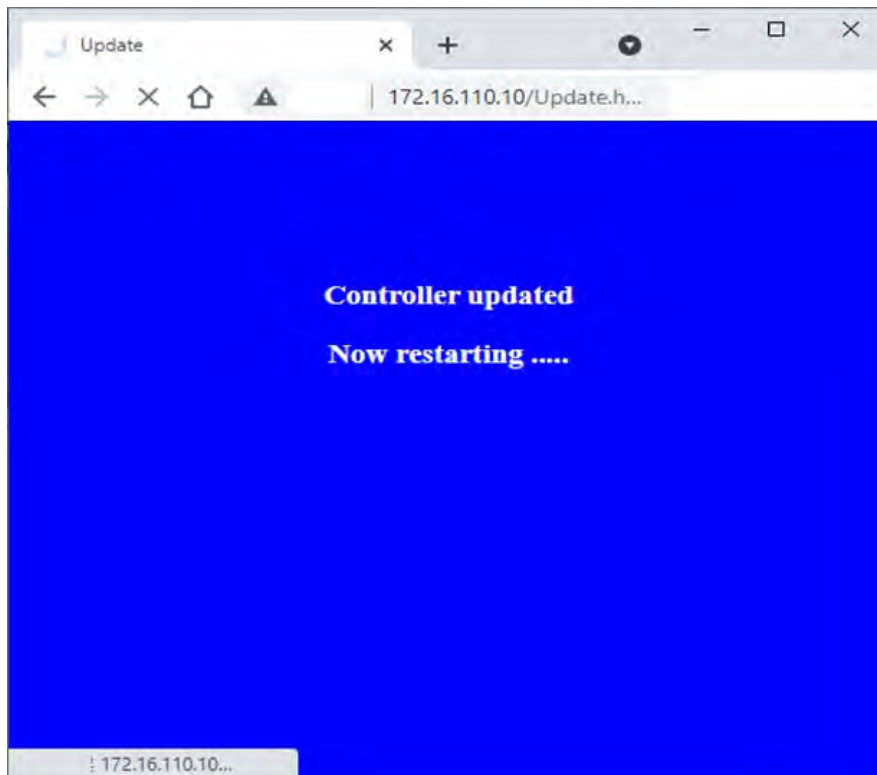

11.5 Setting up a NI-VISA Resource Connection

Open the NI-MAX utility program to set up a new VISA Resource connection for the Load.

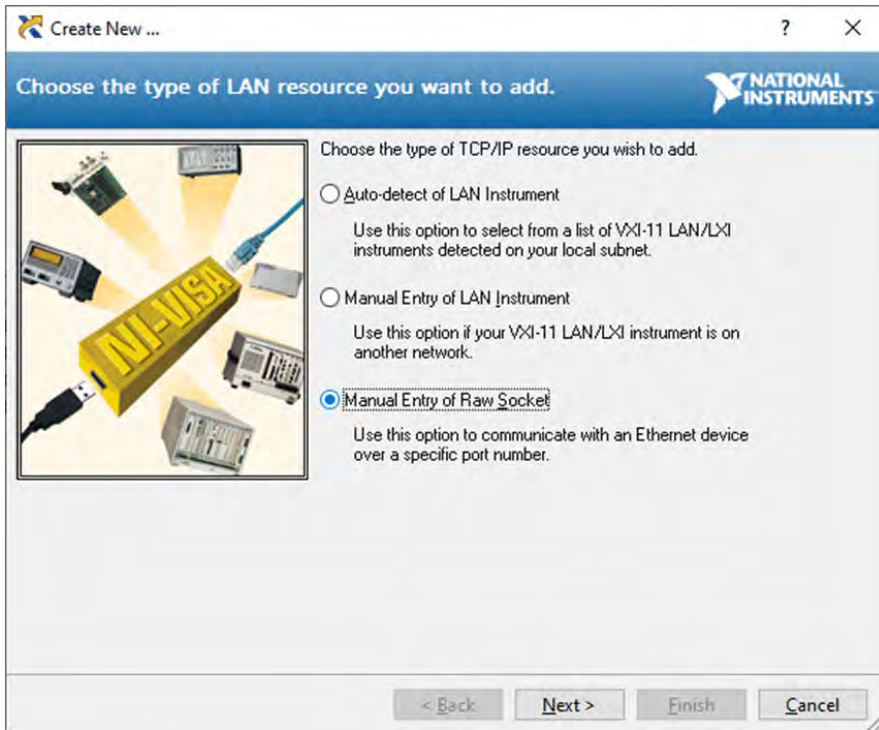
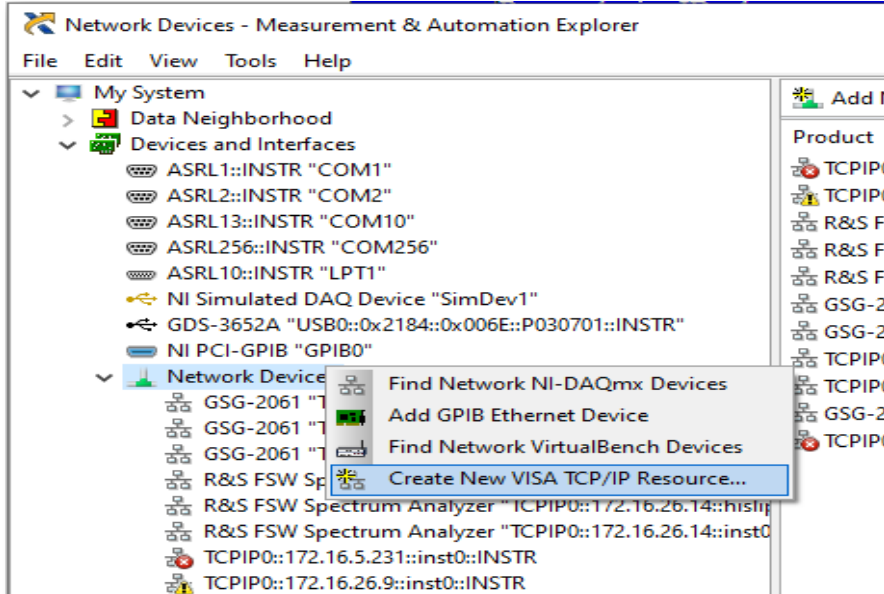

Add an Alias Name to the resource, i.e. "APS 44M04 DC Load1"

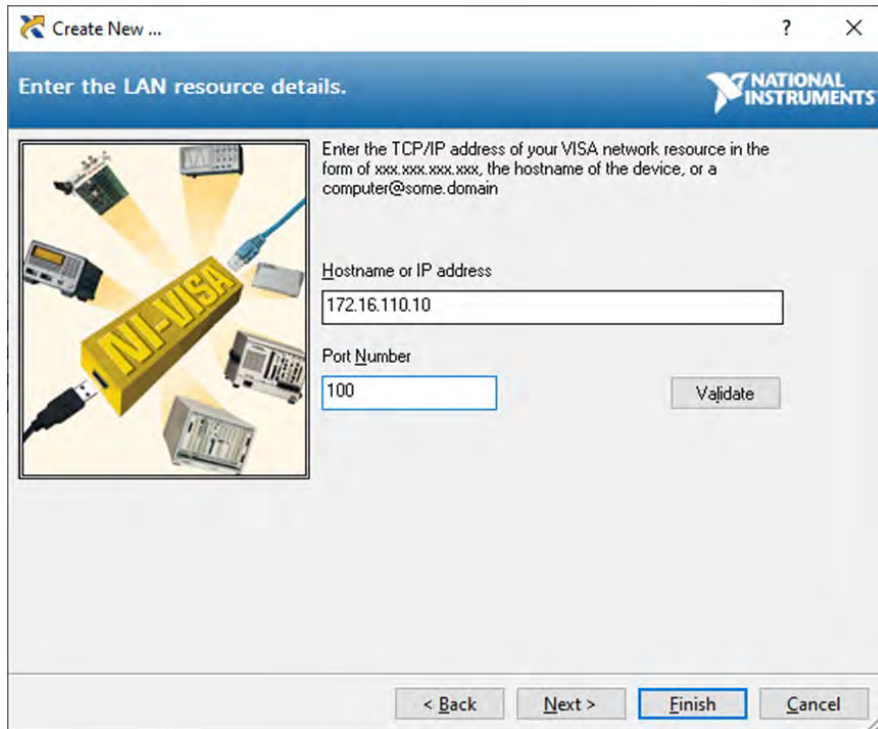
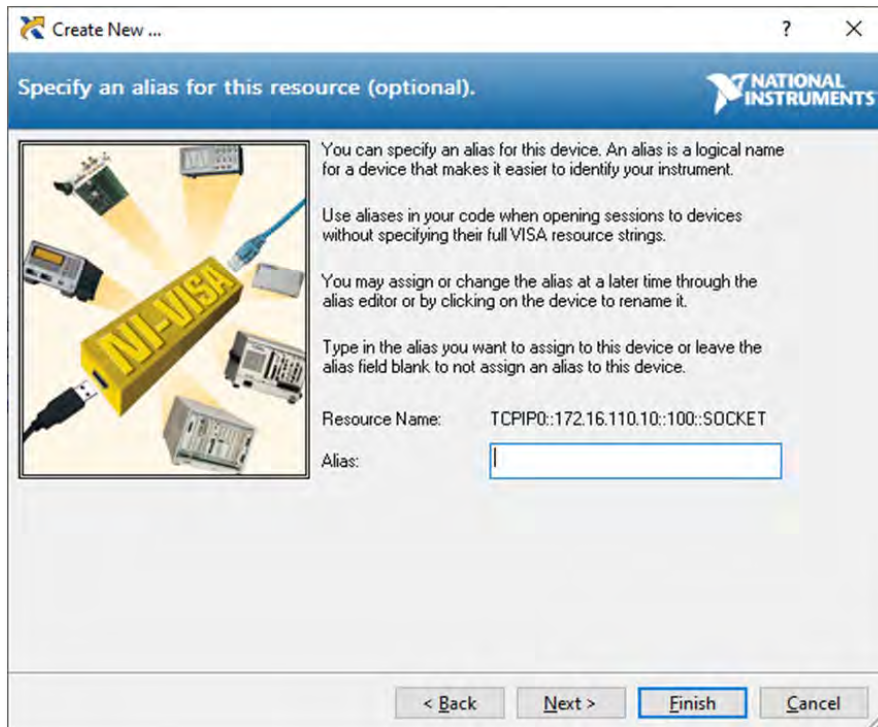

To set:

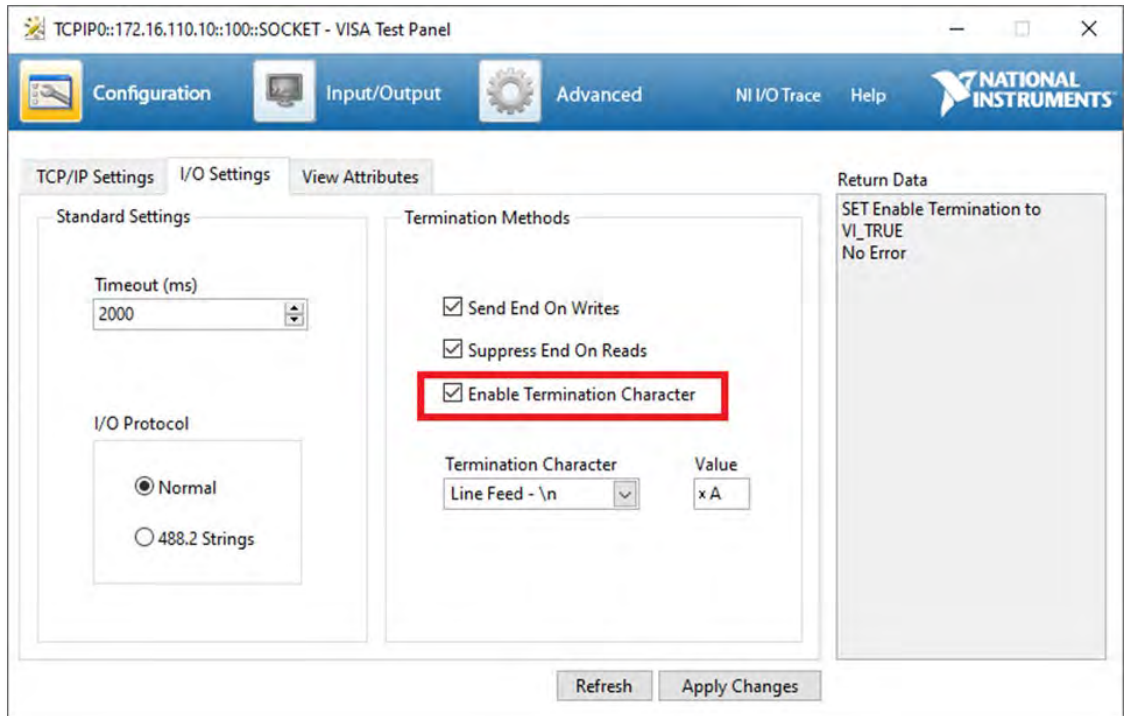
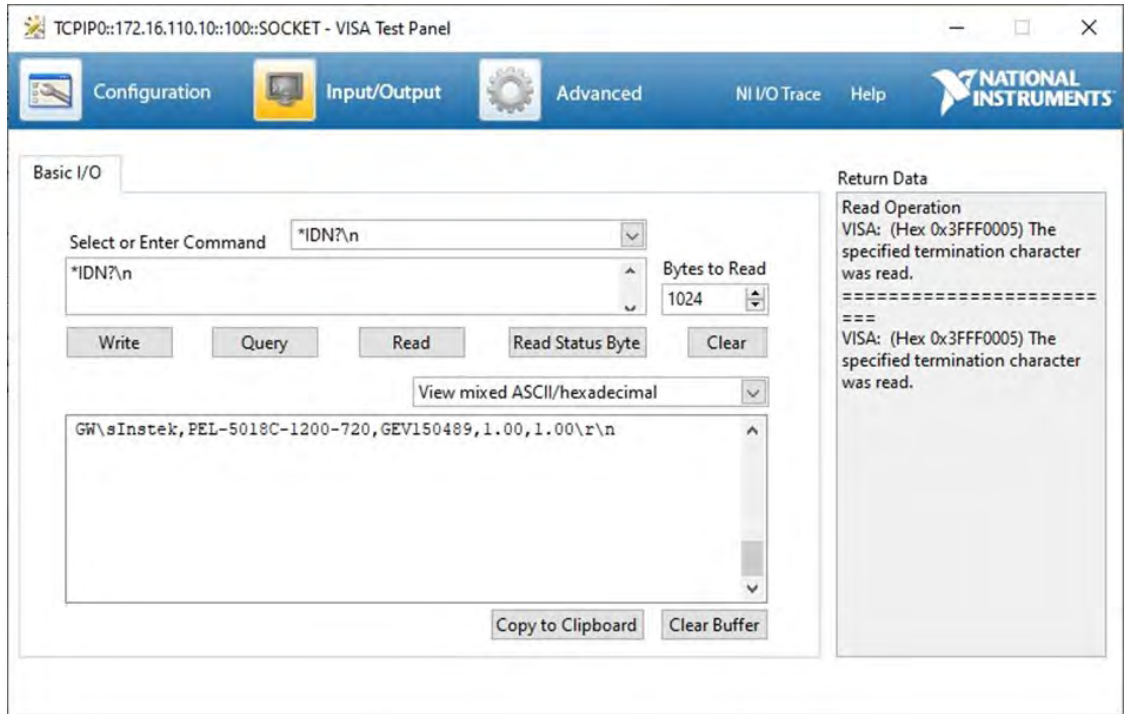

Below is an image of a CommandTableTestV14 Virtual Panel Example used to test some electronic load commands:

MEAS:VC? delay 100mS

MEAS:VOLT? delay 100ms →50ms

MEAS:CURR? delay 100ms →50ms

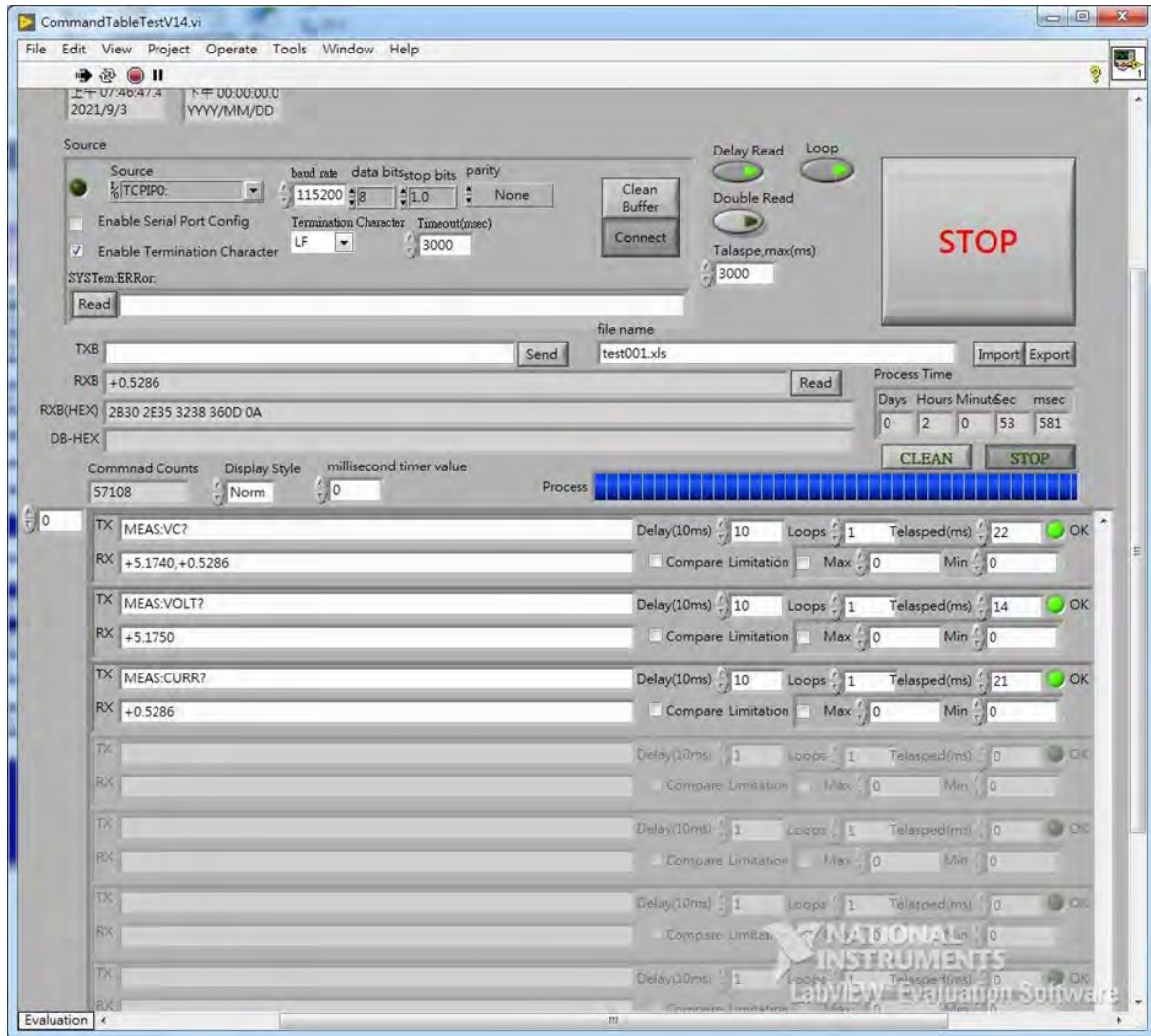

12 Calibration

12.1 Overview

All APS products ship with factory calibration. No additional calibration is required when first received.

12.2 Calibration Interval

The recommended calibration interval for these loads is one year (12 months). Routine annual calibration can be performed by most calibration labs that have Low Frequency measurement and power calibration capabilities. Alternative, the load can be returned to the manufacturer to obtain a factory calibration.

12.3 Calibration Coefficients

All calibration is performed through software. No manual internal adjustments have to be made as part of routine calibration.

Calibration coefficients for the following parameters and functions are stored in non-volatile memory:

Parameters	Coefficients Stored
Load Current	All modes, AC & DC, Offset and Gain, High Range & Low Range
Resistance	All modes, AC & DC, Offset and Gain, High Range & Low Range
Voltage Measurement	AC&DC, Offset and Gain
Current Measurement	AC&DC, Offset and Gain
Power Measurement	AC&DC, Offset and Gain

12.4 Calibration Procedures

Certified calibration labs may request a copy of the calibration manual for the relevant load model by contacting the nearest Adaptive Power Systems company location. Refer to Section 1, "Contact Information".

13 CE MARK Declaration of Conformity

Directive: 2004/108/EC

Product Name 3C Series AC & DC Electronic Loads, all models.

Serial Number _____

The manufacturer hereby declares that the products are in conformity with the following standards or other normative documents:

SAFETY:

Standard applied IEC 61010-1:2001

EMC:

Standard applied EN 61326-1:2006

Reference Basic Standards:

EMISSIONS:

CISPR11: 2003+A1: 2004+A2: 2006
EN 61000-3-2: 2006
EN 61000-3-3: 2008

IMMUNITY:

IEC 61000-4-2: 2008
IEC 61000-4-3: 2008
IEC 61000-4-4: 2004 +Corr.1: 2006 +Corr.2: 2007
IEC 61000-4-5: 2005
IEC 61000-4-6: 2003+A1: 2004+A2: 2006
IEC 61000-4-8: 2001
IEC 61000-4-11: 2004

Supplemental Information:

When and Where Issued: March 28, 2018
Irvine, California, USA

Authorized Signatory Loc Tran
Quality Assurance Inspector
Adaptive Power Systems

Responsible Person Joe Abranko
Adaptive Power Systems
17711 Fitch
Irvine, California, 92649, USA



Mark of Compliance

14 RoHS Material Content Declaration

Adaptive Power Systems declares under its own responsibility that the products listed under **Product List** meet the European Union’s Restriction on Hazardous Substances Directive RoHS 2.0 (2011/65/EU, 2015/863/EU and REACH 1907/2006.EC requirements. The hazardous substances and threshold values are shown in the following table. All the product(s) are fully compliant with the EU RoHS Directive.

Please visit the website for the latest information about the SVHC substances published by ECHA

<https://echa.europa.eu/candidate-list-table>

Substance Name	Threshold Value	Directive Requirements
Lead (Pb)	< 0.1% (1000 ppm)	2011/65/EU
Cadmium (Cd)	< 0.01% (100 ppm)	
Mercury (Hg)	< 0.1% (1000 ppm)	
Hexavalent Chromium (Cr6+)	< 0.1% (1000 ppm)	
Polybrominated biphenyls (PBBs)	< 0.1% (1000 ppm)	
Polybrominated diphenyl ethers (PBDEs)	< 0.1% (1000 ppm)	
Bis (2-ethylhexyl) phthalate (DEHP)	< 0.1% (1000 ppm)	2015/863/EU
Butyl benzyl phthalate (BBP)	< 0.1% (1000 ppm)	
Dibutyl phthalate (DBP)	< 0.1% (1000 ppm)	
Diisobutyl phthalate (DIBP)	< 0.1% (1000 ppm)	

Manufacturer/Importer

Company Name: Adaptive Power Systems

Company Address: 17711 Mitchell North, Irvine, CA 92614, USA

Product List:

AC Loads. 3C018-18, 3C028-18-EV, 3C028-28, 3C038-28-EV, 3C038-38, 3C056-56, 3C075-75, 3C0112-112, 3C150-112, 3C188-112, 3C225-112

Person is responsible for marking this declaration:

Date: 2021/08/25

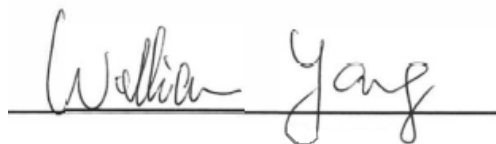

William Yang

Index

A

AC Input	71
Accessories	48, 69

C

Configuration	137, 140
Connections	108
Constant Current	14, 15, 47
Constant Power	14, 16
Constant Resistance.....	14, 15, 112
Constant Voltage	14, 15
Contact	9, 72, 163
Contents	3

D

Displays.....	80
---------------	----

F

Features	47, 104
Frequency	163
Fuse.....	70
Fuse Test.....	14

G

Go / NoGo.....	130
Go/NoGo.....	47

I

Inrush current mode.....	42
Installation	10, 69, 151, 153

L

LAN VISA Resource	161
-------------------------	-----

P

Power factor.....	47
Programming.....	110, 112
Protection.....	54, 104, 105
PV System Efficiency	14

S

Size	107
Specifications	50
State	124
Synchronization.....	88

T

Terminals.....	106, 108
Turn on.....	72

U

UPS Backup Test.....	14
UPS Efficiency.....	14

V

Voltage sense	108
---------------------	-----

W

Warranty	10
----------------	----





ADAPTIVE Power Systems

Worldwide Supplier of Power Equipment

Copyright © 2023, Adaptive Power Systems, Inc. (APS) • All Rights Reserved • No reproduction without written authorization from APS.