

Large Scale Use of Solid State AC Power Sources for Automated Transformer Testing



17692 Fitch
Irvine, CA 92614

Phone (USA): 800-854-2433
Phone (Int'l): 949-251-1800

Mitchel Orr – Pacific Power Source, Inc.
Alvin Kopp – High Voltage Test Engineering

INTRODUCTION

Major distribution transformer manufacturers test thousands of both large and small transformers at world wide locations every week. Traditionally, variable voltage plant power feeds and/or fixed frequency, variable voltage, motor generator sets (MGs) have been used in this application. Advances in Solid State Power Electronics over the last decade has allowed these traditional variable voltage plant power feeds to be replaced with solid state AC power sources. The solid state AC sources have both economic and technical advantages over variable voltage plant power feeds and motor generator sets. This paper demonstrates that by using programmable AC Power Sources in place of tap changing transformers and rotating equipment, advanced levels of control, flexibility, and facility design are obtained. The benefits enjoyed by these new test methods are flexibility and cost savings that translate directly into increased test efficiencies and profits.

OVERVIEW

Today, Solid State AC power sources are capable of testing small and large power transformers. These power sources are available in a multitude of kVA ranges, able to change frequency and deliver full current across a wide voltage range. The flexibility, power capacity and remote computer control capability of these supplies eliminates the need for breaker controlled variable voltage motor generator sets or breaker controlled variable voltage plant power feeds to supply voltage and current to the equipment under test. All power test equipment including applied test sets, induced step up transformers, core loss and load loss step up transformers, as well as any auxiliary power requirements such as LTC's or fans can all be supplied from the same power source.



17692 Fitch
Irvine, CA 92614

Solid State AC Power Sources provide new technical and speed advantages for test floors. The power sources are not susceptible to load induced damage caused by transformer failures on the test floor. In many applications, the power sources can be “hardened” to withstand the ground transients generated during high voltage Lightning Impulse tests. Additionally, these power sources have the advantage of thermal/electronic tripping that limit the amount of short circuit current that they can deliver in the event of a test failure. Limiting the amount of short circuit current makes core loss failures less catastrophic and eliminates the need for high voltage/high current breaker protection on the test floor.

The power sources may be paralleled to increase total kVA during the initial facility design or expanded later in the field. This feature offers the test floor designer the flexibility of sizing the floor for existing power demands, while facilitating the ability to increase future test capacity. When the power sources are used in conjunction with a fully compensating capacitor rack, there is no practical limit to the size of power transformer that can be tested since the solid state power sources will only be supplying real kW losses.

CONFIGURATION

With the power level established, the actual test plan may now be considered. A standard test floor block diagram is presented in Figure 1.

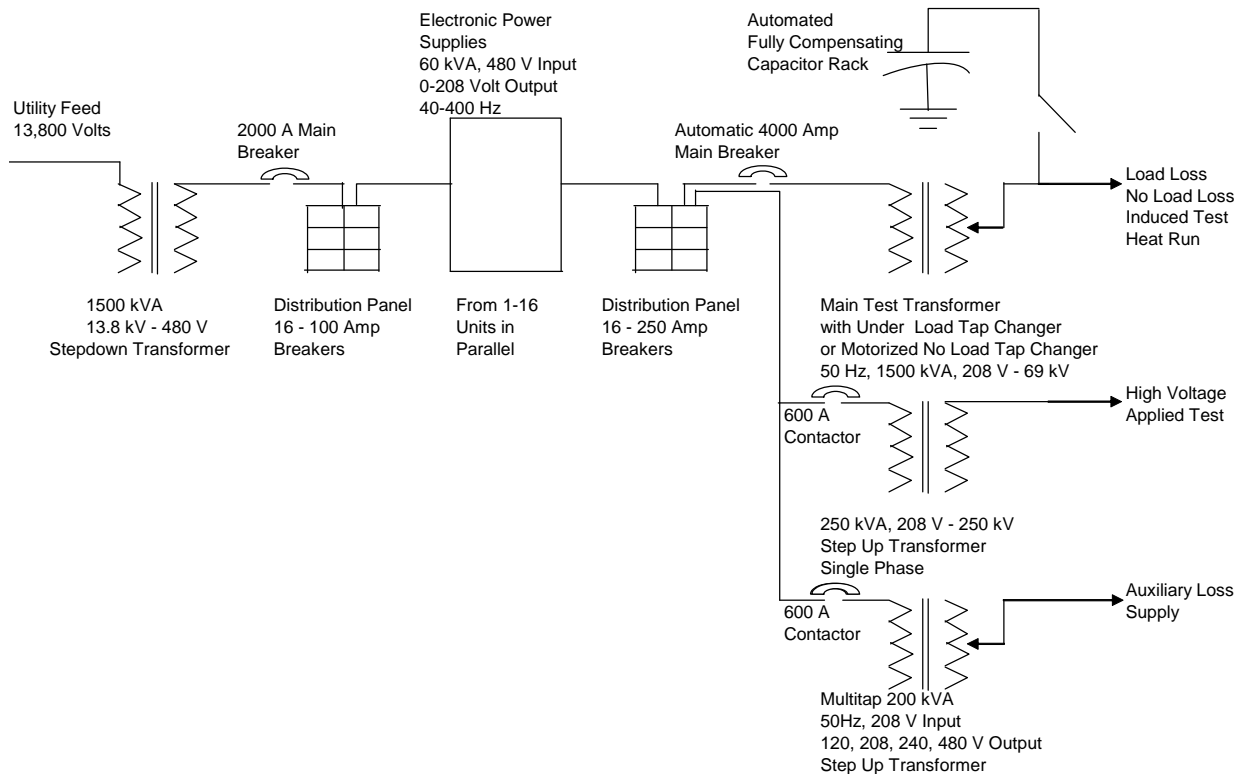

Figure 1 – Typical Test Floor

The diagram demonstrates how a 13,800 Volt three phase plant feed powers the whole test floor thru a 1500 kVA step down transformer connected to the outside utility feed. The output of this step-down transformer is 480 Volt. The 480 Volt then runs thru a 2000 Ampere main breaker in a breaker panel with sixteen 100 Ampere breakers feeding the required number of AC Power Sources.

The 0-208V output of the AC Source is then fed to a distribution panel with sixteen, 250 Ampere breakers and a 4000 Ampere main automatic breaker. The output of the distribution panel is then routed through three load contactors that power the main step transformer, applied test set, and auxiliary loss transformer. The fully compensating capacitor rack is directly connected to the transformer under test. This test floor system minimizes size of the main test floor transformer and its associated losses making full use of the versatility of the AC power source to meet all of the testing requirements.



62.5kVA, 40-400Hz
AC Power Source

TEST METHODS

Using a solid state power source allows variable frequency operation. 50Hz or 60 Hz core loss tests may be performed from the same AC Source by sending a computer command to change frequencies. The transition from core loss to induced voltage testing now only requires a computer command to change frequencies from the core loss frequency to the induced test frequency and then ramp the voltage up. The advantage of using a variable frequency power supply for induced testing is that it allows the operator or computer program to find the minimum excitation current by varying the frequency. This is important because all transformers become capacitive loads at some frequency. The solid state power source can be programmed to increase the frequency starting at the required multiple of the core loss frequency to reach the induced test frequency which draws the lowest current. (Ex: If a LV:480 V, 500 kVA transformer needed to have an induced test which per ANSI standards is approximately 2x rated voltage then the solid state power source would change from 60 Hz to 120 Hz and then ramp the frequency up from 120 Hz until the excitation current minimum was found). As test frequency is increased the excitation current will go down until the capacitive current of the transformer becomes greater than the magnetizing excitation current. This new control method eliminates the dangers of an over-voltage condition on the UUT experienced when the capacitive transformer load would self-excite a motor generator. Only the variable frequency solid state power supplies allow an operator to perform the testing in this manner.

Due to their output capacitive filtering, AC Power Sources generate less than 5 pC of Partial Discharge (PD) so they will not interfere with the PD and Radio Interference Voltage(RIV) testing of transformers. Motor Generator sets often require output PD/RIV filters to be used so that the PD/RIV measurements made at the transformer under test do not pick up the generator brush contact PD noise. All of the frequency and voltage

Large Scale Use of Solid State AC Power Sources for Automated Transformer Testing

changes required to meet the ANSI/IEEE or other customer specified test requirements are programmed on a host computer. This process eliminates the need for operator intervention and significantly decreases test time.

TEST ADVANTAGES

Traditionally test floors have relied on using several motor generator sets or a combination of sliding contact and/or under load tap changing transformers and motor generator sets as variable voltage and frequency sources for a transformer test floor. These sources of power would normally be used to vary the input voltage to an applied test step up transformer, load loss step up transformer and/or core loss step up transformer. There are several drawbacks of to each type of variable voltage or frequency supply:

- 1) Motor generator sets are expensive and can only deliver voltage at only one frequency. Motor generators require separate excitation systems. If the separate excitation system is another small motor generator set then the main motor generator set output will not have good voltage stability.(IE: The hunt and seek phenomena. This is a complex interaction between the MG set and transformer load that sets up a voltage/current oscillation, at a lower frequency than the 60 Hz output of the MG set, which makes the generator voltage move up and down without operator intervention) Even though most modern separate excitation systems are now solid state and the voltage stability is fairly good, Motor generator sets are still large, noisy and require maintenance of the bearings, input air filter and brushes. When these systems are placed on a test floor it is difficult

to hear any spoken words so most are in soundproof rooms. Additionally, MG sets generate a significant amount of Partial Discharge. This Partial Discharge from the generator commutator brushes makes it difficult to perform RIV/PD tests without in-line noise filters or large impedances between the motor generator set and transformer winding under test.

These motor generator sets require large starters and breakers for operation and must be given time to spin up or spin down. An induced motor generator set is also prone to self-excitation. The self-excitation phenomenon can cause an over-voltage in the generator and transformer under test. I have witnessed a 1000 kVA, 4160 volt generator failure due to a self-excitation event while testing a 300 MVA power transformers.

- 2) Under load regulators come in several types. These regulators can be the toroidal variac type for small loads such as an applied test set. These regulators can be a sliding or rolling contact design where the moving contact runs up and down the face of the coil. The regulator can be an under load tap changing(ULTC) transformer. All of these regulators have a defined limit to the smallest voltage step they can move which is the Volts/Turn of the coil(ie: typically 10-20 Volts). AC Power sources can supply voltages with much smaller steps(ie: 0.1 Volts) because there is no physical Volts/Turn lower limit. The ULTC regulators cannot supply voltage at different frequencies unless a motor generator is connected to them to supply them with different frequencies and the core of the regulator is designed for the different frequencies. These regulators require some mechanical

maintenance of the moving contacts.. Typically for ULTC regulators this means annual or semi-annual inspections. For the sliding contact transformers, inspections should occur more frequently. Regulators require breakers on the input side to minimize damage should a fault occur on the output side of the transformer. Typically the impedance of a regulating transformer is designed to be low to minimize the voltage drop across the regulator under full load. This means that the regulator is susceptible to damage if not protected by a correctly sized breaker.

The sliding contact and toroidal regulators can generate a significant amount of Partial Discharge due to their moving brushes which can interfere with PD/RIV testing. Regulators also take time to run up and down their voltage range whereas solid state AC Power sources can reach a given voltage in a matter of seconds. This allows a user to check voltages and currents quickly while ramping up and turn the voltage off instantly once a test is complete. This is very important when performing load loss so that the resistive heating caused by the test does not throw off the losses measured during the test,

When using plant power feeds, sliding contact or under load tap changing transformers a manufacturer is required to add high voltage/high current capacity breakers to the test floor. The reason for this is that motor generator sets and plant power feeds can supply tremendous amounts of fault current should a transformer under test ever fail. Test floor failures of transformers are relatively frequent occurrences. A distribution transformer plant may have one or more per day while a large power transformer plant may experience one every month. These high current breakers are expensive and the

inherently dangerous in a test floor environment. The reason these breakers are dangerous is that they are designed for utility operation and not test floor usage. A typical test floor may open and close a circuit breaker ten or more times per day. In a utility environment, this same breaker may only be used several times per year. I have personally witnessed external flashovers and explosions due to mechanical wear and dirt buildup on vacuum, air and oil breakers. For this and other reasons, most test floors require more than one of these breakers in series in case one fails. These breakers require maintenance and inspection every few thousand operations. Solid state AC power sources do not require these breakers and can be fed from and feed out of standard breaker panels. The breakers in these panels do not need to be operated because the power supply can be turned on and off with a computer command and only serve as protection in the event of a wiring short.

The only requirement for the solid state AC power source is a set of contactors so that the power supply output can be switched to power up the correct test equipment.



Figure 3. Remote Control for Electronic Power Supply



17692 Fitch
Irvine, CA 92614

Test floors can now be automated because the operator has full control of the test voltages and frequency thru a computer and the electronic power supply remote control unit shown in Figure 3. Therefore, standard tests such as load loss, core loss, induced voltage, applied voltage, heat run and soak tests (extended core loss tests) can be fully automated requiring no operator intervention during testing. The operator has only to connect the test leads and the computer controlled solid state AC power sources can ramp up check voltages and currents against target values and query measuring equipment to take final measurements. These values can then be dumped to test reports and sent with the transformers to customers. Without the ability to accurately and completely control the power supplies, the operator would have to manually ensure phase to phase voltage and current balance. The individual phases, phase angles, voltage and frequency can be remotely controlled on the solid state AC power sources. In the future, all test floors whether they test motors, transformers, breakers or other power equipment will use solid state AC power sources to automate standard load loss, core loss, applied, induced and heat run tests. This saves testing time and eliminates the need for a skilled operator to achieve repeatable results.